

ILLUSTRATED PARTS LIST
PIEZAS DE REPUESTO
LE RÉPERTOIRE DES
PIÈCES ILLUSTRÉES

A CYLINDER/CILINDRO/CYLINDRE

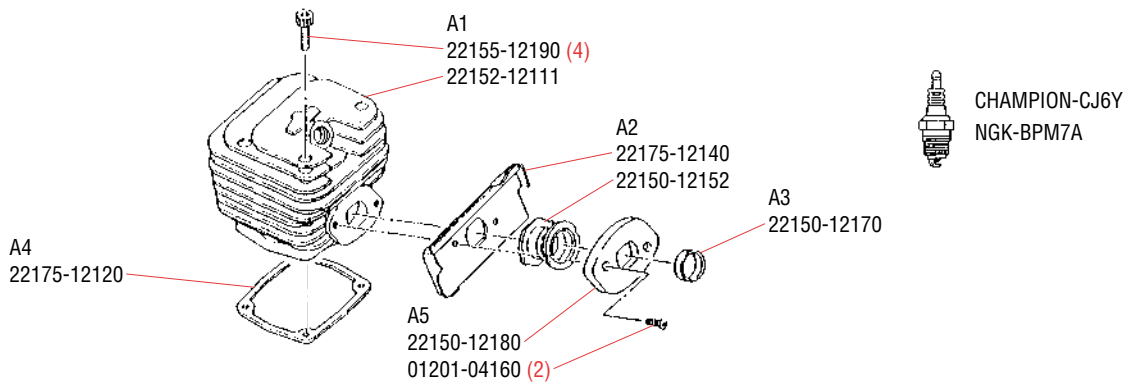

B MUFFLER/SILENCIADOR/SILENCIEUX

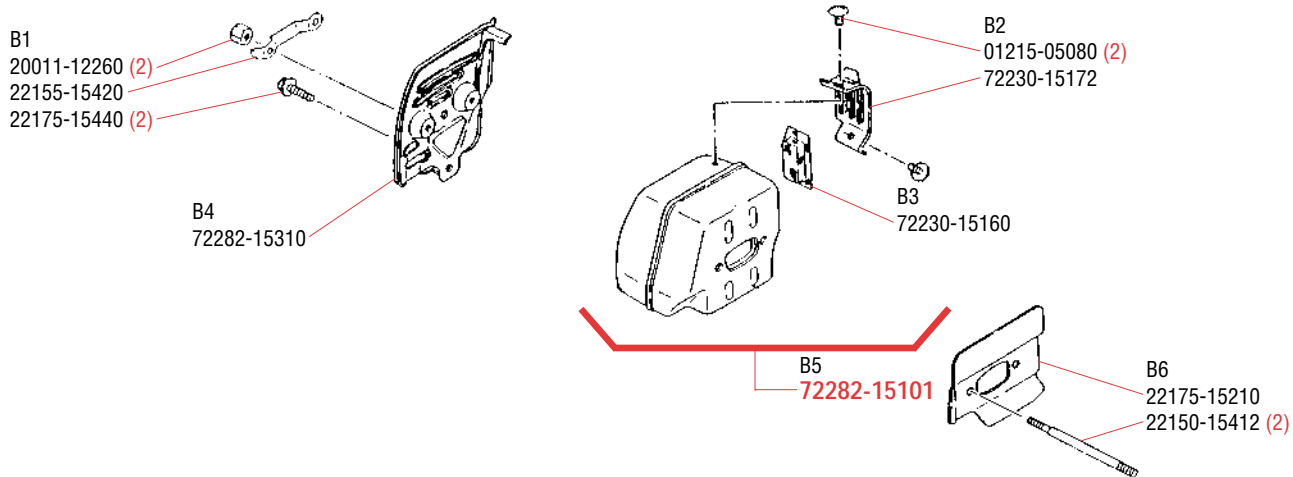

C CRANKCASE/TAPA/CARTER DE MANIVELLE

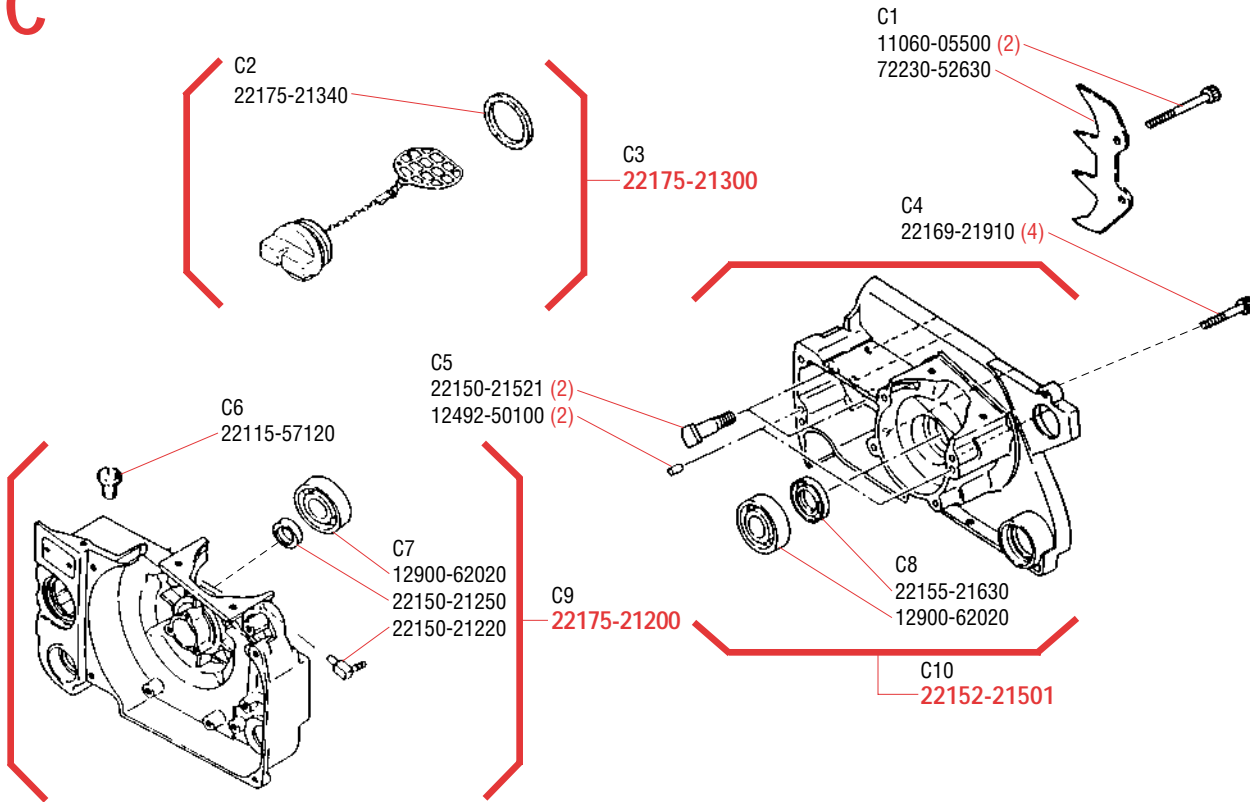

D PISTON, CRANKSHAFT/CIGUEÑAL/VILEBREQUIN

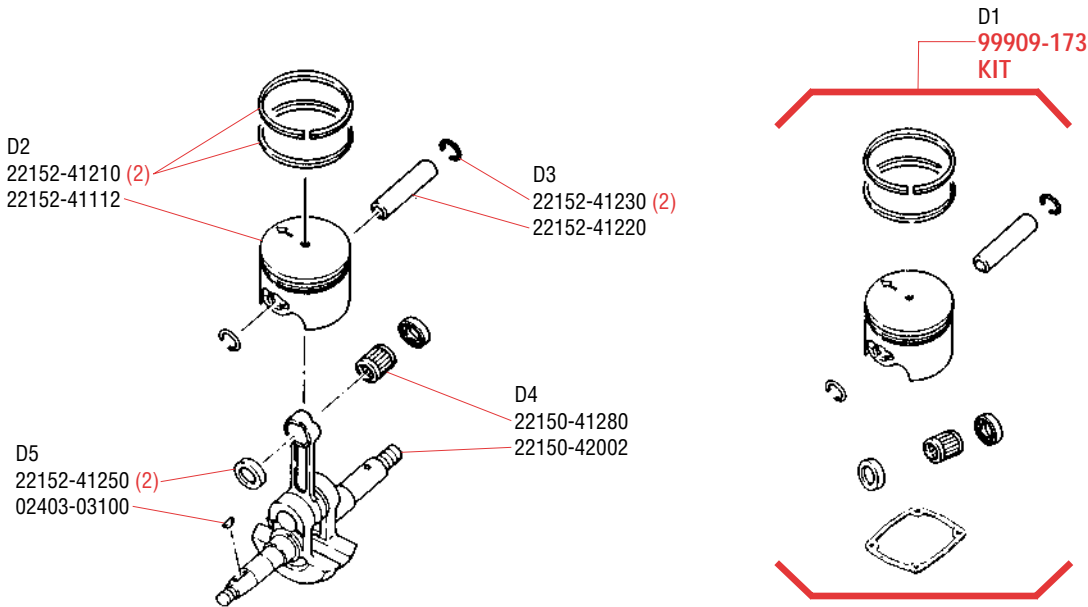

Legend — Leyenda — Légende

- () — Quantities Required
- — Option
- ★ — 3/8" - 7
- ▼ — 3/8" - 8
- — .325" - 9



Shindaiwa Inc.

P.O. Box 1090, Tualatin, OR 97062
 11975 S.W. Herman Rd., Tualatin, OR 97062

E CLUTCH SHOE/ZAPATA DEL EMBRAGUE/SABOT D'EMBRAYAGE

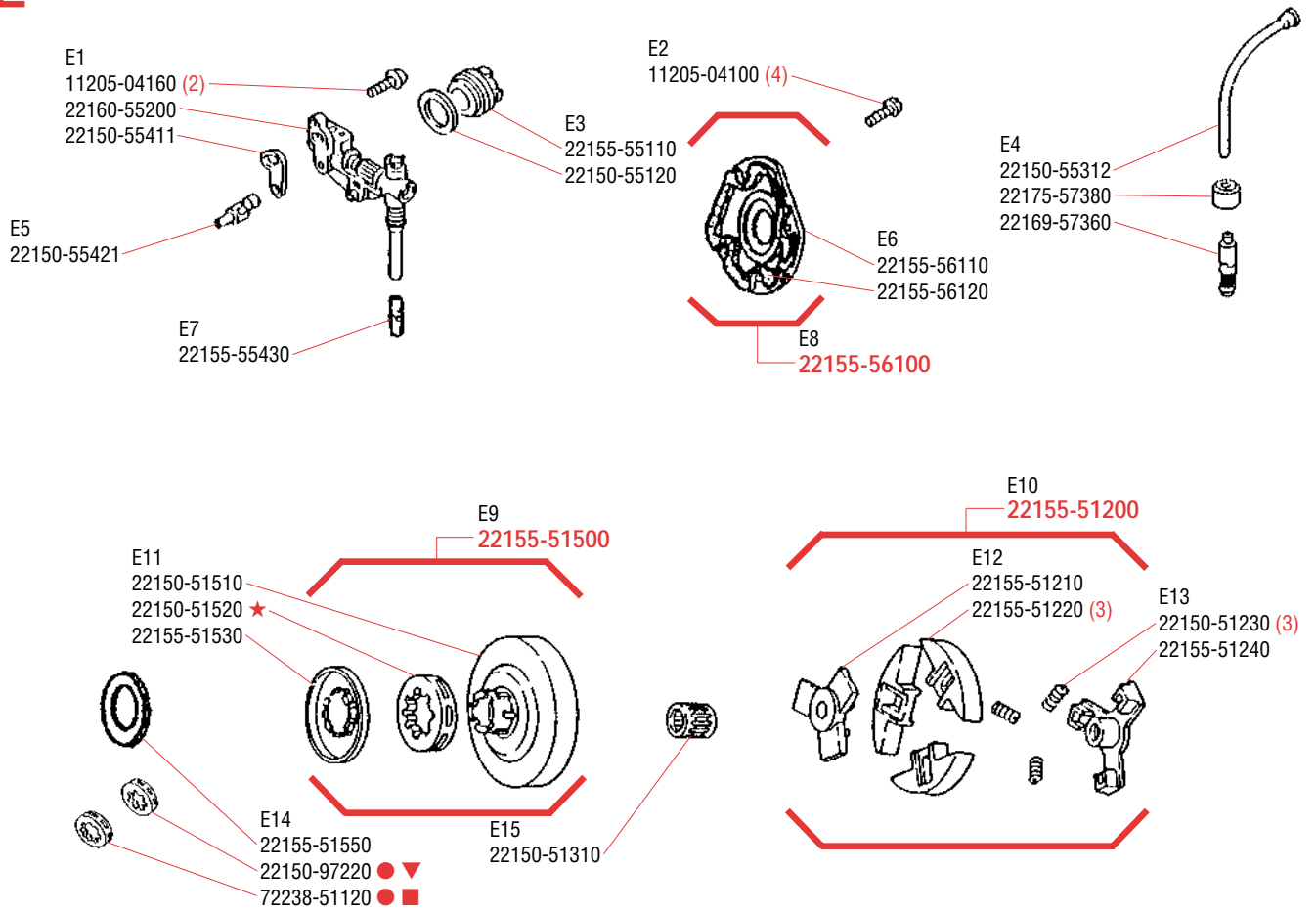

F CLUTCH COVER/TAPA DEL EMBRAGUE/COUVERCLE D'EMBRAYAGE

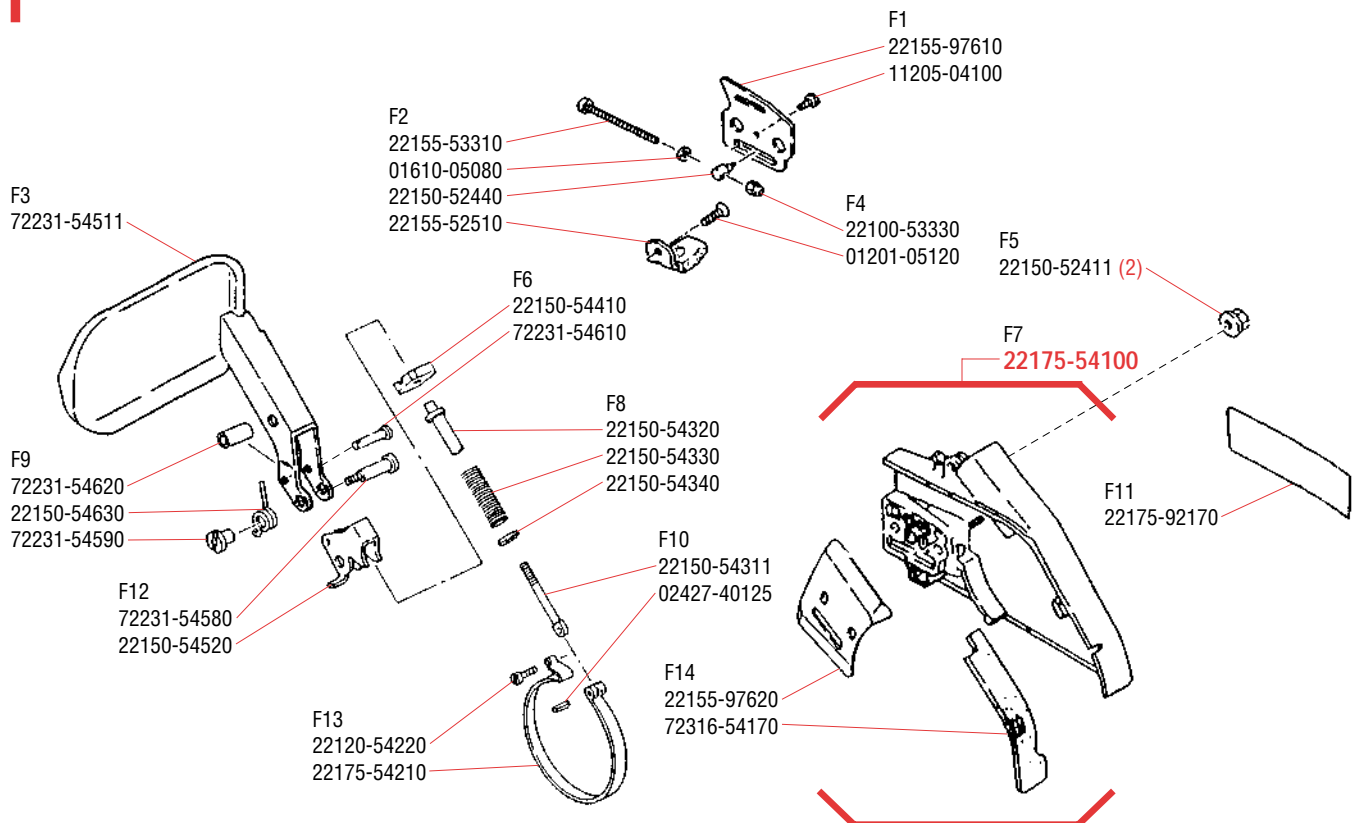

G FLYWHEEL/VOLANTE/ROTOR

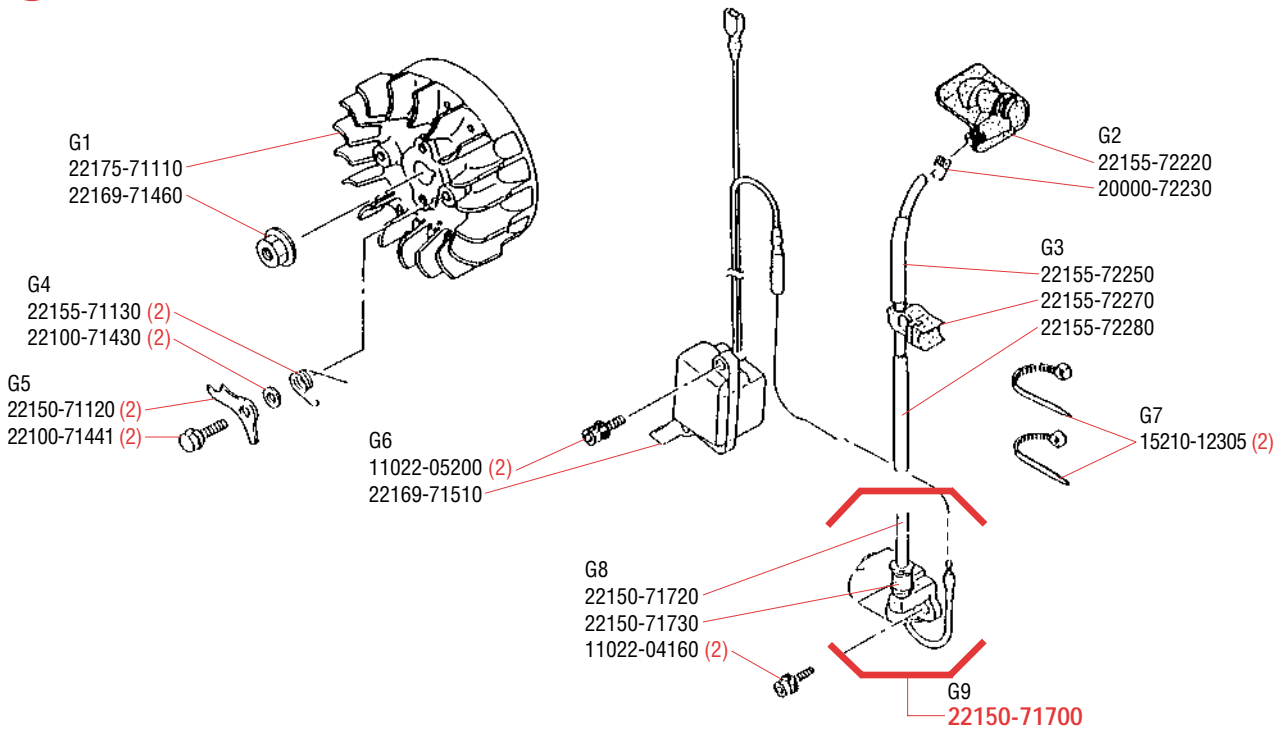

H RECOIL STARTER/ARRANCADOR/DÉMARREUR

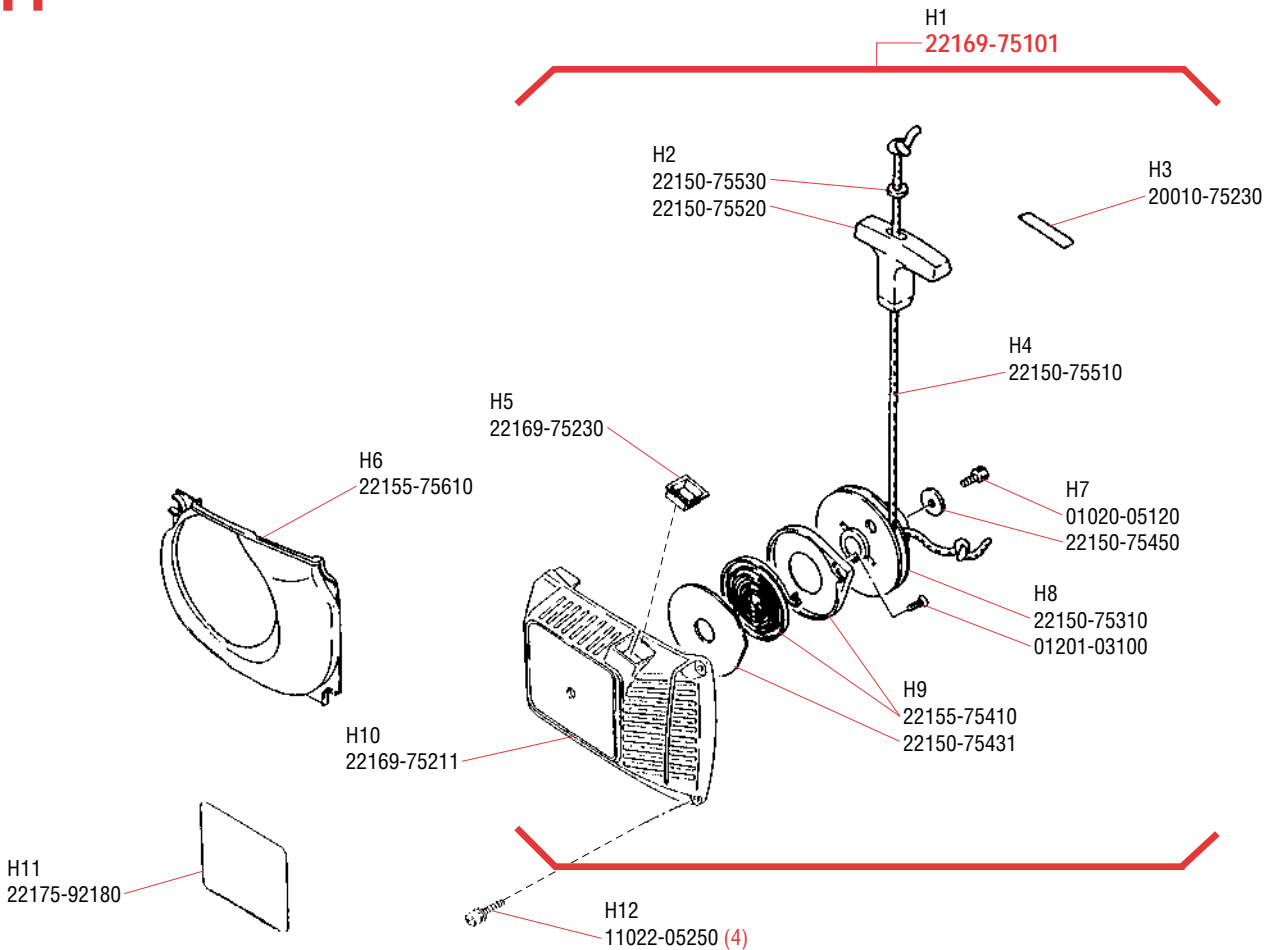

J FRONT HANDLE/MANGO DELANTERO/POIGNÉE AVANT

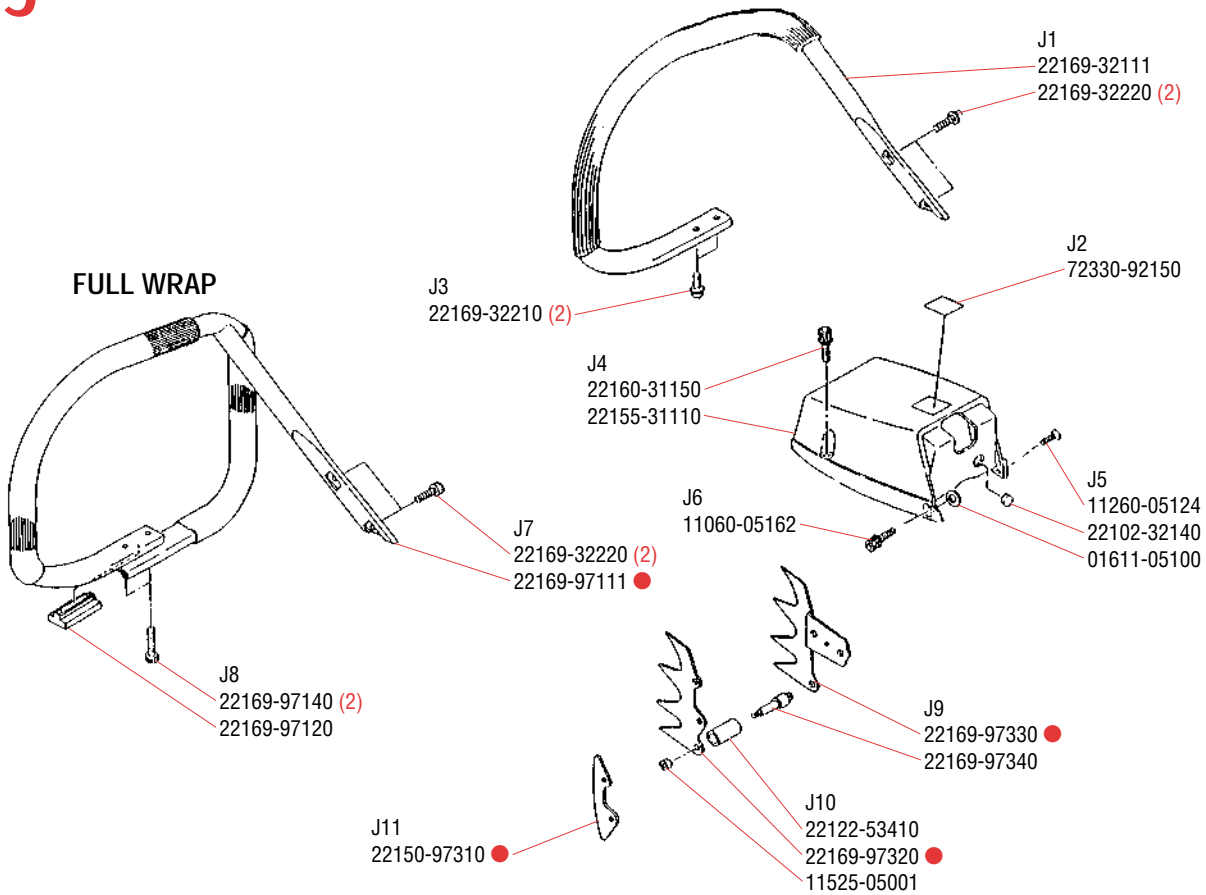

K AIR FILTER/FILTRO AIRE/FILTRO À AIR

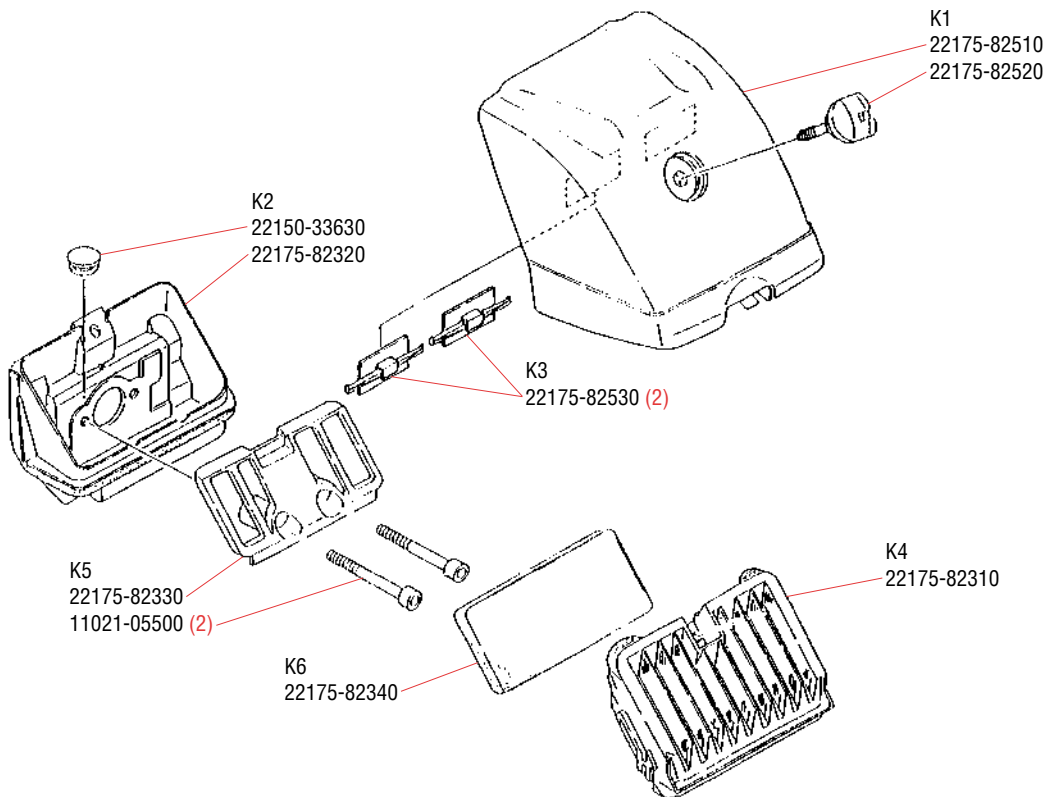

REAR HANDLE/MANGO TRASERO/POIGNÉE ARRIÈRE

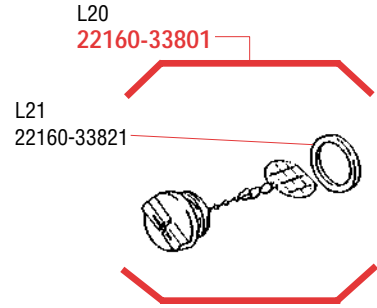
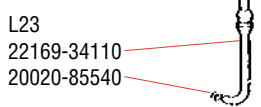
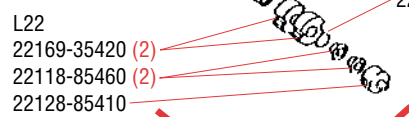
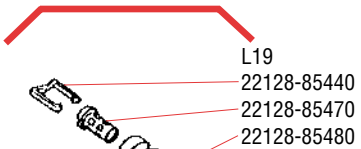
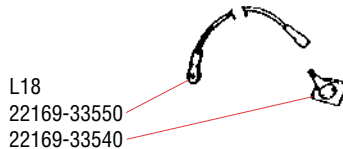
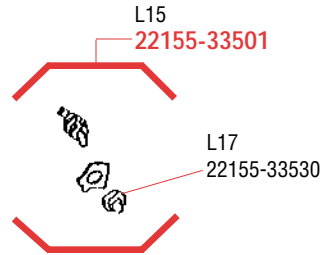
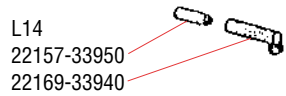
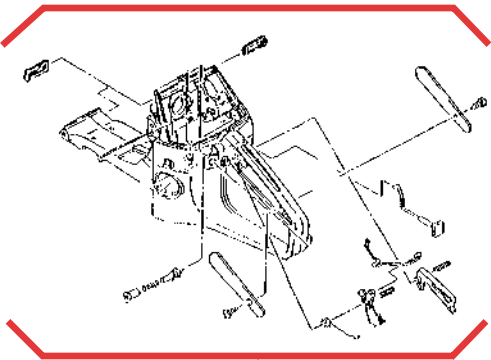
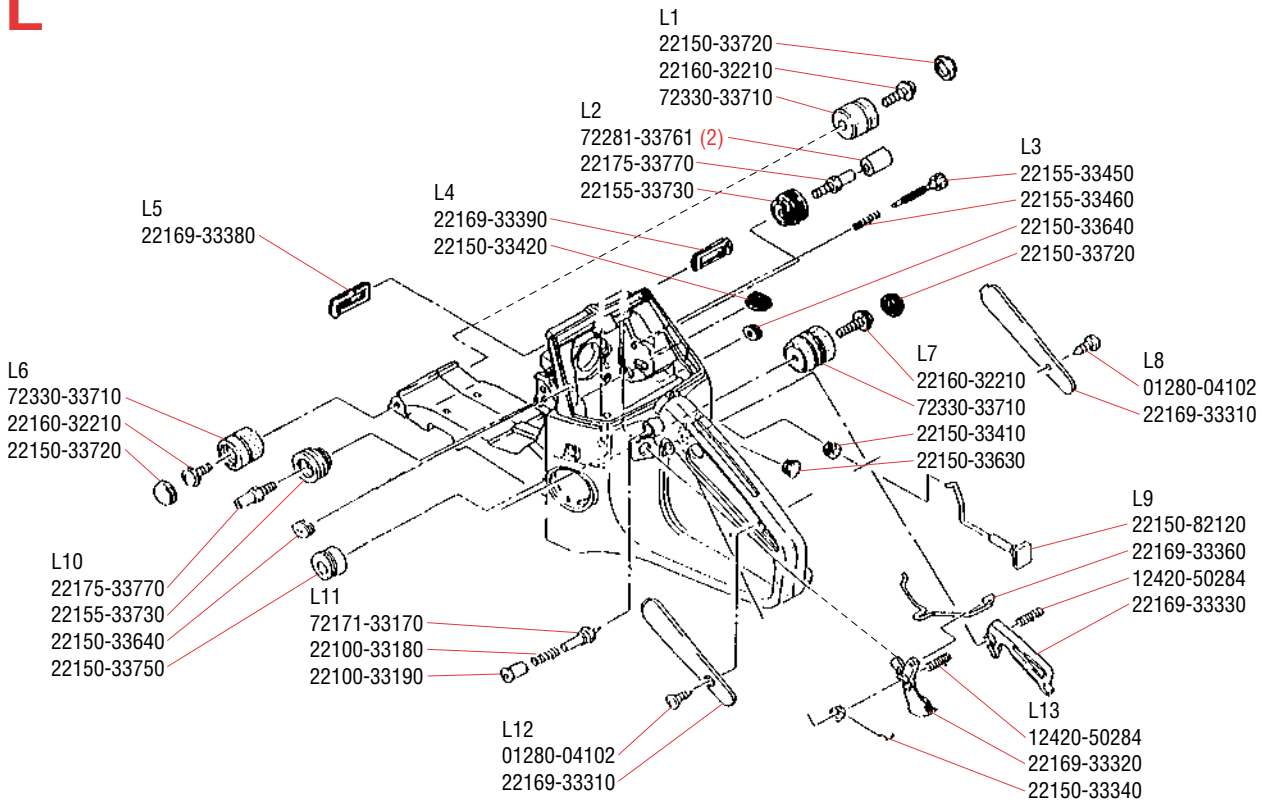

M ACCESSORIES/ACCESORIOS/ACCESSOIRES

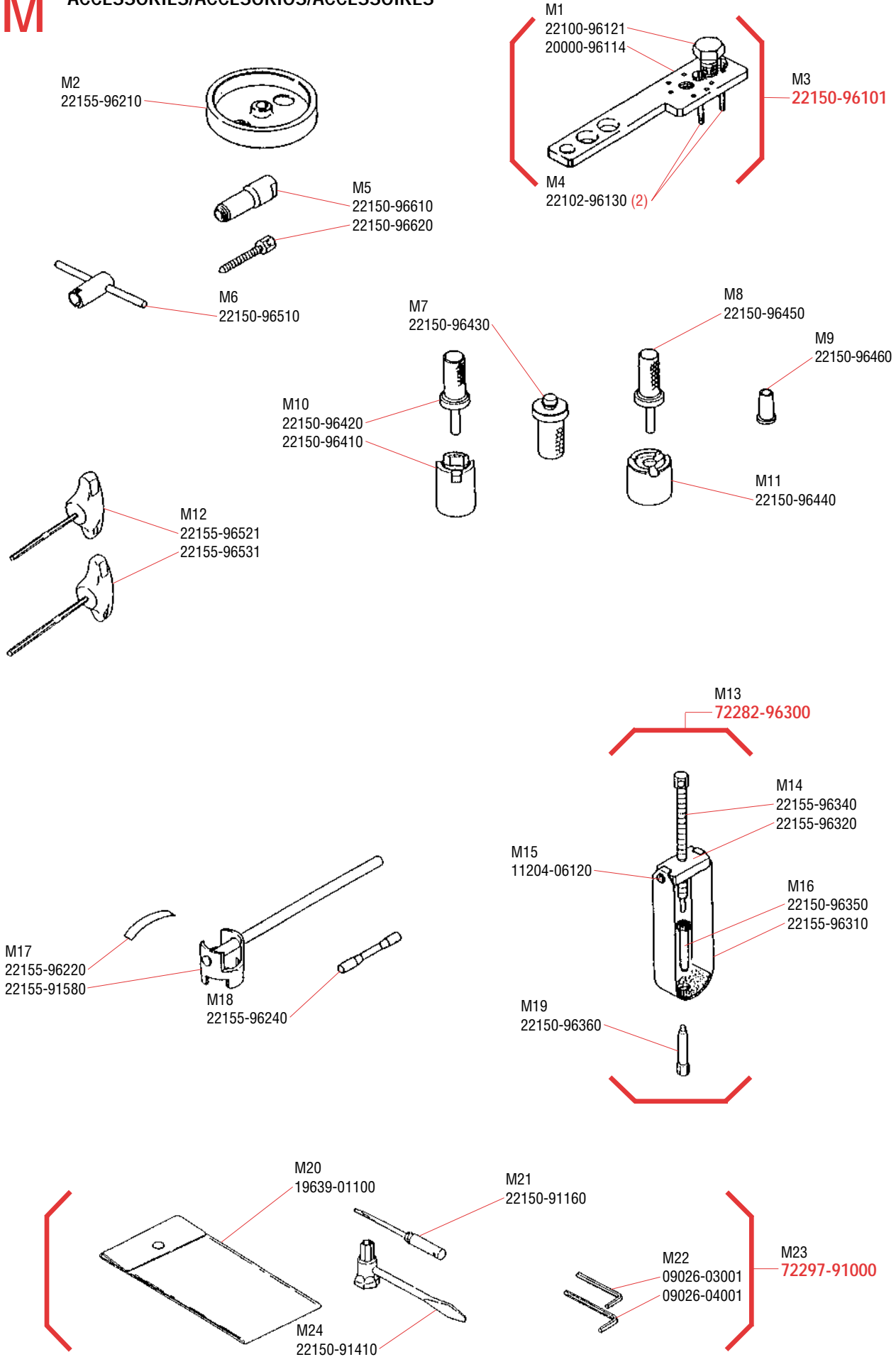

N

CARBURETOR/CARBURADOR/CARBURATEUR

WALBRO HDA 50A

H - 1 1/4
L - 1 1/4

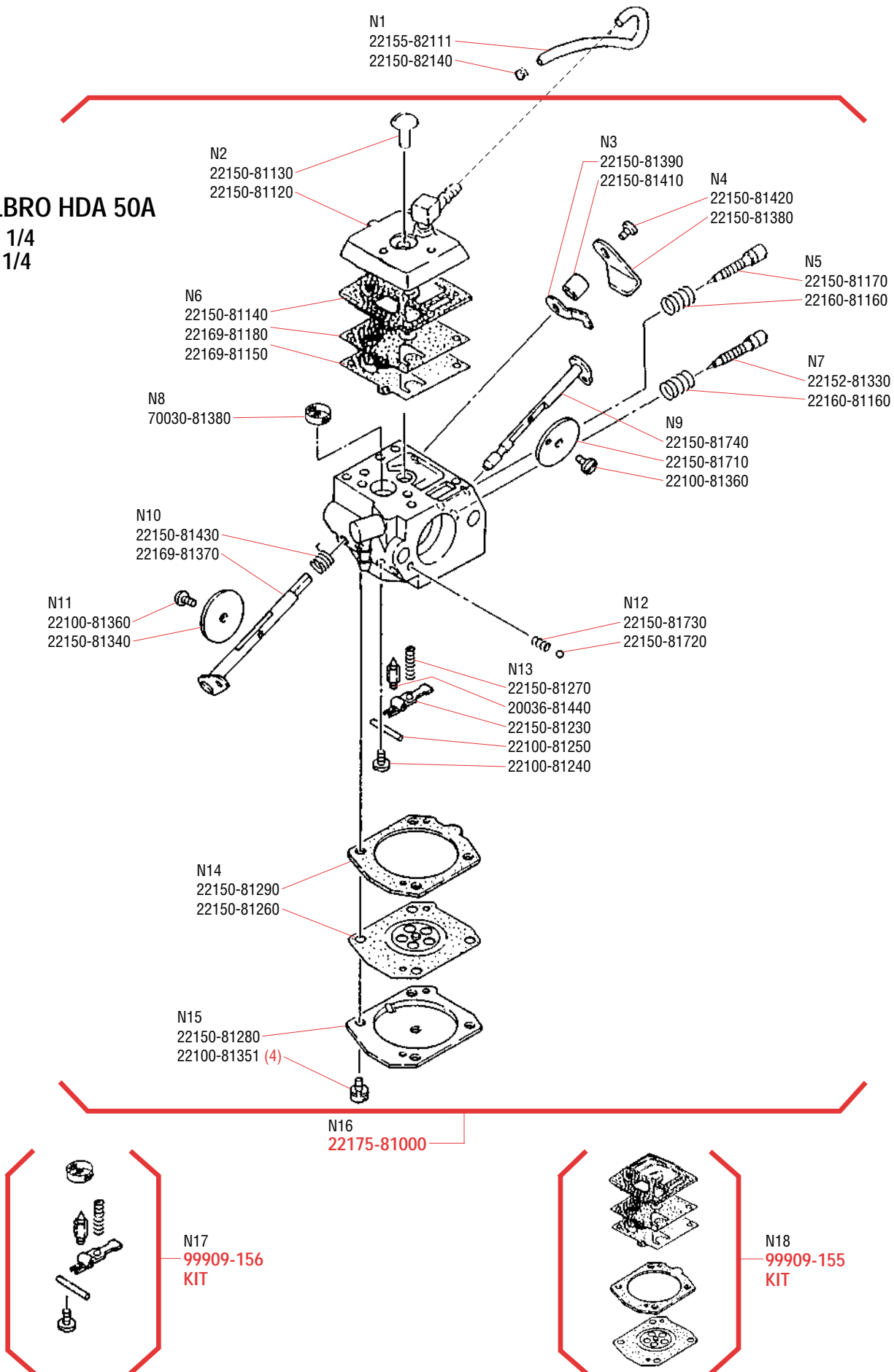

Numerical Parts Listing

Part No.	Description	Index	Part No.	Description	Index	Part No.	Description	Index
01020-05120	BOLT	H7	22150-15412	BOLT	B6	22150-81740	CHOKE ROD	N9
01201-03100	SCREW	H8	22150-21220	IMPULSE CONNECTOR	C7	22150-82120	CHOKE ROD	L9
01201-04160	SCREW	A5	22150-21250	OIL SEAL	C7	22150-82140	CLIP	N1
01201-05120	SCREW	F4	22150-21521	BAR BOLT	C5	22150-91160	SCREW DRIVER	M21
01215-05080	SCREW	B2	22150-33340	THROTTLE SPRING	L13	22150-91410	WRENCH	M24
01280-04102	SCREW	L8	22150-33410	GROMMET, CHOKE	L7	22150-96101	PULLER ASSY.	M3
01280-04102	SCREW	L12	22150-33420	GROMMET	L4	22150-96350	PIN ADAPTER	M16
01610-05080	WASHER	F2	22150-33630	PLUG	K2	22150-96360	GUIDE PIN	M19
01611-05100	WASHER	J5	22150-33630	PLUG	L7	22150-96410	HOLDER (M)	M10
02403-03100	KEY	D5	22150-33640	GROMMET	L3	22150-96420	ROD, OIL SEAL (M)	M10
02427-40125	SPRING PIN	F10	22150-33640	GROMMET	L10	22150-96430	WRENCH	M6
09026-03001	WRENCH	M22	22150-33720	PLUG	L6	22150-96430	ROD 6202	M7
09026-04001	WRENCH	M22	22150-33720	PLUG	L1	22150-96440	HOLDER (C)	M11
11021-05500	CARBURETOR BOLT	K5	22150-33720	PLUG	L3	22150-96450	ROD, OIL SEAL (C)	M8
11022-04160	BOLT	G8	22150-33750	SUPPORT	L10	22150-96460	COLLAR, OIL SEAL	M9
11022-05200	BOLT	G6	22150-41280	NEEDLE BEARING	D4	22150-96610	PULLER (M)	M5
11022-05250	BOLT	H12	22150-42002	CRANKSHAFT ASSY.	D4	22150-96620	BOLT	M5
11060-05162	BOLT	J6	22150-51230	CLUTCH SPRING	E13	22150-97220	RIM SPROCKET	
11060-05500	BOLT	C1	22150-51310	NEEDLE BEARING	E15		3/8"-8	E14
11204-06120	SCREW	M15	22150-51510	CLUTCH DRUM	E11	22150-97310	SPIKE (B)	J11
11205-04100	SCREW	E2	22150-51520	RIM SPROCKET 3/8-7"	E11	22152-12111	CYLINDER	A1
11205-04100	SCREW	F1	22150-52411	NUT	F5	22152-21501	CRANKCASE	
11205-04160	SCREW	E1	22150-52440	ADJUST STUD	F2		ASSY. (S)	C10
11260-05124	SCREW	J5	22150-54311	ADJUST ROD	F10	22152-41112	PISTON	D2
11525-05001	NUT	J10	22150-54320	ADJUST SCREW	F8	22152-41210	RINGS	D2
12420-50284	SPRING	L13	22150-54330	BRAKE SPRING	F8	22152-41220	PISTON PIN	D3
12420-50284	SPRING	L9	22150-54340	WASHER	F8	22152-41230	SNAP RING	D3
12492-50100	DOWEL PIN	C5	22150-54410	BLOCK	F6	22152-41250	THRUST WASHER	D5
12900-62020	BEARING	C7	22150-54520	INNER LEVER	F12	22152-81330	H NEEDLE	N7
12900-62020	BEARING	C8	22150-54630	LEVER SPRING	F9	22155-12190	BOLT	A1
15210-12305	BAND	G7	22150-55120	THRUST PLATE	E3	22155-15210	MUFFLER GASKET	B6
19639-01100	TOOL BAG	M20	22150-55312	OIL TUBE	E4	22155-15420	LOCK PLATE	B1
20000-72230	PLUG SPRING	G2	22150-55411	GASKET	E1	22155-15441	BOLT	B1
20000-96114	LEVER	M1	22150-55421	ELBOW	E5	22155-21630	OIL SEAL	C8
20010-75230	TAPE	H3	22150-71120	RATCHET	G5	22155-31110	ENGINE COVER	J4
20011-12260	NUT	B1	22150-71700	IGNITION COIL	G9	22155-33450	ADJUST SCREW	L3
20020-85540	CLIP	L23	22150-71720	WIRE	G8	22155-33460	SPRING	L3
20036-81440	NEEDLE VALVE	N13	22150-71730	CAP	G8	22155-33501	SWITCH ASSY.	L15
22100-33180	SPRING	L11	22150-75310	REEL	H8	22155-33530	NUT	L17
22100-33190	KNOB	L11	22150-75431	COVER	H9	22155-33730	CUSHION 22	L10
22100-53330	NUT	F4	22150-75450	WASHER	H7	22155-33730	CUSHION 22	L2
22100-71430	WASHER	G4	22150-75510	ROPE	H4	22155-51200	CLUTCH SHOE ASSY.	E10
22100-71441	BOLT	G5	22150-75520	KNOB	H2	22155-51210	CLUTCH BOSS (A)	E12
22100-81240	SCREW	N13	22150-75530	STOPPER	H2	22155-51220	CLUTCH SHOE	E12
22100-81250	PIN	N13	22150-81120	PUMP COVER	N2	22155-51240	CLUTCH BOSS (B)	E13
22100-81351	SCREW	N15	22150-81130	SCREW	N2	22155-51500	CLUTCH DRUM	
22100-81360	SCREW	N9	22150-81140	GASKET, PUMP	N6		ASSY.	E9
22100-81360	SCREW	N11	22150-81170	L NEEDLE	N5	22155-51530	COVER	E11
22100-96121	CENTER BOLT	M1	22150-81230	LEVER	N13	22155-51550	FILTER (B)	E14
22102-32140	PLUG CAP	J5	22150-81260	DIAPHRAGM	N14	22155-52510	CHAIN CATCHER	F2
22102-96130	BOLT	M4	22150-81270	SPRING	N13	22155-53310	ADJUST SCREW	F2
22115-57120	OIL VENT VALVE	C6	22150-81280	COVER	N15	22155-55110	GEAR	E3
22118-85460	SCREEN	L22	22150-81290	GASKET, DIAPHRAGM	N14	22155-55430	FILTER	E7
22120-54220	BOLT BAND	F13	22150-81340	THROTTLE VALVE	N11	22155-56100	PUMP COVER ASSY.	E8
22122-53410	CHAIN CATCHER	J10	22150-81380	THROTTLE LEVER	N4	22155-56110	PUMP COVER	E6
22128-85410	WEIGHT	L22	22150-81390	STOPPER	N3	22155-56120	FILTER	E6
22128-85440	CLIP, FILTER	L19	22150-81410	SPACER	N3	22155-71130	RATCHET SPRING	G4
22128-85470	SLEEVE	L19	22150-81420	SCREW	N4	22155-72220	PLUG CAP	G2
22128-85480	RING	L19	22150-81430	RETURN SPRING	N10	22155-72250	TUBE	G3
22150-12152	BOOT	A2	22150-81710	CHOKE VALVE	N9	22155-72270	GROMMET	G3
22150-12170	SLEEVE	A3	22150-81720	BALL	N12	22155-72280	TUBE	G3
22150-12180	BRACKET	A5	22150-81730	SPRING	N12	22155-75410	RECOIL SPRING	H9

Part No.	Description	Index	Part No.	Description	Index
22155-75610	AIR DEFLECTOR	H6	22169-97140	BOLT	J8
22155-82111	IMPULSE TUBE	N1	22169-97320	SPIKE (W)	J10
22155-91580	CLUTCH SPANNER	M17	22169-97330	SPIKE (C)	J9
22155-96210	SET GAUGE	M2	22169-97340	BOLT	J9
22155-96220	AIR GAP GAUGE	M17	22175-12120	GASKET	A4
22155-96240	PISTON STOP	M18	22175-12140	GASKET	A2
22155-96310	PULLER	M16	22175-21200	CRANKCASE ASSY. (M)	
22155-96320	BOSS	M14	22175-21300	FUEL CAP ASSY.	C3
22155-96340	BOLT	M14	22175-21340	GASKET	C2
22155-96521	T WRENCH, 3MM	M12	22175-33770	LIMITER BOLT	L10
22155-96531	T WRENCH, 4MM	M12	22175-33770	LIMITER BOLT	L2
22155-97610	GUIDE PLATE	F1	22175-54100	CLUTCH COVER ASSY.	F7
22155-97620	GUIDE PLATE (B)	F14	22175-54210	BRAKE BAND	F13
22157-33950	ELEMENT	L14	22175-57380	WEIGHT	E4
22160-31150	BOLT	J4	22175-71110	FLYWHEEL	G1
22160-32210	SCREW	L7	22175-81000	CARBURETOR ASSY.	N16
22160-32210	SCREW	L1	22175-82310	AIR FILTER	K4
22160-32210	SCREW	L6	22175-82320	CLEANER BASE	K2
22160-33801	FUEL CAP ASSY.	L20	22175-82330	CASE COVER	K5
22160-33821	GASKET	L21	22175-82340	FILTER	K6
22160-55200	OIL PUMP ASSY.	E1	22175-82510	CLEANER COVER	K1
22160-81160	SPRING	N7	22175-82520	KNOB	K1
22160-81160	SPRING	N5	22175-82530	SHUTTER PLATE	K3
22169-21910	BOLT	C4	22175-92170	NAME PLATE	F11
22169-32111	FRONT HANDLE	J1	22175-92180	NAME PLATE	H11
22169-32210	BOLT	J3	70030-81380	SCREEN	N8
22169-32220	BOLT	J1	72171-33170	STOPPER	L11
22169-32220	BOLT	J7	72230-15160	ARRESTOR	B3
22169-33100	REAR HANDLE ASSY.	L16	72230-15172	ARRESTOR COVER	B2
22169-33310	SIDE PLATE	L8	72230-52630	SPIKE	C1
22169-33310	SIDE PLATE	L12	72231-54511	LEVER	F3
22169-33320	THROTTLE LEVER	L13	72231-54580	LEVER BOLT	F12
22169-33330	LOCK LEVER	L9	72231-54590	LEVER NUT	F9
22169-33360	THROTTLE ROD	L9	72231-54610	STOPPER PIN	F6
22169-33380	PLUG	L5	72231-54620	COLLAR	F9
22169-33390	PLUG	L4	72238-51120	RIM SPROCKET .325"-9	E14
22169-33540	GROUND TAB	L18	72281-33761	TUBE	L2
22169-33550	GROUND WIRE	L18	72282-15101	MUFFLER ASSY.	B5
22169-33940	TUBE	L14	72282-15310	GUARD, MUFFLER	B4
22169-34110	FUEL TUBE	L23	72282-96300	PULLER ASSY.	M13
22169-35400	FUEL FILTER ASSY.	L24	72297-91000	TOOL BAG	M23
22169-35420	FILTER	L22	72316-54170	PROTECTOR	F14
22169-57360	OIL FILTER	E4	72330-33710	CUSHION 26	L7
22169-71460	NUT	G1	72330-33710	CUSHION 26	L6
22169-71510	EXCITER COIL	G6	72330-33710	CUSHION 26	L1
22169-75101	RECOIL STARTER ASSY.	H1	72330-92150	CAUTION LABEL	J2
22169-75211	RECOIL CASE	H10	99909-155	GASKET/DIAPHRAGM KIT	N18
22169-75230	ROPE GUIDE	H5	99909-156	KWIK KIT	N17
22169-81150	DIAPHRAGM	N6	99909-173	PISTON ASSY.	D1
22169-81180	DIAPHRAGM	N6			
22169-81370	THROTTLE ROD	N10			
22169-97111	FRONT HANDLE	J7			
22169-97120	SPACER	J8			

shindaiwa®

Shindaiwa Inc.

P.O. Box 1090, Tualatin, OR 97062
11975 S.W. Herman Rd., Tualatin, OR 97062

60549-1 — July '94