

0001ET019 SC

Reference	Item number	Qty	Description
1	1140 020 2612	1	Crankcase, fan side (30.2011) □ 2 - 6, 32, 33
2	9503 003 0354	1	Grooved ball bearing 6202
3	0000 988 8600	2	Sleeve
4	9371 470 1058	2	Cylindrical pin 1,8x19
5	0000 963 0902	2	Bushing
6	9640 003 1560	1	Oil seal 15x22x4
7	1140 020 2904	1	Crankcase (1-3) □ 11 - 20, 22
8	1140 020 2912	1	Crankcase (8,9) □ 11 - 20, 23, 24
9	1140 020 2922	1	Crankcase (4-6) □ 11 - 20, 22
10	1140 020 2932	1	Crankcase (7) □ 11 - 19, 21, 22
11	9523 003 4278	1	Grooved ball bearing 15x35x13
12	9640 003 1600	1	Oil seal 15x29.6x4
13	1128 640 9100	1	Valve
14	1120 162 5200	1	Pin
15	1121 162 5205	1	Pin
16	1121 162 5200	1	Pin
17	0000 974 1200	1	Notched pin 2.6x8
18	9371 470 1058	1	Cylindrical pin 1,8x19
19	0000 963 0902	1	Bushing
20	1138 664 2400	2	Collar screw (1-6,8,9)
21	0000 664 2405	2	Collar screw M8 (7)
22	1121 162 5200	1	Pin (1-7)
23	1125 162 5209	1	Pin (8,9)
24	0000 974 1200	1	Notched pin 2.6x8 (8,9)

(1) MS 362, (2) MS 362-Z, (3) MS 362-RZ, (4) MS 362-RVWZ, (5) MS 362-VV, (6) MS 362-VWZ, (7) MS 362 C-B, (8) MS 362 C-Q, (9) MS 362 C-Q Z

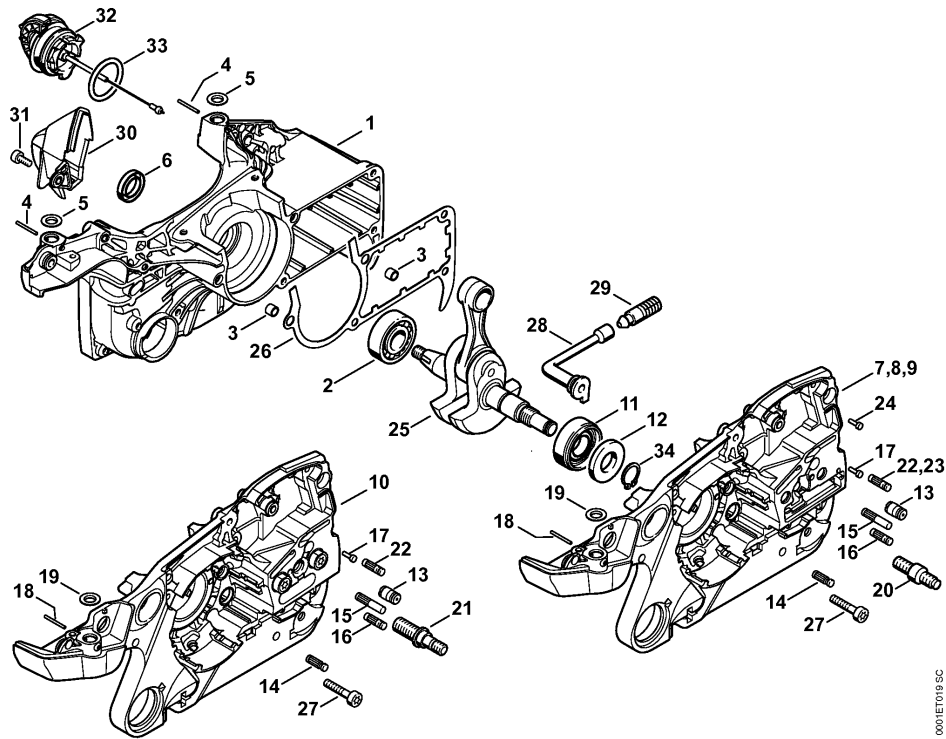

0001ET019 SC

Reference	Item number	Qty	Description
25	1140 030 0400	1	Crankshaft (25.2005)
26	1140 029 0500	1	Gasket
27	9022 371 1050	5	Spline screw IS-M5x25
28	1122 647 9400	1	Hose
29	1117 640 3800	1	Pickup body
30	1140 140 7801	1	Pre-separator
31	9022 346 0658	1	Spline screw IS-M4x12
32	0000 350 0533	1	Filler cap (30.2011) □ 33
33	9645 948 7734	1	O-ring 25x3.5
34	9455 621 1520	1	Circlip 15x1
	1140 007 1001	1	Set of gaskets (B) □ 6, 12, 26

(1) MS 362, (2) MS 362-Z, (3) MS 362-RZ, (4) MS 362-RVWZ, (5) MS 362-VVW, (6) MS 362-VVWZ, (7) MS 362 C-B, (8) MS 362 C-Q, (9) MS 362 C-Q Z

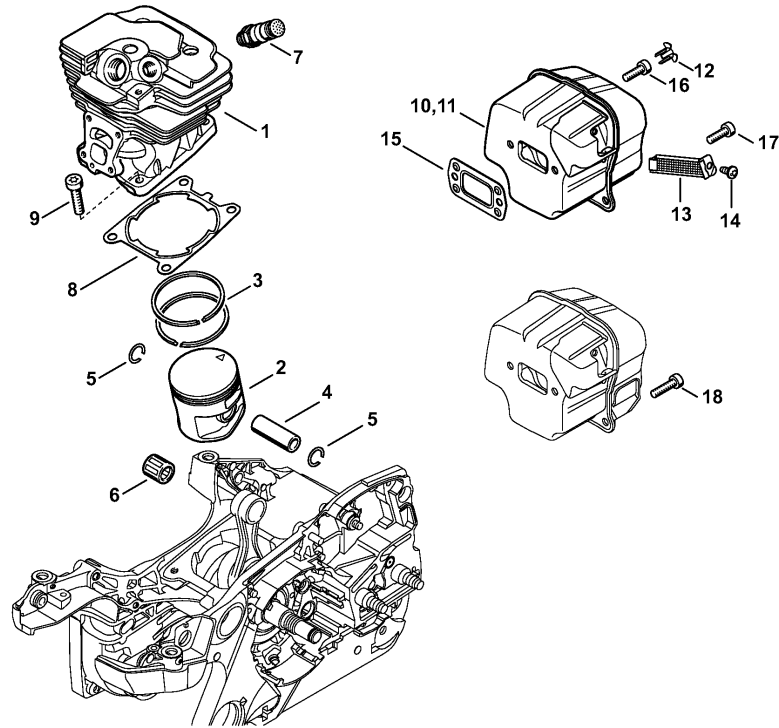

0001ET016 SC

Reference	Item number	Qty	Description
1	1140 020 1200	1	Cylinder with piston Ø 47 mm □ 2 - 5
2	1140 030 2002	1	Piston Ø 47 mm □ 3 - 5
3	1140 034 3000	2	Piston ring Ø 47x1.2 mm
4	1122 034 1500	1	Piston pin 12x8x33
5	9463 650 1200	2	Snap ring 12x1
6	9512 003 3061	1	Needle cage 12x15x15
7	1135 020 9400	1	Decompression valve
8	1140 029 2300	1	Cylinder gasket
9	9022 371 1050	4	Spline screw IS-M5x25
10	1140 140 0655	1	Muffler (1,5,7,8) □ 12, 16, 17
11	1140 140 0654	1	Muffler (2-4,6,9) USDA Cert. I.D. 1140/00 USA, CDN, AUS, NZ □ 12 - 14, 16, 17
12	1135 145 9002	1	Plug USA, CDN, AUS, NZ
13	1140 140 8100	1	Spark arresting screen (2-4,6,9) USA, CDN, AUS, NZ
14	9039 448 0656	1	Self-tapping screw M4x9.6 (2-4,6,9) USA, CDN, AUS, NZ
15	1140 149 0600	1	Muffler gasket
16	9022 341 0983	2	Spline screw IS-M5x16
17	9022 341 0983	2	Spline screw IS-M5x16
18	* 9022 371 1020	2	Spline screw IS-M5x20

(1) MS 362, (2) MS 362-Z, (3) MS 362-RZ, (4) MS 362-RVWZ, (5) MS 362-VVW, (6) MS 362-VWZ, (7) MS 362 C-B, (8) MS 362 C-Q, (9) MS 362 C-Q Z

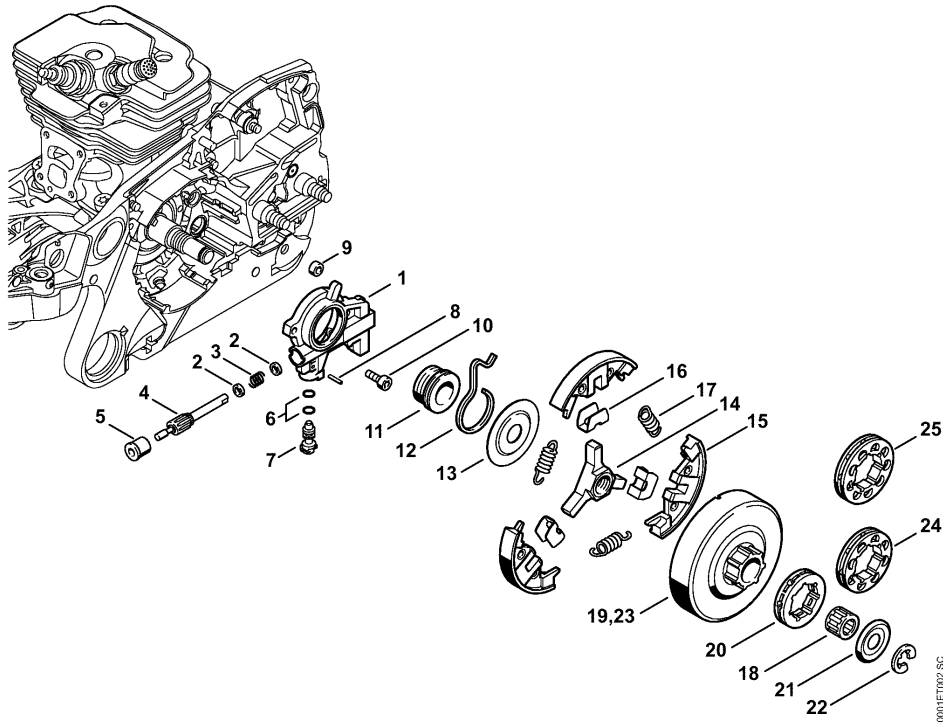

0001ETW02 SC

Reference	Item number	Qty	Description
1	1135 640 3200	1	Oil pump □ 2 - 8
2	0000 958 0518	2	Washer
3	0000 997 0615	1	Compression spring
4	1135 647 0600	1	Pump piston
5	1125 641 9400	1	Bearing bushing
6	9646 945 0160	2	O-ring 4x2
7	1128 647 4806	1	Control bolt
8	9380 620 1090	1	Roll pin 2x10
9	1122 649 5000	1	Sealing ring B4x2
10	9022 313 0660	2	Spline screw IS-M4x12
11	1128 640 7112	1	Worm □ 12
12	1128 647 2400	1	Spring
13	1122 162 1000	1	Cover washer 52 mm / 2 1/16"
	1138 160 2010	1	Clutch □ 14 - 17
14	1128 162 3202	1	Carrier
15	1138 162 0800	3	Clutch shoe
16	1128 162 3000	3	Retainer
17	0000 997 5816	3	Tension spring
18	9512 933 2380	1	Needle cage 10x16x12
	1128 007 1000	1	Rim sprocket kit 3/8" 7T (1-7) □ 19 - 22
19		1	Clutch drum (D) (1-7)
20	0000 642 1223	1	Rim sprocket 3/8" 7T
21	0000 958 1032	1	Washer Ø 27 mm
22	9460 624 0801	1	E-clip 8x1.3
	1135 007 1002	1	Rim sprocket kit 3/8" 7T (8,9) □ 20 - 23
23		1	Clutch drum (D) (8,9)
	1128 007 1001	1	Rim sprocket kit 3/8" 8T (B) (1-7) □ 19, 21, 22, 24
24	0000 642 1216	1	Rim sprocket 3/8" 8T (B) (1-7)
	1128 007 1011	1	Rim sprocket kit 0.325" 9T (B) (1-7) Skand. □ 19, 21, 22, 25
25	0000 642 1239	1	Rim sprocket 0.325" 9T (B) (1-7) Skand.

(1) MS 362, (2) MS 362-Z, (3) MS 362-RZ, (4) MS 362-RVWZ, (5) MS 362-VW, (6) MS 362-VWZ, (7) MS 362 C-B, (8) MS 362 C-Q, (9) MS 362 C-Q Z

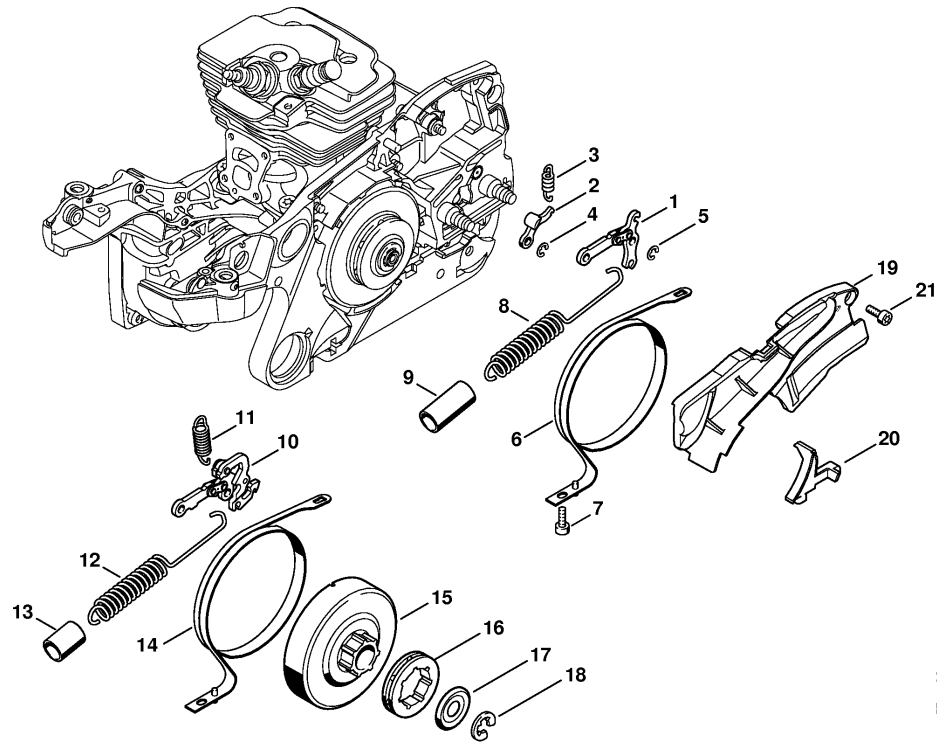

Reference	Item number	Qty	Description
1	1128 160 5000	1	Lever (1-7)
2	1121 162 5010	1	Lever
3	0000 997 0628	1	Spring
4	9460 624 0400	1	E-clip 4
5	9460 624 0400	1	E-clip 4 (1-7)
6	1135 160 5400	1	Brake band (1-7)
7	9022 346 0658	1	Spline screw IS-M4x12
8	1135 160 5500	1	Tension spring (1-7)
			□ 9
9	1140 162 8004	1	Hose (1-7)
10	1133 160 5000	1	Brake lever (8,9)
11	1125 162 7905	1	Tension spring (8,9)
12	1140 160 5500	1	Tension spring (8,9)
			□ 13
13	1140 162 8003	1	Hose (8,9)
14	1135 160 5450	1	Brake band (8,9)
			□ 15 - 18
15		1	Clutch drum (D) (8,9)
16	0000 642 1223	1	Rim sprocket 3/8" 7T (8,9)
17	0000 958 1032	1	Washer Ø 27 mm (8,9)
18	9460 624 0801	1	E-clip 8x1.3 (8,9)
19	1140 021 1100	1	Cover
20	1140 021 1102	1	Cover
21	9022 346 0658	2	Spline screw IS-M4x12

(1) MS 362, (2) MS 362-Z, (3) MS 362-RZ, (4) MS 362-RVWZ, (5) MS 362-VW, (6) MS 362-VWZ, (7) MS 362 C-B, (8) MS 362 C-Q, (9) MS 362 C-Q Z

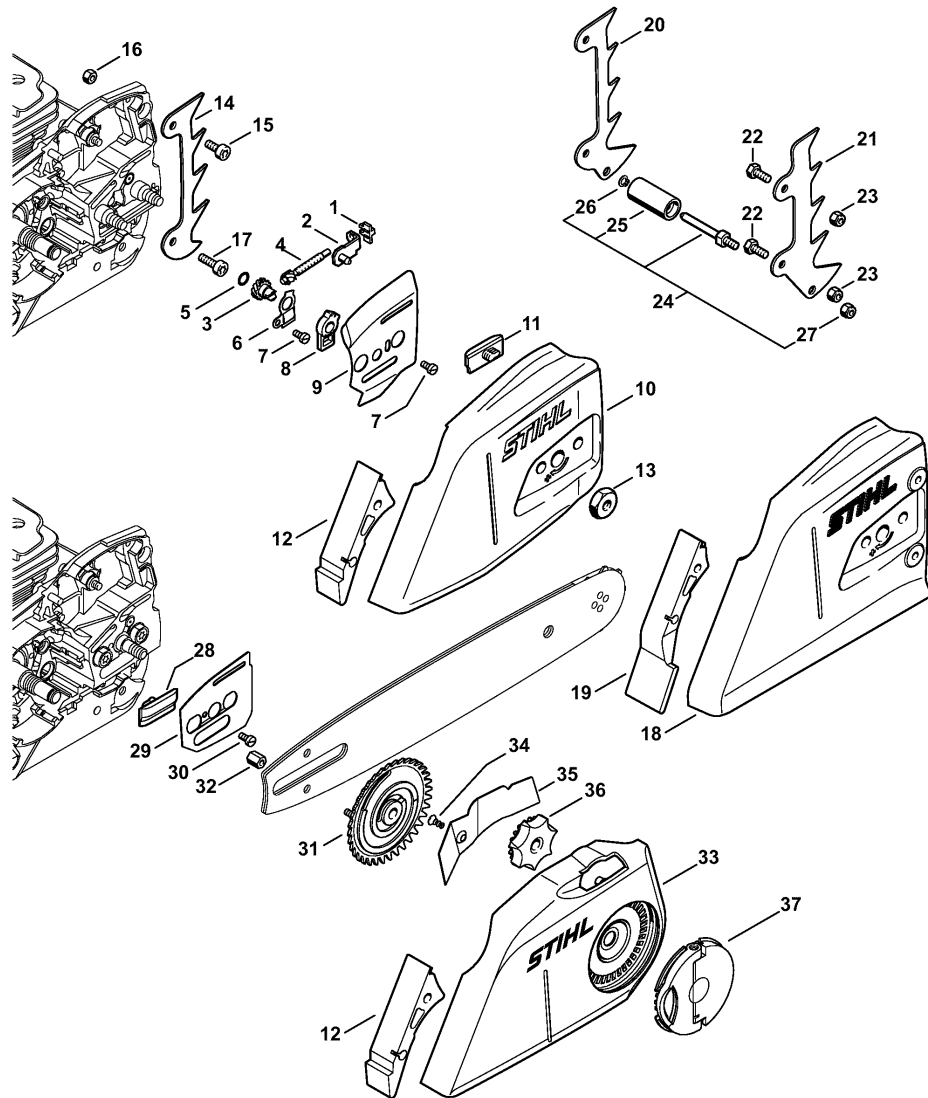

0001ET009 SC

Reference	Item number	Qty	Description
1	1125 664 1400	1	Thrust pad (1-6,8,9)
2	1125 640 1900	1	Tensioner slide (1-6,8,9)
	1125 007 1021	1	Spur gear / chain adjusting screw kit (1-6,8,9) □ 3 - 5
3		1	Spur gear (D) (1-6,8,9)
4		1	Adjusting screw (D) (1-6,8,9)
5	9646 945 0490	1	O-ring 7x1.5 (1-6,8,9)
6	1122 664 2200	1	Cover plate (1-6,8,9)
7	9041 216 0630	2	Pan head screw M4x8 (1-6,8,9)
8	1122 664 4500	1	Support (1-6,8,9)
9	1122 664 1000	1	Inner side plate 0.5 mm (1-6,8,9)
10	1135 640 1703	1	Chain sprocket cover (1,2,5,6,8,9) □ 11, 12
11	1121 648 6610	2	Bumper strip (1-6,8,9)
12	1135 656 1500	1	Guard (1,2,5-9)
13	0000 955 0801	2	Hexagon nut M8 (1,2,5-9)
14	1110 664 0501	1	Bumper spike (1,2,5-9)
15	9022 341 0960	1	Spline screw IS-M5x12
16	9214 320 0700	1	Lock nut M5
17	9022 341 0983	1	Spline screw IS-M5x16
	1135 640 1704	1	Chain sprocket cover (3,4) □ 11, 18, 19
18	1138 648 0400	1	Chain sprocket cover (3,4)
19	1138 656 1500	1	Guard (3,4)
	1135 650 7750	1	Chain catcher (3,4) □ 20 - 27
20	1135 664 0501	1	Bumper spike (3,4)
21	1135 664 0500	1	Bumper spike (3,4)
22	9008 319 0960	2	Hexagon head screw M5x12 (3,4)
23	9214 320 0700	2	Lock nut M5 (3,4)
24	1135 650 7700	1	Chain catcher (3,4) □ 25 - 27
25	1135 656 6600	1	Sleeve (3,4)
26	9452 621 0140	1	Circlip 5x0.8 (3,4)
27	9214 320 0700	1	Lock nut M5 (3,4)

(1) MS 362, (2) MS 362-Z, (3) MS 362-RZ, (4) MS 362-RVWZ, (5) MS 362-VVW, (6) MS 362-VWZ, (7) MS 362 C-B, (8) MS 362 C-Q, (9) MS 362 C-Q Z

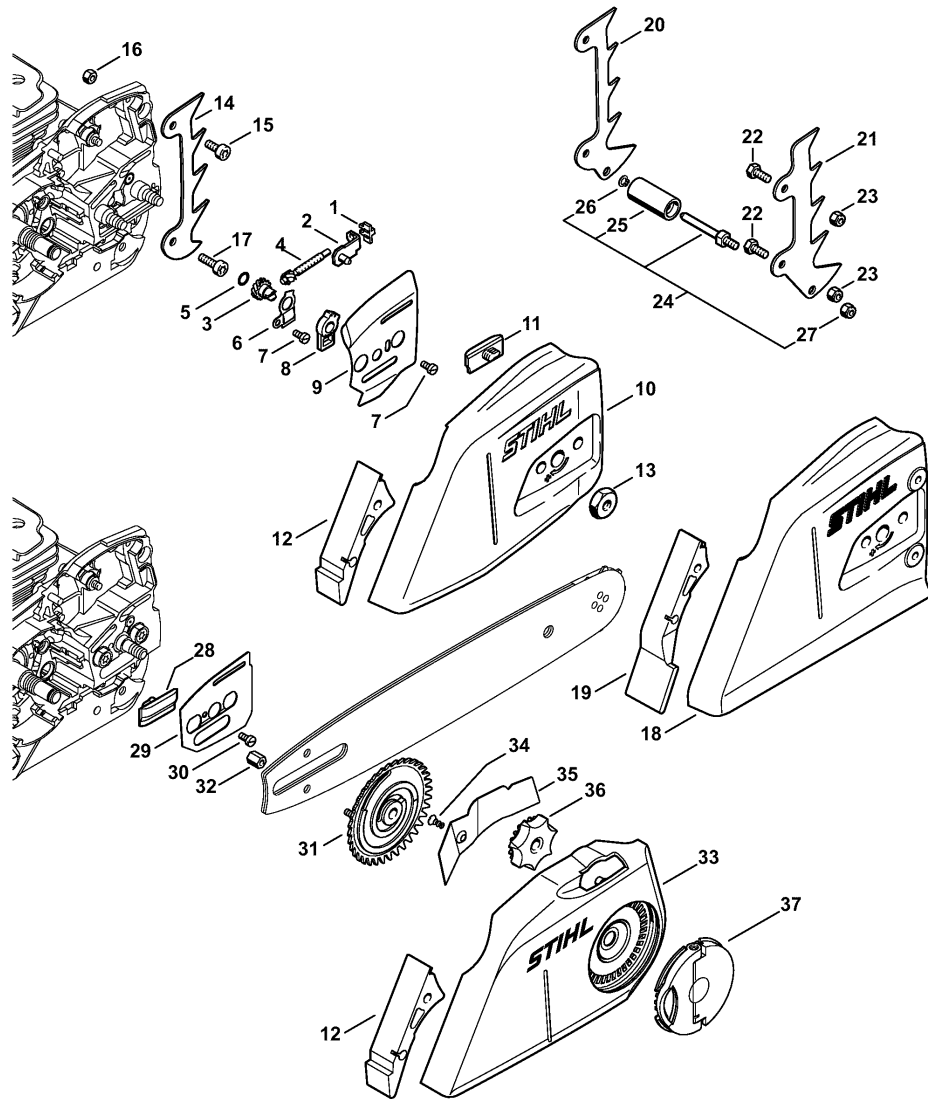

0001ET1009 SC

Reference	Item number	Qty	Description
28	1121 648 6610	1	Bumper strip (7)
29	1121 664 1000	1	Inner side plate (7)
30	9041 216 0630	1	Pan head screw M4x8 (7)
31	1135 660 3000	1	Tensioning gear (7)
			□ 32
32	1121 664 7301	1	Nut M4 (7)
33	1135 640 1702	1	Chain sprocket cover (7)
			□ 12, 34 - 36
34	9076 478 2996	1	Pan head self-tapping screw P4x12 (7)
35	1135 648 3800	1	Cover plate (7)
36	1121 648 2200	1	Adjusting wheel (7)
37	1121 660 1000	1	Wing nut (7)

(1) MS 362, (2) MS 362-Z, (3) MS 362-RZ, (4) MS 362-RVWZ, (5) MS 362-VV, (6) MS 362-VWZ, (7) MS 362 C-B, (8) MS 362 C-Q, (9) MS 362 C-Q Z

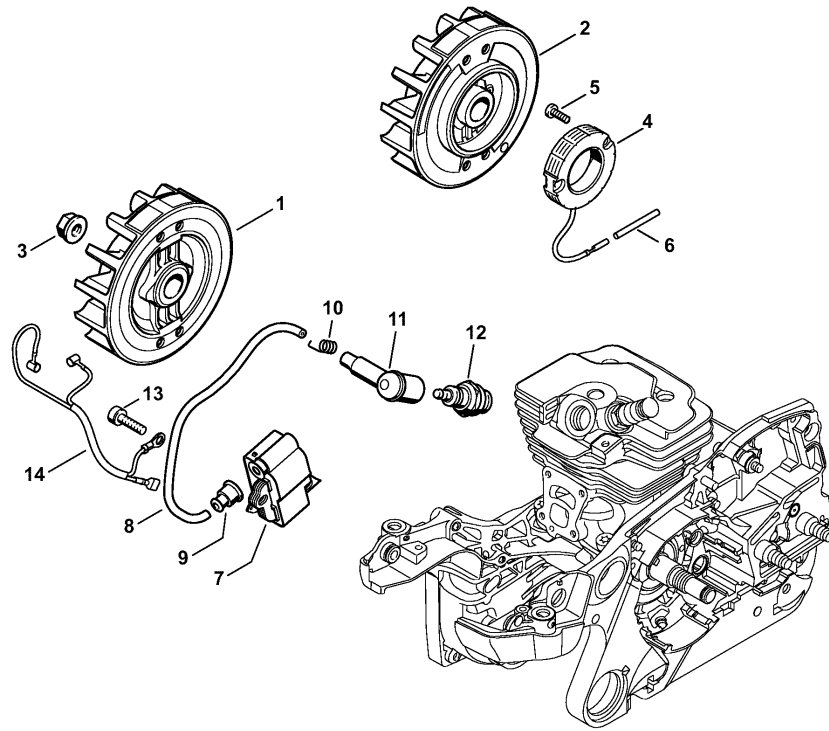

0001E1W04 SC

Reference	Item number	Qty	Description
1	1140 400 1200	1	Flywheel (1-3,7-9) (25.2005)
2	1140 400 1201	1	Flywheel (4-6) (25.2005)
3	0000 955 0802	1	Collar nut M8x1
4	1140 404 3500	1	Generator (4-6)
5	9022 313 0658	2	Spline screw IS-M4x12 (4-6)
6	1121 442 0402	1	Insulating hose 35 mm / 1.4" (4-6)
7	1140 400 1302	1	Ignition module □ 8 - 11
8		1	Ignition lead 207 mm (D)
	0000 405 0600	1	Ignition lead 1 m (A,B)
	0000 930 2251	1	Ignition lead 10 m (A,B)
9	0000 989 1002	1	Grommet
10	0000 998 0603	1	Torsion spring
11	1106 405 1000	1	Spark plug boot
12	0000 400 7000	1	Spark plug NGK BPMR7A
12	1110 400 7005	1	Spark plug Bosch WSR 6 F
13	9022 341 1019	2	Spline screw IS-M5x20
14	1140 440 3000	1	Wiring harness

(1) MS 362, (2) MS 362-Z, (3) MS 362-RZ, (4) MS 362-RVWZ, (5) MS 362-VW, (6) MS 362-VWZ,
(7) MS 362 C-B, (8) MS 362 C-Q, (9) MS 362 C-Q Z

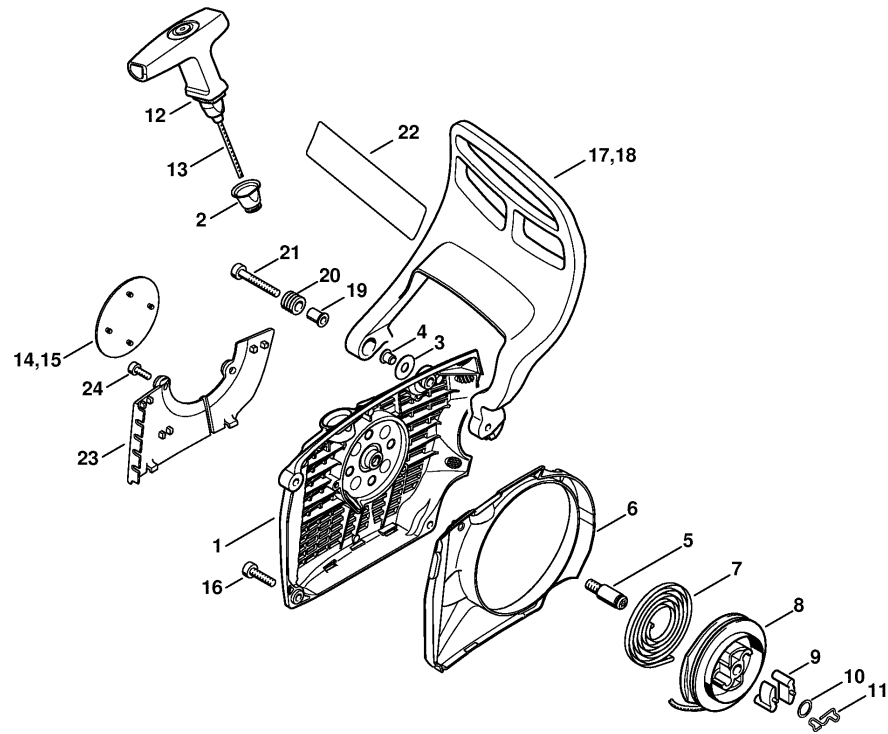

0001ETW05 SC

Reference	Item number	Qty	Description
	1140 080 2103	1	Fan housing with rewind starter □ 1 - 15
1	1140 080 1800	1	Fan housing □ 2 - 5, 10
2	1110 084 9102	1	Bushing
3	0000 958 0607	1	Washer
4	9416 868 6530	1	Hollow rivet 6.5x0.5x6.8
5	1128 080 6500	1	Axle □ 10
6	1140 084 7800	1	Segment
7	1135 190 0600	1	Rewind spring
8	1128 195 0400	1	Rope rotor
9	1125 195 7200	2	Pawl
10	0000 958 0923	1	Washer
11	1128 195 3500	1	Spring
12	1128 190 3400	1	Starter grip ElastoStart Ø 3,5 mm □ 13
13	1128 190 2900	1	Starter rope Ø 3.5 mm
	0000 930 2267	1	Starter rope Ø 3.5 mm / 28 pieces (A,B)
14	1140 967 1500	1	Model plate MS 362 (1-6)
15	1140 967 1503	1	Model plate MS 362 C (7-9)
16	9022 371 1020	3	Spline screw IS-M5x20
17	1140 792 9100	1	Hand guard (1-7)
18	1140 792 9102	1	Hand guard (8,9)
19	1124 792 5500	1	Bushing
20	1124 792 5505	1	Bushing
21	9022 341 1080	1	Spline screw IS-M5x35
22	0000 967 3630	1	Instruction label USA
23	1140 007 1002	1	Cover plate kit (B) □ 24
24	9075 478 3015	2	Pan head self-tapping screw IS-D4x15 (B)

(1) MS 362, (2) MS 362-Z, (3) MS 362-RZ, (4) MS 362-RVWZ, (5) MS 362-VW, (6) MS 362-VWZ, (7) MS 362 C-B, (8) MS 362 C-Q, (9) MS 362 C-Q Z

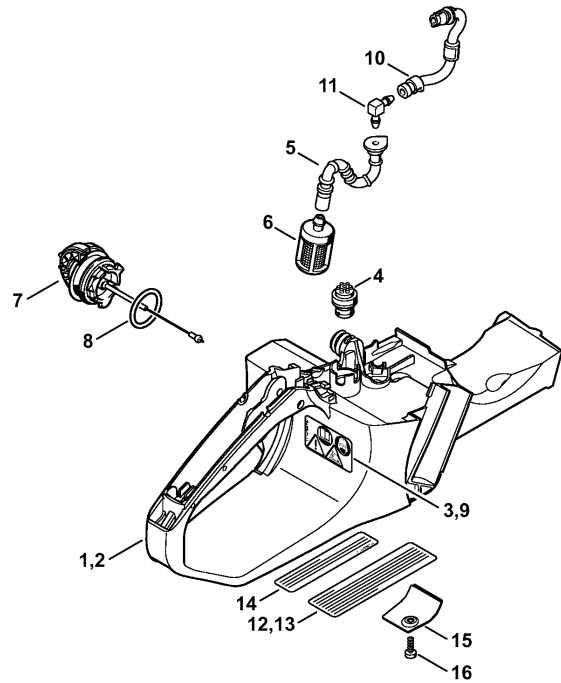

0001ETW06 SC

Reference	Item number	Qty	Description
1	1140 350 0807	1	Tank housing (1-7) (30.2011) □ 3 - 8
2	1140 350 0812	1	Tank housing (8,9) (30.2011) □ 4 - 9
3	0000 967 3662	1	Warning pictogram MS (1-7)
4	0000 350 5800	1	Tank vent
5	1140 358 7706	1	Hose
6	0000 350 3504	1	Pickup body
7	0000 350 0533	1	Filler cap (30.2011) □ 8
8	9645 948 7734	1	O-ring 25x3.5
9	1125 967 3419	1	Warning pictogram QS (8,9)
10	1140 350 2701	1	Fuel hose
11	4224 122 3900	1	Elbow connector
12	0000 967 4012	1	Instruction label (9) USA
13	0000 967 4019	1	Instruction label (9) CDN
14	0000 967 3500	1	Instruction label (2,3) USA
15	1140 656 1500	1	Guard (B)
16	9074 478 2970	1	Pan head self-tapping screw IS-P4x10 (B)

(1) MS 362, (2) MS 362-Z, (3) MS 362-RZ, (4) MS 362-RVWZ, (5) MS 362-VW, (6) MS 362-VWZ, (7) MS 362 C-B, (8) MS 362 C-Q, (9) MS 362 C-Q Z

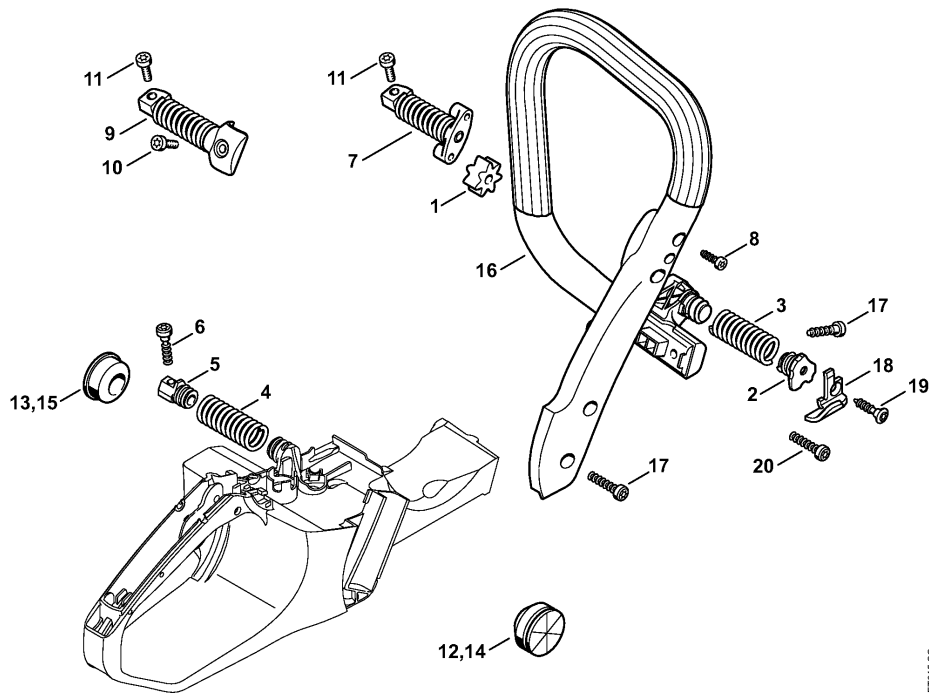

0001ET01015 SC

Reference	Item number	Qty	Description
1	1140 791 2800	1	Stop buffer
2	1140 792 2900	1	Bearing plug
3	1140 791 3100	1	Spring
4	1140 791 3102	1	Spring
5	1140 792 2903	1	Bearing plug
6	9074 478 4475	1	Pan head self-tapping screw IS-P6x21.5
7	1140 790 8300	1	AV-Spring (1,2,7-9)
8	9074 477 4130	2	Pan head self-tapping screw IS-P5x16 (1,2,7-9)
9	1140 790 8301	1	AV-Spring (3-6)
10	9022 341 0980	1	Spline screw IS-M5x16 (3-6)
11	9022 341 0983	1	Spline screw IS-M5x16
12	1138 791 5903	1	Stop buffer (1,2,5-9)
13	1138 791 5902	1	Stop buffer (1,2,5-9)
14	1140 791 5901	1	Stop buffer (3,4)
15	1140 791 5900	1	Stop buffer (3,4)
16	1140 791 1700	1	Handlebar (1,2,7-9)
17	9074 478 4545	4	Pan head self-tapping screw IS-P6x26.5 (1,2,7-9)
18	0000 656 7700	1	Chain catcher (1,2,5-9)
19	9074 477 4438	1	Pan head self-tapping screw IS-P6x30 (1,2,5-9)
20	9074 477 4540	1	Pan head self-tapping screw IS-P6x25 (3,4)

(1) MS 362, (2) MS 362-Z, (3) MS 362-RZ, (4) MS 362-RVWZ, (5) MS 362-VW, (6) MS 362-VWZ, (7) MS 362 C-B, (8) MS 362 C-Q, (9) MS 362 C-Q Z

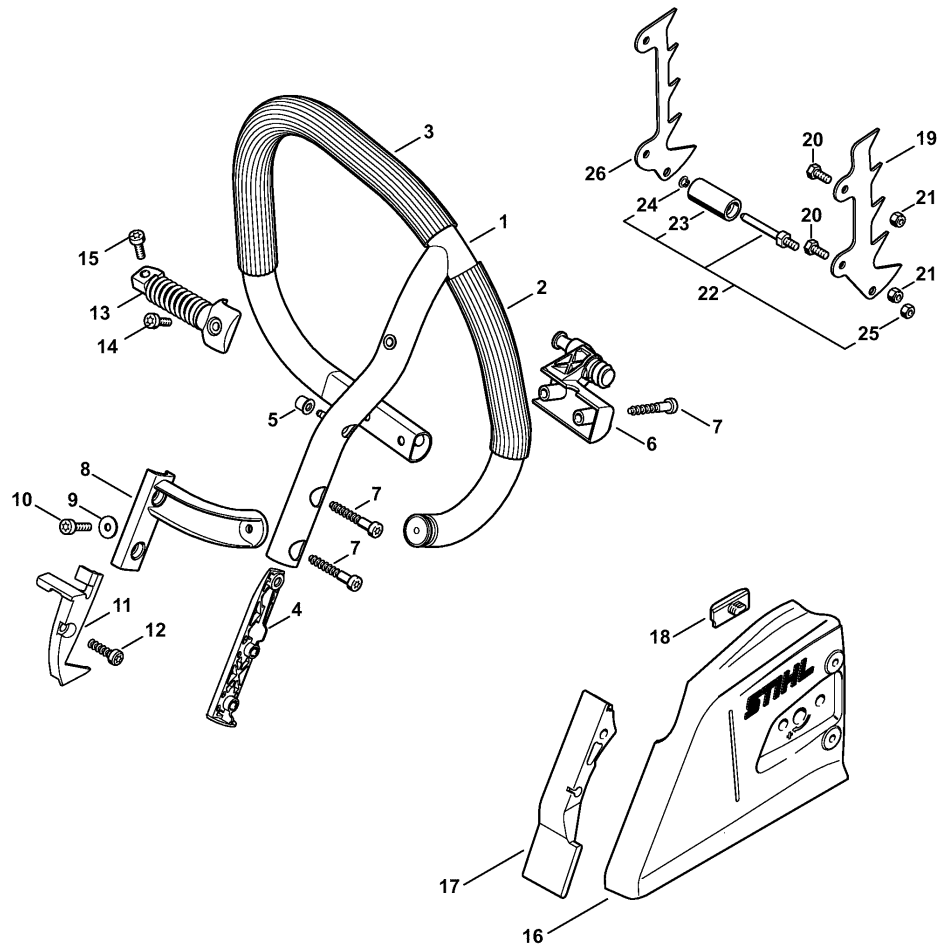

0001ET1008 SC

Reference	Item number	Qty	Description
	1140 007 1000	1	Set wrap around handlebar (B) □ 1 - 26
1	1140 790 3700	1	Wrap around handlebar with hose (3) □ 2 - 5
2		1	Handle hose 155 mm / 6 1/8" (B,D) (3)
3		1	Handle hose 360 mm / 14 3/16" (B,D) (3)
	0000 791 2009	1	Handle hose Ø 19 mm x 5 m / 3/4x197" (A,B) (3)
4	1140 791 5100	1	Stiffener (3,4)
5	0000 791 7900	1	Bushing (3,4)
6	1140 791 1900	1	Handlebar support (3,4)
7	9074 478 4705	4	Pan head self-tapping screw IS-P6x40 (3,4)
8	1140 791 5500	1	Elbow connector (3,4)
9	9307 021 0120	1	Washer 5.3 (3,4)
10	9022 371 1020	1	Spline screw IS-M5x20 (3,4)
11	1140 791 7500	1	Cover (3,4)
12	9074 478 4475	1	Pan head self-tapping screw IS-P6x21.5 (3,4)
13	1140 790 8301	1	AV-Spring (3,4)
14	9022 341 0980	1	Spline screw IS-M5x16 (3,4)
15	9022 341 0983	1	Spline screw IS-M5x16 (3,4)
	1135 640 1704	1	Chain sprocket cover (3,4) □ 16 - 25
16	1138 648 0400	1	Chain sprocket cover (3,4)
17	1138 656 1500	1	Guard (3,4)
18	1121 648 6610	1	Bumper strip (3,4)
19	1135 664 0500	1	Bumper spike (3,4)
20	9008 319 0960	2	Hexagon head screw M5x12 (3,4)
21	9214 320 0700	2	Lock nut M5 (3,4)
	1135 650 7750	1	Chain catcher (B) (3,4) □ 19 - 26
22	1135 650 7700	1	Chain catcher (3,4) □ 23 - 25
23	1135 656 6600	1	Sleeve (3,4)
24	9452 621 0140	1	Circlip 5x0.8 (3,4)
25	9214 320 0700	1	Lock nut M5 (3,4)
26	1135 664 0501	1	Bumper spike (3,4)

(1) MS 362, (2) MS 362-Z, (3) MS 362-RZ, (4) MS 362-RVWZ, (5) MS 362-VW, (6) MS 362-VWZ, (7) MS 362 C-B, (8) MS 362 C-Q, (9) MS 362 C-Q Z

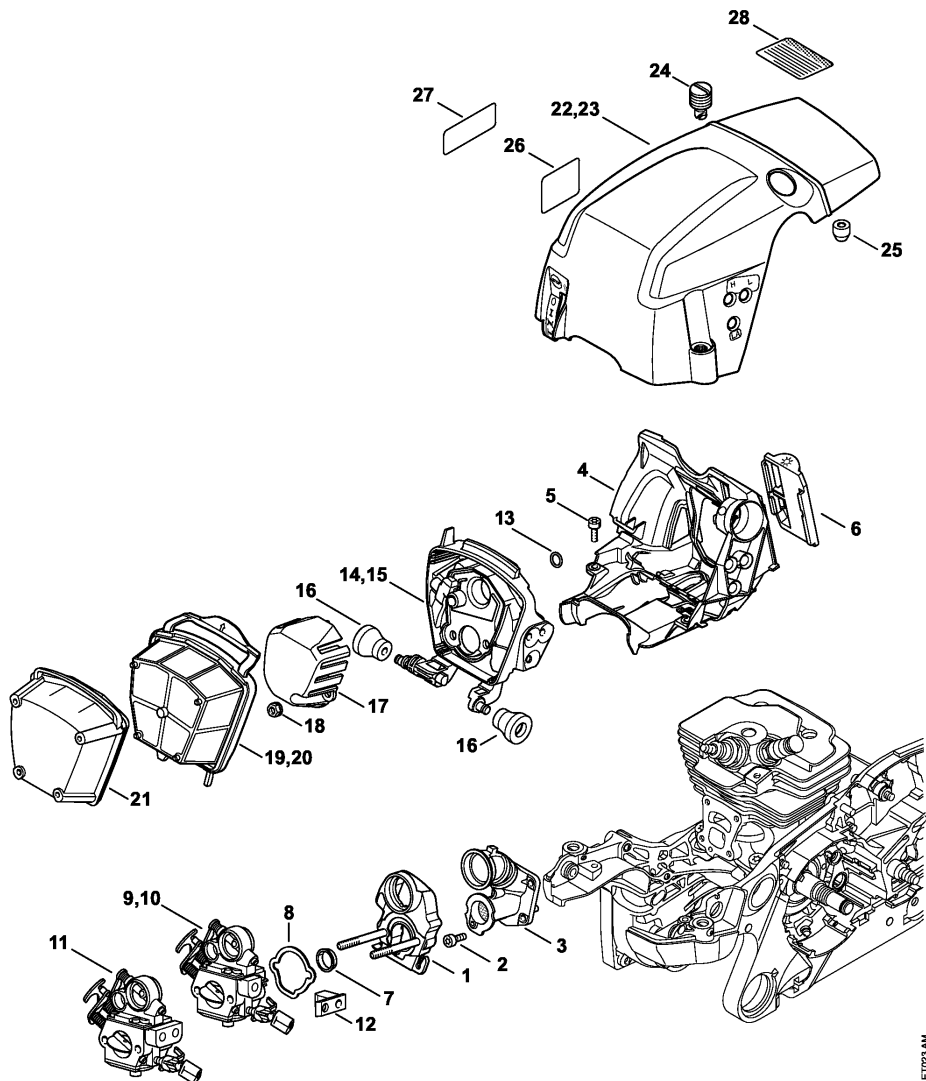

Reference	Item number	Qty	Description
1	1140 120 0903	1	Carburetor bracket
2	9022 313 0660	4	Spline screw IS-M4x12
3	1140 140 2500	1	Manifold
4	1140 080 0900	1	Air guide shroud
5	9022 313 0660	2	Spline screw IS-M4x12
6	1140 084 4100	1	Shutter
7	1140 141 1800	1	Sleeve
8	1140 121 8600	1	Washer (1-3,7-9)
9	1140 120 0600	1	Carburetor WTE-8A (1,5,7,8)
9	1140 120 0600	1	Carburetor WTE-8A (2) AUS, NZ
10	* 1140 120 0600	1	Carburetor WTE-8A (2-4,6,9) USA, CDN
11	1140 120 0606	1	Carburetor WTE-18 (2-4,6,9) USA, CDN
12	1140 123 7501	1	Grommet
13	9645 945 3094	1	O-ring 9x1.5
14	1140 124 3500	1	Filter housing (1-3,7-9)
15	1140 124 3502	1	Filter housing (4-6)
16	1140 122 9900	2	Buffer
17	1140 121 6900	1	Baffle
18	9216 261 0700	2	Hexagon nut M5
19	1140 140 4401	1	Air filter, fleece
20	1140 140 4402	1	Air filter PA (4-6)
21	1140 140 4500	1	Prefilter
22	1140 080 1625	1	Shroud (1-3,7-9)
23	1140 080 1626	1	Shroud (4-6)
24	1140 140 9200	3	Twist lock
25	1121 084 7100	1	Cap
26	0000 967 4058	1	Warning pictogram Filler cap (2-4,6,9) USA
27	* 0000 967 3749	1	Warning pictogram Filler cap (2-4,6,9) USA (30.2011)
28	0000 967 4055	1	Warning Spark arresting screen (2,3,6,9) USA

(1) MS 362, (2) MS 362-Z, (3) MS 362-RZ, (4) MS 362-RVWZ, (5) MS 362-VW, (6) MS 362-VWZ, (7) MS 362 C-B, (8) MS 362 C-Q, (9) MS 362 C-Q Z

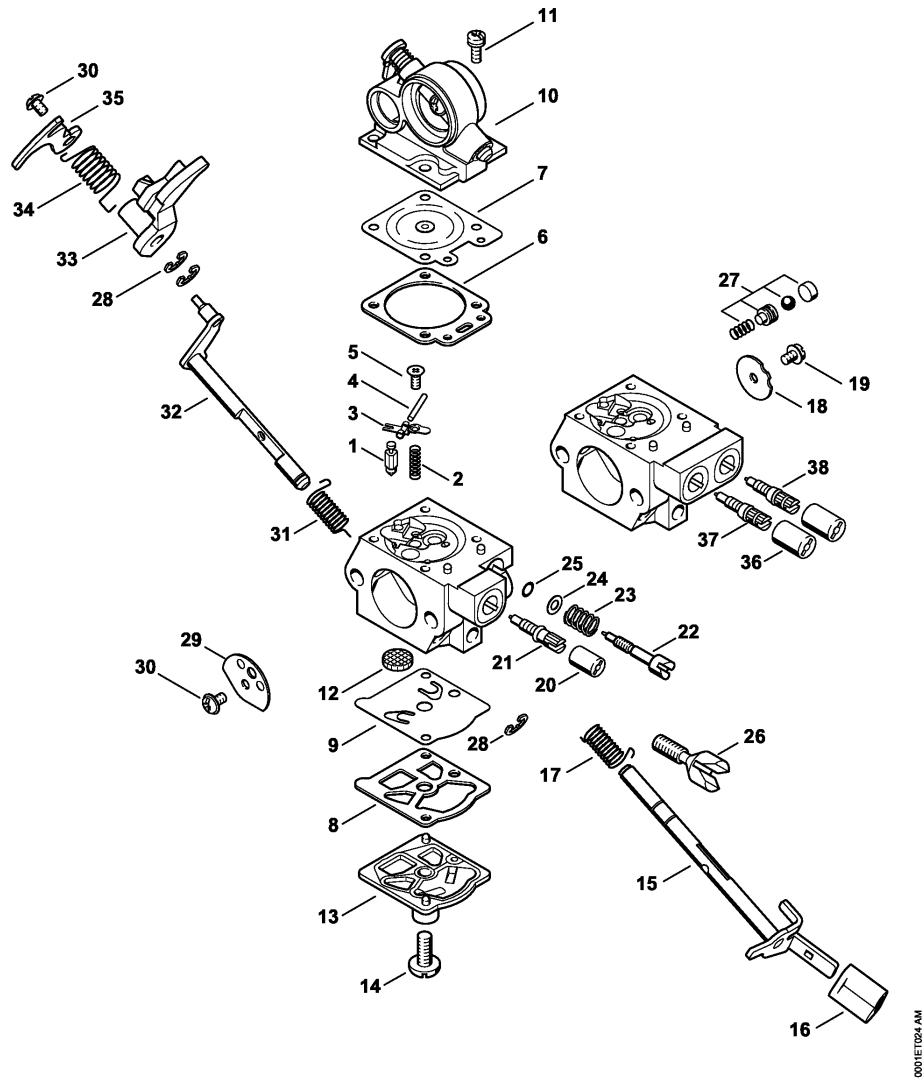

Reference	Item number	Qty	Description
	1140 120 0600	1	Carburetor WTE-8A (1,5,7,8) □ 1 - 35
	1140 120 0600	1	Carburetor WTE-8A (2) AUS, NZ □ 1 - 35
*	1140 120 0600	1	Carburetor WTE-8A (2-4,6,9) USA, CDN □ 1 - 35
	1140 120 0606	1	Carburetor WTE-18 (2-4,6,9) USA, CDN □ 1 - 19, 26 - 38
1	4116 121 5100	1	Inlet needle
2	4116 122 3000	1	Spring
3	1121 121 5000	1	Inlet control lever
4	1113 121 9200	1	Spindle
5	1121 122 7103	1	Round head screw
6	4133 129 0901	1	Gasket
7	1121 121 4700	1	Metering diaphragm
8	1120 129 0905	1	Gasket
9	1121 121 4801	1	Pump diaphragm
10	1140 120 0202	1	Air valve housing
11	1121 122 7101	4	Screw
12	1114 121 7800	1	Strainer
13	1140 120 0800	1	End cover
14	1114 122 7100	1	Screw
15	1140 120 7100	1	Throttle shaft with lever □ 16
16	1140 121 2700	1	Cap
17	1140 122 3200	1	Torsion spring
18	1140 121 3300	1	Throttle shutter
19	4224 122 7801	1	Oval head screw
20	4203 121 2700	1	Cap
21	1140 122 6700	1	High speed adjustment screw
22	1140 122 6800	1	Low speed adjustment screw
23	1115 122 3002	1	Spring
24	1111 121 8605	1	Washer
25	4124 122 3600	1	Sealing ring
26	1140 122 6200	1	Idle speed adjustment screw
27	1140 120 9700	1	Pump piston kit
28	1117 122 9000	3	E-clip
29	1140 121 2900	1	Choke shutter
30	1121 122 7102	2	Round head screw
31	1140 122 3201	1	Torsion spring
32	1140 120 7200	1	Choke shaft with lever

(1) MS 362, (2) MS 362-Z, (3) MS 362-RZ, (4) MS 362-RVWZ, (5) MS 362-VVW, (6) MS 362-VWZ, (7) MS 362 C-B, (8) MS 362 C-Q, (9) MS 362 C-Q Z

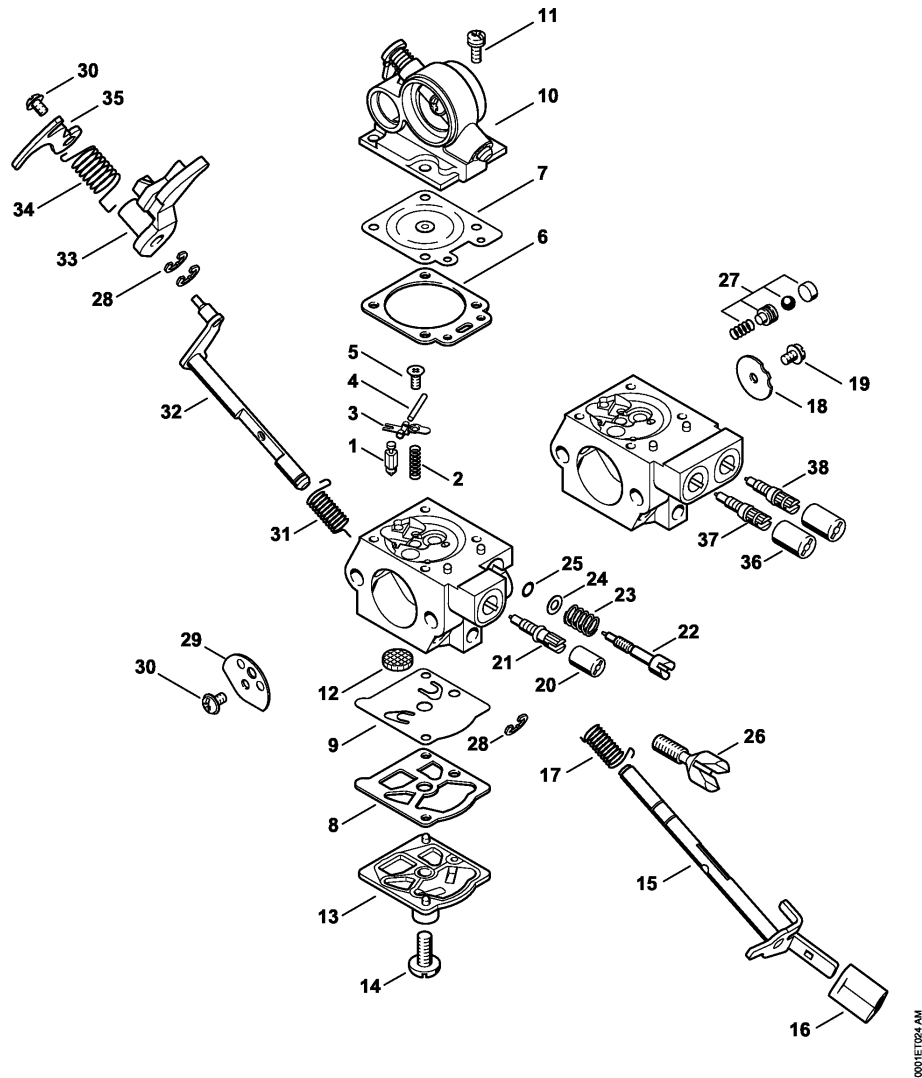

0001E1024 AM

Reference	Item number	Qty	Description
33	1140 121 3500	1	Throttle lever
34	1140 122 3202	1	Torsion spring
35	1140 121 3501	1	Throttle lever
36	0000 121 2701	2	Cap (2-4,6,9) USA, CDN
37	1140 120 6701	1	High speed adjustment screw (2-4,6,9) USA, CDN □ 36
38	1140 120 6801	1	Low speed adjustment screw (2-4,6,9) USA, CDN □ 36
	1140 007 1004	1	Set of carburetor parts □ 6 - 9

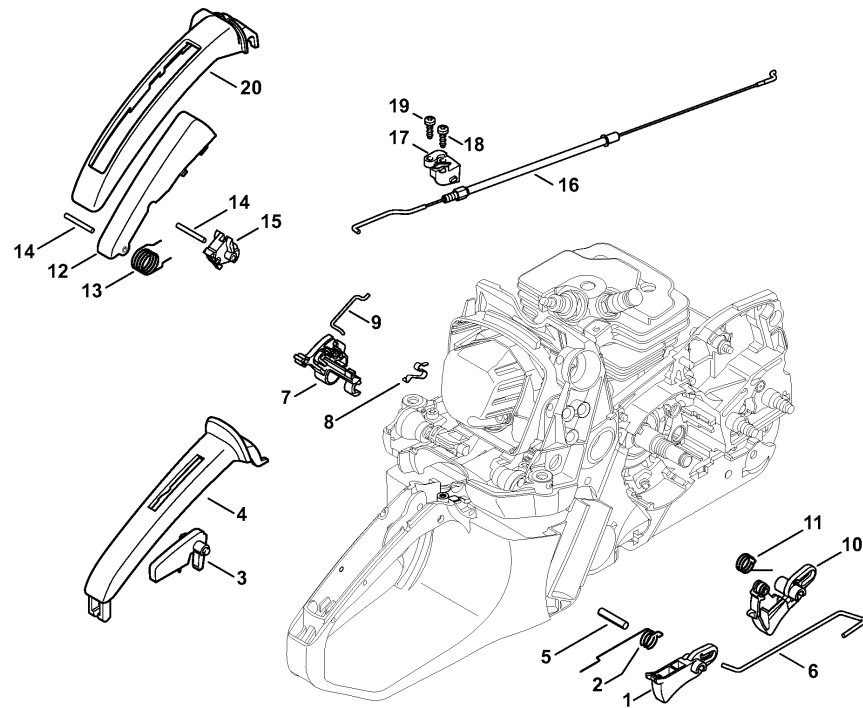

0001ET014 SC

Reference	Item number	Qty	Description
1	1140 182 1000	1	Throttle trigger (1-7)
2	1117 182 4500	1	Torsion spring (1-7)
3	1138 182 0800	1	Lockout lever (1-7)
4	1140 791 0600	1	Handle molding (1-7)
5	9371 470 2640	1	Cylindrical pin 5x24
6	1140 182 1500	1	Throttle rod
7	1140 182 0900	1	Switch shaft
8	1140 442 1600	1	Contact spring
9	1140 185 1900	1	Choke rod
10	1140 180 1500	1	Throttle trigger (8,9)
11	1125 182 4505	1	Torsion spring (8,9)
12	1125 180 1703	1	Lockout lever (8,9)
13	1125 182 4502	1	Torsion spring (8,9)
14	9517 003 0650	2	Cylindrical roller 3x25.8 (8,9)
15	1125 180 1405	1	Trigger switch (8,9)
16	1140 160 2500	1	Brake cable (8,9)
17	1140 182 1600	1	Support (8,9)
18	9074 477 2995	1	Pan head self-tapping screw IS-P4x12 (8,9)
19	9074 477 2995	1	Pan head self-tapping screw IS-P4x12 (8,9)
20	1140 791 0602	1	Handle molding (8,9)

(1) MS 362, (2) MS 362-Z, (3) MS 362-RZ, (4) MS 362-RVWZ, (5) MS 362-VV, (6) MS 362-VWZ, (7) MS 362 C-B, (8) MS 362 C-Q, (9) MS 362 C-Q Z

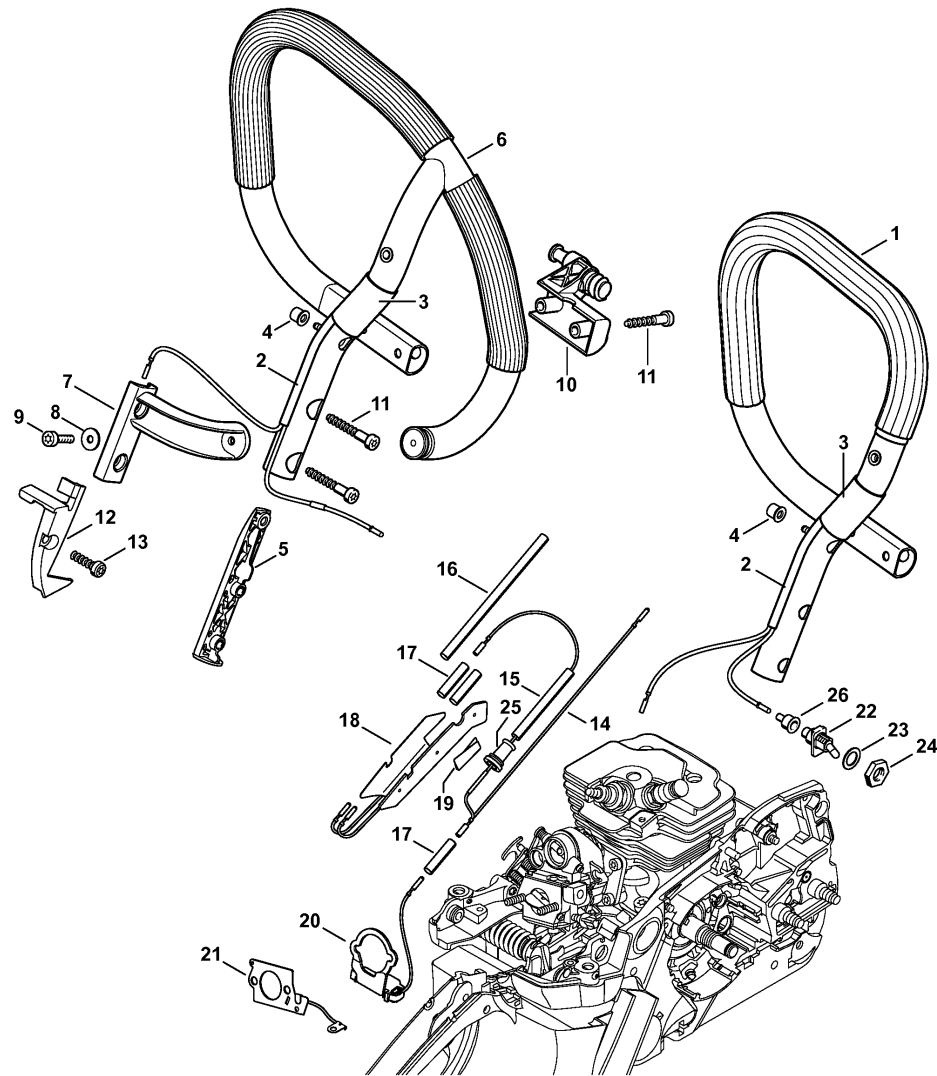

0001ET021 SC

Reference	Item number	Qty	Description
1	1140 790 1700	1	Handlebar (5-6) □ 2 - 5
2	0000 937 4047	1	Hose 205 mm (4-6)
3	0000 937 4048	1	Hose (4-6)
4	0000 791 7900	1	Bushing (4-6)
5	1140 791 5100	1	Stiffener (4-6)
6	1140 790 3701	1	Wrap around handlebar with hose (4) □ 2 - 5
7	1140 791 5500	1	Elbow connector (4)
8	9307 021 0120	1	Washer 5.3 (4)
9	9022 371 1020	1	Spline screw IS-M5x20 (4)
10	1140 791 1900	1	Handlebar support (4-6)
11	9074 478 4705	4	Pan head self-tapping screw IS-P6x40 (4-6)
12	1140 791 7500	1	Cover (4-6)
13	9074 478 4475	1	Pan head self-tapping screw IS-P6x21.5 (4-6)
14	1140 440 3001	1	Wiring harness (4-6)
15	0000 937 4062	1	Hose 60 mm (4-6)
16	0000 937 4063	1	Hose 110 mm (4-6)
17	1121 442 0402	3	Insulating hose 35 mm / 1.4" (4-6)
18	1140 430 6004	1	Heating element (4-6) □ 19
19	1140 431 0200	1	Clip (4-6)
20	1140 430 0600	1	Switch (4-6)
21	1140 434 5100	1	Heating element (4-6)
22	1138 430 0502	1	Switch (4-6)
23	0000 958 1511	1	Washer (4-6)
24	1128 432 2200	1	Hexagon nut (4-6)
25	1125 162 2901	1	Grommet (4-6)
26	1110 432 9200	1	Grommet (4-6)

(1) MS 362, (2) MS 362-Z, (3) MS 362-RZ, (4) MS 362-RVWZ, (5) MS 362-VVW, (6) MS 362-VWZ, (7) MS 362 C-B, (8) MS 362 C-Q, (9) MS 362 C-Q Z

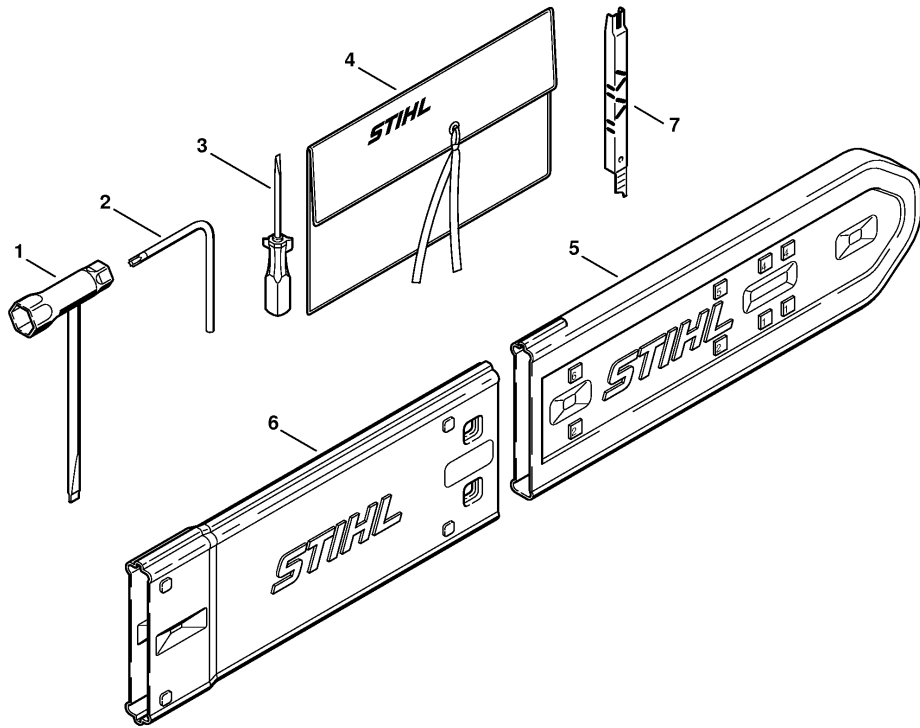

219ET013 TG

Reference	Item number	Qty	Description
	1121 890 1400	1	Tool kit □ 1 - 4
1	1129 890 3401	1	Combination wrench
2	0812 370 1000	1	Screwdriver T27x120x70
3	0000 890 2300	1	Screwdriver
4	0000 891 0810	1	Tool roll
5	0000 792 9129	1	Chain scabbard
6	0000 792 9132	1	Chain scabbard extension up to 63 cm (B)
7	1110 893 4000	1	Filing gauge (B)

(1) MS 362, (2) MS 362-Z, (3) MS 362-RZ, (4) MS 362-RVWZ, (5) MS 362-VW, (6) MS 362-VWZ,
(7) MS 362 C-B, (8) MS 362 C-Q, (9) MS 362 C-Q Z