

377ET000 SC

Reference	Item number	Qty	Description
1	4224 020 2905	1	Crankcase □ 2 - 4
2	9503 003 0540	1	Grooved ball bearing 6204
3	9640 003 2257	1	Oil seal 20x42x5
4	1122 790 9901	1	Annular buffer 1122/01
5	0000 791 3102	1	Spring
6	4224 792 2902	2	Bearing plug
7	9022 371 1020	1	Spline screw IS-M5x20
8	4224 020 2606	1	Crankcase, fan side □ 9 - 14
9	9503 003 0450	1	Grooved ball bearing 6203
10	9640 003 1745	1	Oil seal 17x28x7
11	1110 122 3900	1	Elbow connector
12	0000 988 8600	2	Sleeve
13	1122 790 9900	1	Annular buffer 1122/00
14	1122 790 9901	1	Annular buffer 1122/01
15	9074 478 4435	3	Pan head self-tapping screw IS-P6x19
16	1122 791 7300	3	Plug
17	4224 030 0400	1	Crankshaft (25.2005) □ 18
18	1120 036 8500	1	Woodruff key 2x3.7
19	4224 029 0500	1	Gasket
20	9022 371 1020	5	Spline screw IS-M5x20
	4224 007 1012	1	Set of gaskets □ 3, 10, 19
*	4224 007 1010	1	Set of gaskets (43.2007) □ 3, 10, 19

(1) TS 800, (2) TS 800-Z

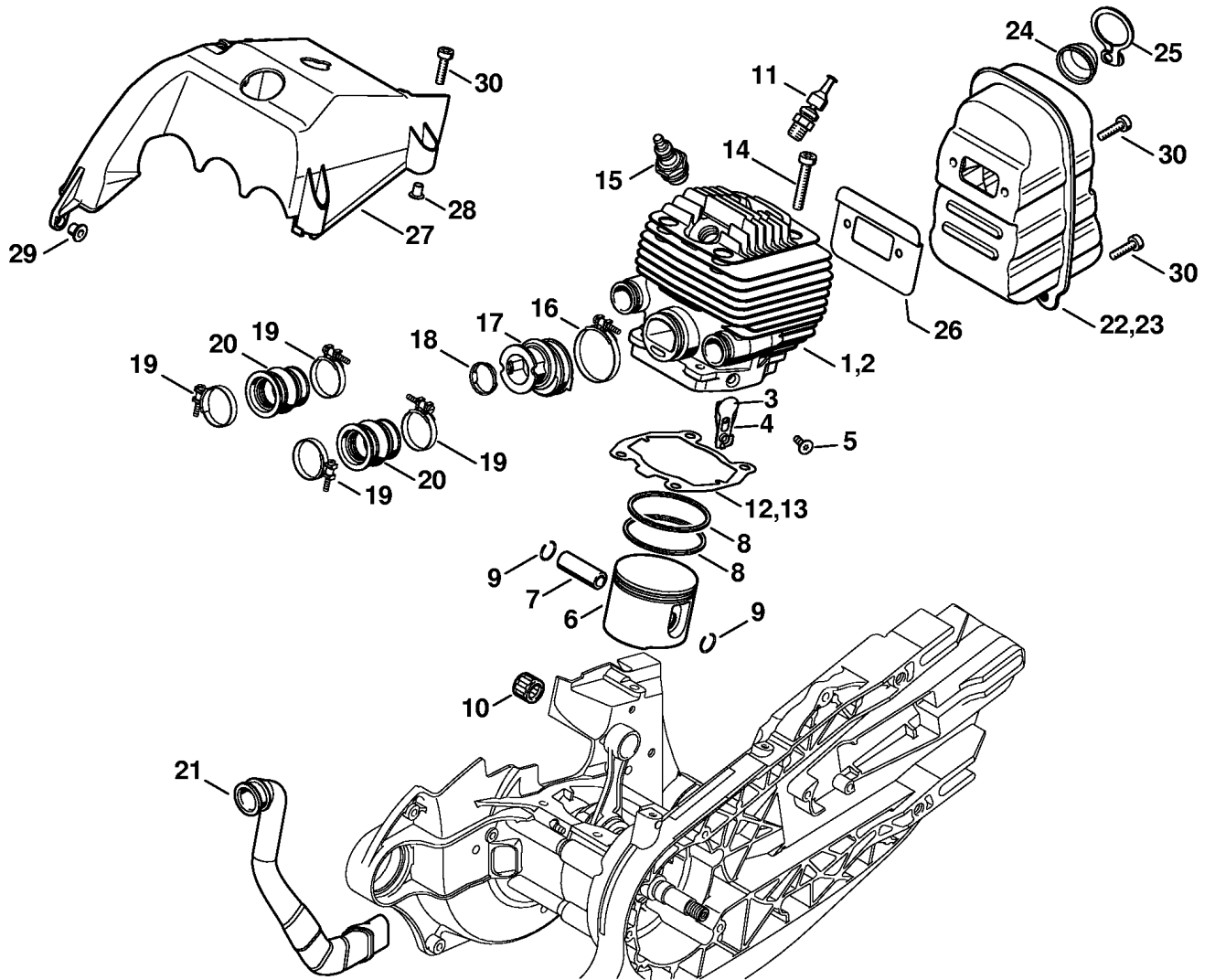

377ET015 SC

Reference	Item number	Qty	Description
1	4224 020 1205	1	Cylinder with piston Ø 56 mm □ 3 - 9
2	* 4224 020 1202	1	Cylinder with piston Ø 56 mm (43.2007) □ 3 - 9
	4224 020 1601	4	Diaphragm □ 3 - 5
	* 4224 020 1600	4	Diaphragm (43.2007) □ 3 - 5
3		1	Diaphragm (D)
4		1	Support plate (D)
5		1	Screw (D)
6	4224 030 2005	1	Piston Ø 56 mm □ 7 - 9
7	4224 034 1500	1	Piston pin 12x8x35
8	1115 034 3013	2	Piston ring Ø 56x1.5 mm
9	9463 650 1200	1	Snap ring 12x1
10	9512 003 3283	1	Needle cage 12x17x13
11	4223 020 9400	1	Decompression valve
12	4224 029 2302	1	Cylinder gasket
13	* 4224 029 2300	1	Cylinder gasket (43.2007)
14	9022 341 1380	4	Spline screw IS-M6x35
15	0000 400 7000	1	Spark plug NGK BPMR7A
15	1110 400 7005	1	Spark plug Bosch WSR 6 F
16	9771 021 2620	1	Hose clip Ø 36x5
17	4223 141 2200	1	Manifold
18	1122 141 1805	1	Sleeve
19	9771 021 2524	4	Hose clip 28x5
20	4224 141 2202	2	Manifold
21	4224 141 5400	1	Hose

(1) TS 800, (2) TS 800-Z

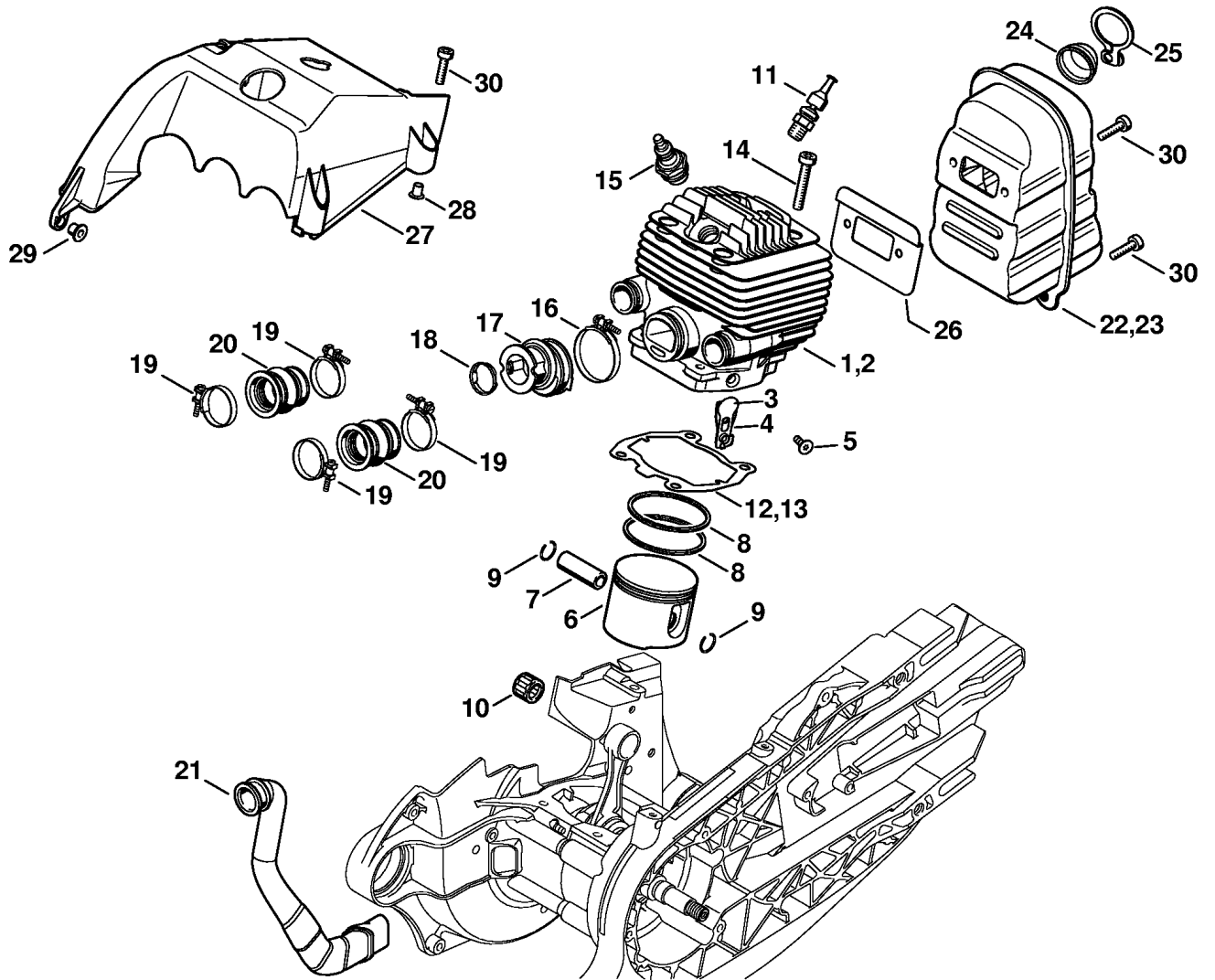

377ET015 SC

Reference	Item number	Qty	Description
22	4224 140 0601	1	Muffler (1) □ 26, 30
23	4224 140 0602	1	Muffler (2) USA, AUS, CDN □ 24 - 26, 30
24	4224 141 9000	1	Screen (2) USA, AUS, CDN
25	4224 141 6601	1	Clip (2) USA, AUS, CDN
26	4224 149 0600	1	Muffler gasket
27	4224 080 0900	1	Air guide shroud □ 28, 29
28	9416 868 6531	1	Hollow rivet 6.5x0.5x6.8
29	9991 003 5087	1	Sleeve 7.5x6.8
30	9022 371 1020	5	Spline screw IS-M5x20
	4224 007 1012	1	Set of gaskets □ 12, 26
*	4224 007 1010	1	Set of gaskets (43.2007) □ 13, 26

(1) TS 800, (2) TS 800-Z

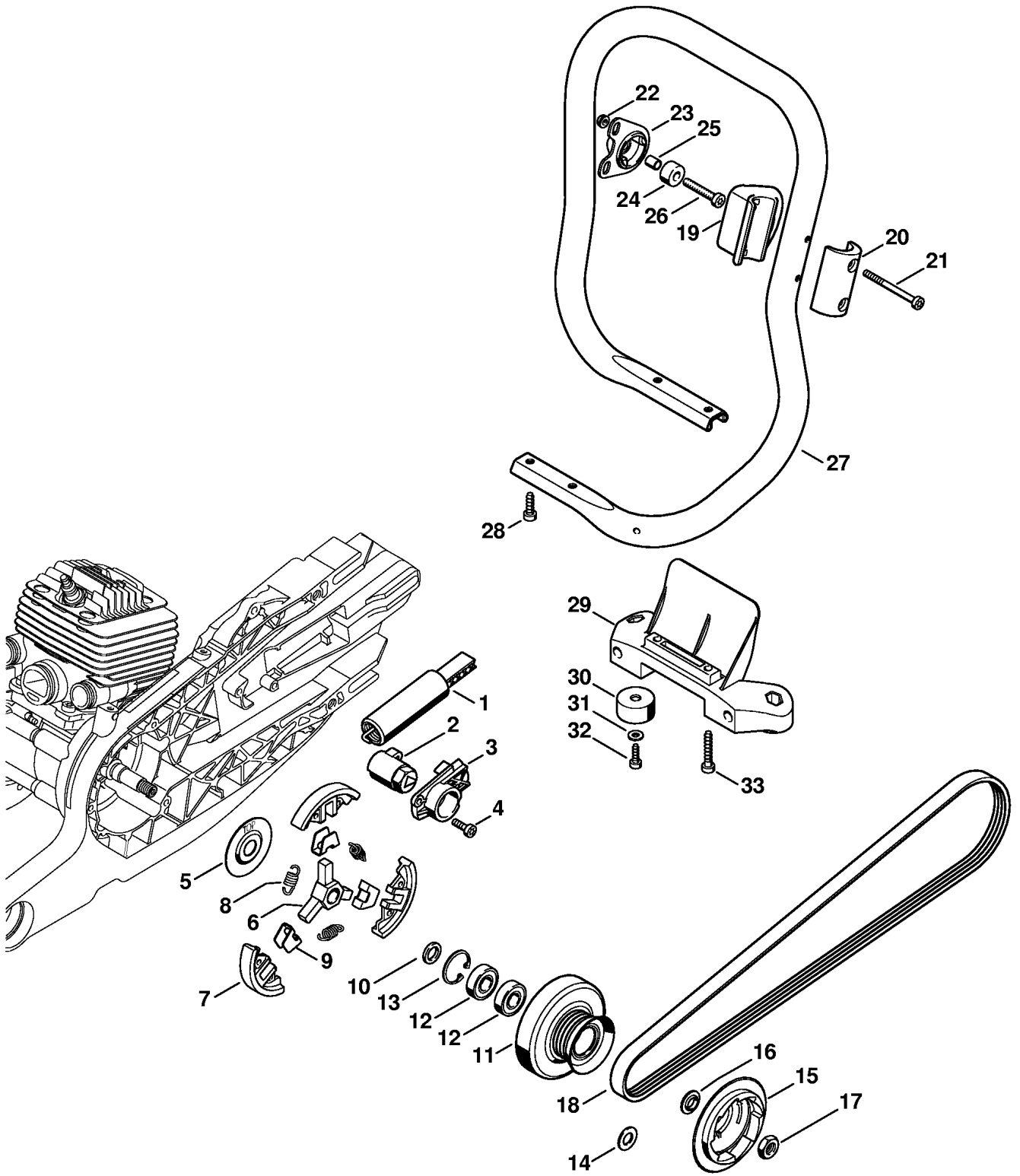

377ET022 SC

Reference	Item number	Qty	Description
1	4221 660 0400	1	Belt tensioner
2	4224 664 2100	1	Clamping lever
3	4224 664 4200	1	Cover
4	9022 341 0980	2	Spline screw IS-M5x16
5	4221 162 1000	1	Cover washer
6	4224 160 2001	1	Clutch □ 7 - 9
7	1122 162 0800	3	Clutch shoe
8	0000 997 5503	3	Tension spring
9	1122 162 3005	3	Retainer
10	4224 162 2600	1	Spacer ring
11	4224 760 8500	1	Poly V-belt pulley □ 12, 13
12	9503 003 5136	2	Grooved ball bearing 6001-2RS
13	9456 621 3100	1	Circlip 28x1.2
14	* 9291 021 3870	1	Washer 10.5x20x1.5 (26.2008)
15	4224 190 0550	1	Starter cup □ 16
16	4224 195 0200	1	Sleeve
17	9211 260 1340	1	Hexagon nut M10x1
18	9490 000 7915	1	Poly V-belt, ribbed 4PK998LB
19	4224 791 1900	1	Handlebar support
20	4224 791 0900	1	Clamp
21	9022 341 1120	2	Spline screw IS-M5x58
22	9216 261 0700	2	Hexagon nut M5
23	4224 790 9904	1	Annular buffer
24	4224 703 4300	1	Stop buffer
25	4224 703 3800	1	Sleeve
26	9022 341 1380	1	Spline screw IS-M6x35
27	4224 791 1704	1	Handlebar
28	9074 478 4435	2	Pan head self-tapping screw IS-P6x19
	4224 790 7601	1	Support □ 29 - 32
29	4224 791 7602	1	Support
30	4205 790 9300	2	Rubber buffer
31	0000 958 0511	2	Washer
32	9075 478 4115	2	Pan head self-tapping screw IS-D5x16
33	9074 478 4675	2	Pan head self-tapping screw IS-P6x32.5

(1) TS 800, (2) TS 800-Z

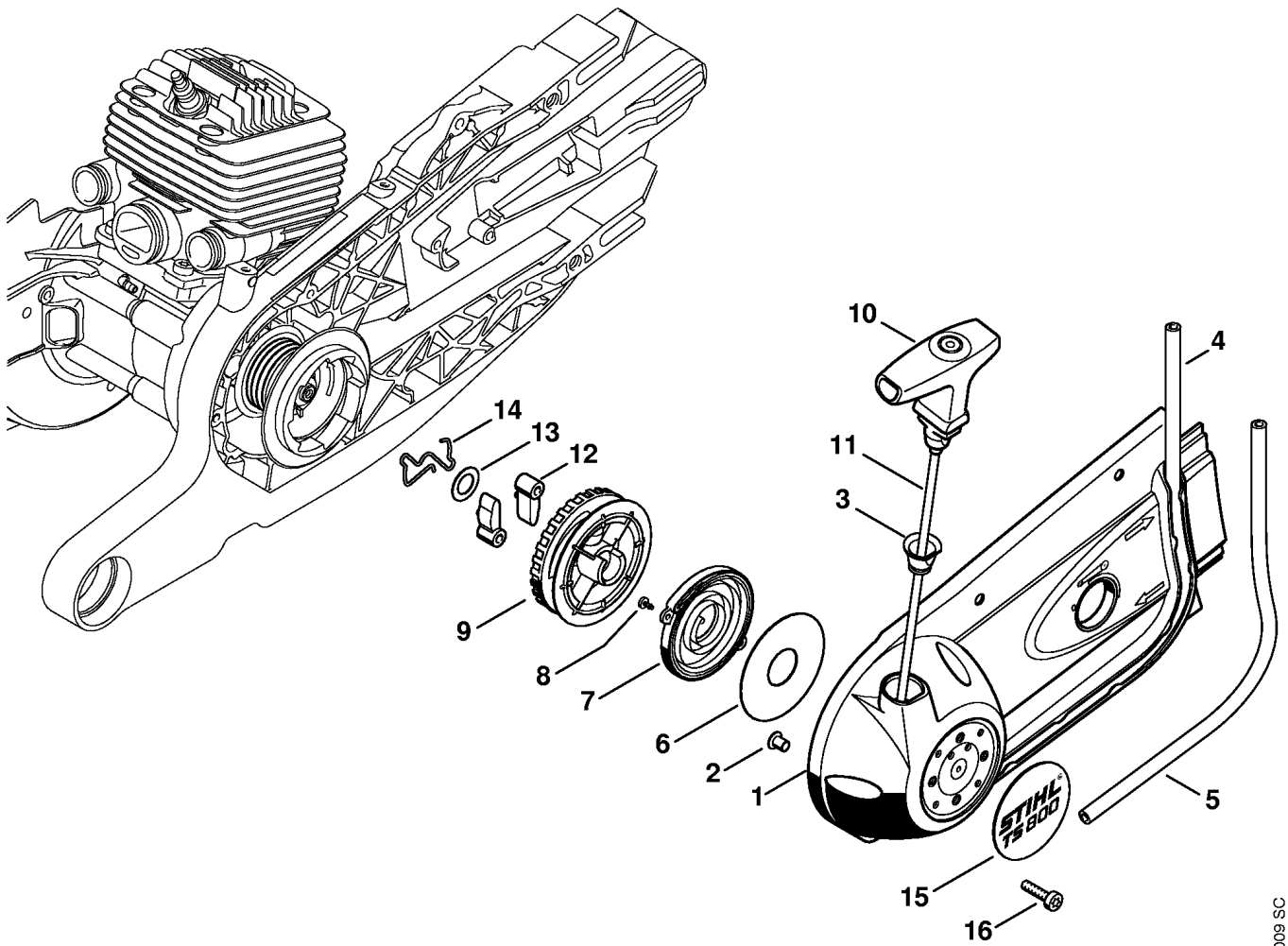

377ET009 SC

Reference	Item number	Qty	Description
	4224 190 0305	1	Starter cover with rewind starter □ 1 - 4, 6 - 15
1	4224 190 0411	1	Starter cover □ 2 - 4, 15
2	9443 825 7130	3	Hollow rivet 7.5x1x6.8
3	1110 084 9102	1	Bushing
4		1	Hose 5.6x1.9x674 mm (D)
	0000 937 4049	1	Hose 5.6x1.9 mm x 1 m (A,B)
5	*	1	Hose 6x1.5x640 mm / 25 3/16" (D) (40.2006)
	* 0000 937 4035	1	Hose 6x1.5 mm x 1 m (A,B) (40.2006)
6	4238 195 9000	1	Washer
7	4224 190 0600	1	Rewind spring
8	9104 003 0410	2	Self-tapping screw P3x6
9	4221 190 1000	1	Rope rotor
10	0000 190 3414	1	Starter grip ElastoStart Ø 4.5 mm □ 11
11	0000 190 2901	1	Starter rope Ø 4.5 mm
	0000 930 2295	1	Starter rope Ø 4.5mm / 28 pieces (A,B)
12	4221 195 7200	2	Pawl
13	1119 162 8925	1	Washer Ø 12 mm
14	4224 195 3500	1	Spring
15	4224 967 1501	1	Model plate TS 800
16	9022 371 1020	3	Spline screw IS-M5x20

(1) TS 800, (2) TS 800-Z

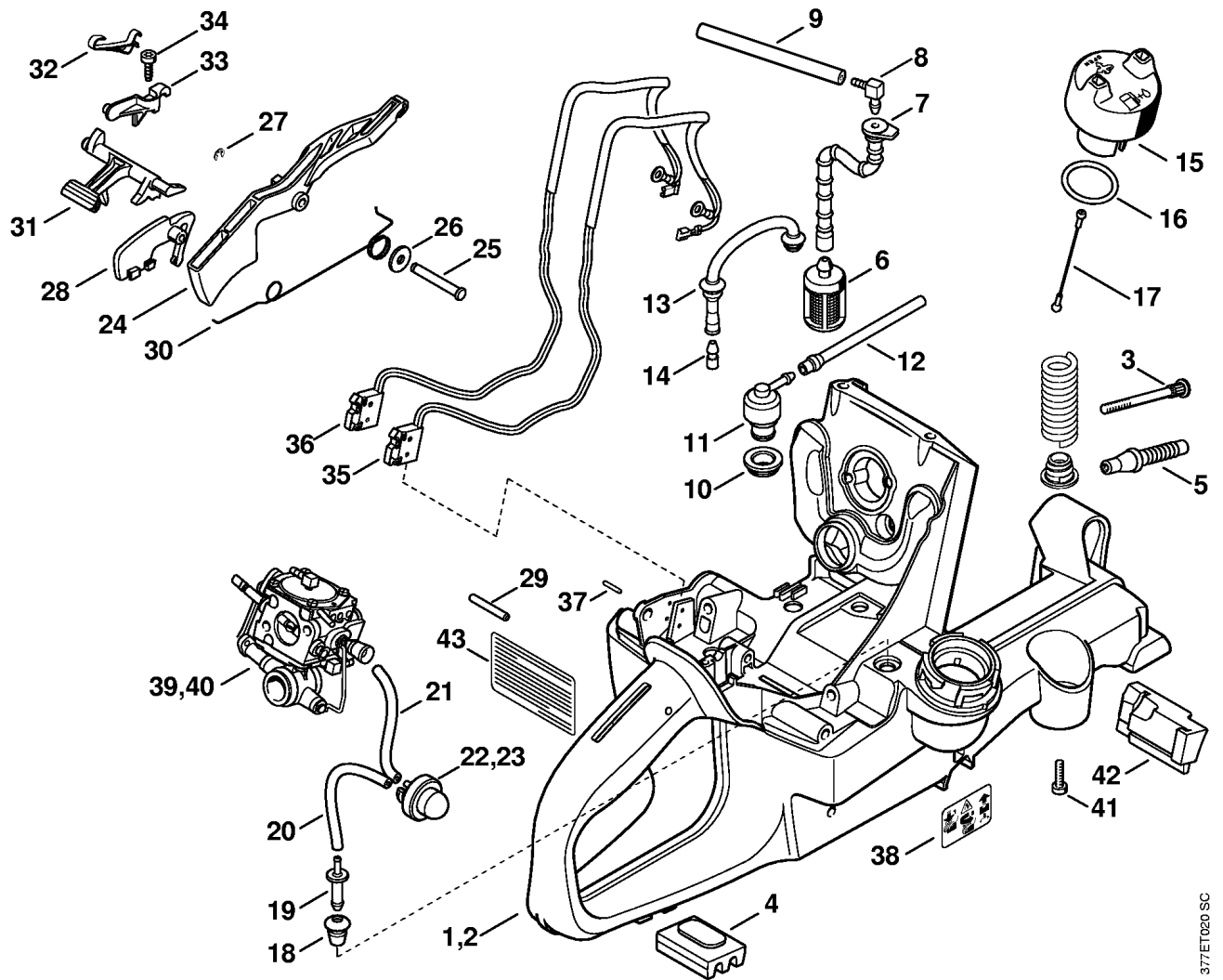

377ET020 SC

Reference	Item number	Qty	Description
1	4224 350 0812	1	Tank housing □ 3 - 20, 24 - 35, 37, 38
2	* 4224 350 0814	1	Tank housing (43.2007) □ 3 - 20, 24 - 34, 36 - 38
3	1122 122 6602	2	Collar screw
4	4221 792 9300	1	Rubber buffer
5	4223 141 8600	1	Impulse hose
6	0000 350 3504	1	Pickup body
7	1124 358 7700	1	Hose
8	4224 122 3900	1	Elbow connector
9		1	Hose 3.1x5.7x93 mm (D)
	0000 930 2803	1	Hose 3.1x5.7 mm x 1 m (A,B)
10	4223 353 9201	1	Grommet
11	4238 350 5800	1	Tank vent
12		1	Hose 3.1x5.7x93 mm (D)
	0000 930 2803	1	Hose 3.1x5.7 mm x 1 m (A,B)
13	4224 350 5801	1	Tank vent □ 14
14	4224 358 8100	1	Vent insert
15	0000 350 0502	1	Filler cap □ 16, 17
16	9645 948 2470	1	O-ring 23x3
17	0000 350 0905	1	Rope
18	0000 989 0608	1	Grommet
19	0000 988 5206	1	Connector
20		1	Hose 2.2x5.4x128 mm (D)
21		1	Hose 2.2x5.4x73 mm (D)
	0000 930 2802	1	Hose 2.2x5.4 mm x 1 m (A,B)
22	0000 350 6202	1	Fuel pump
23	* 1130 350 6200	1	Fuel pump (61.2007)
24	4224 182 1000	1	Throttle trigger
25	4224 182 8900	1	Pin
26	0000 958 0526	1	Washer
27	9460 624 0320	1	E-clip 3.2
28	4224 182 0800	1	Trigger interlock
29	9381 003 2180	1	Cylindrical pin 4x28
30	4224 182 4500	1	Torsion spring

(1) TS 800, (2) TS 800-Z

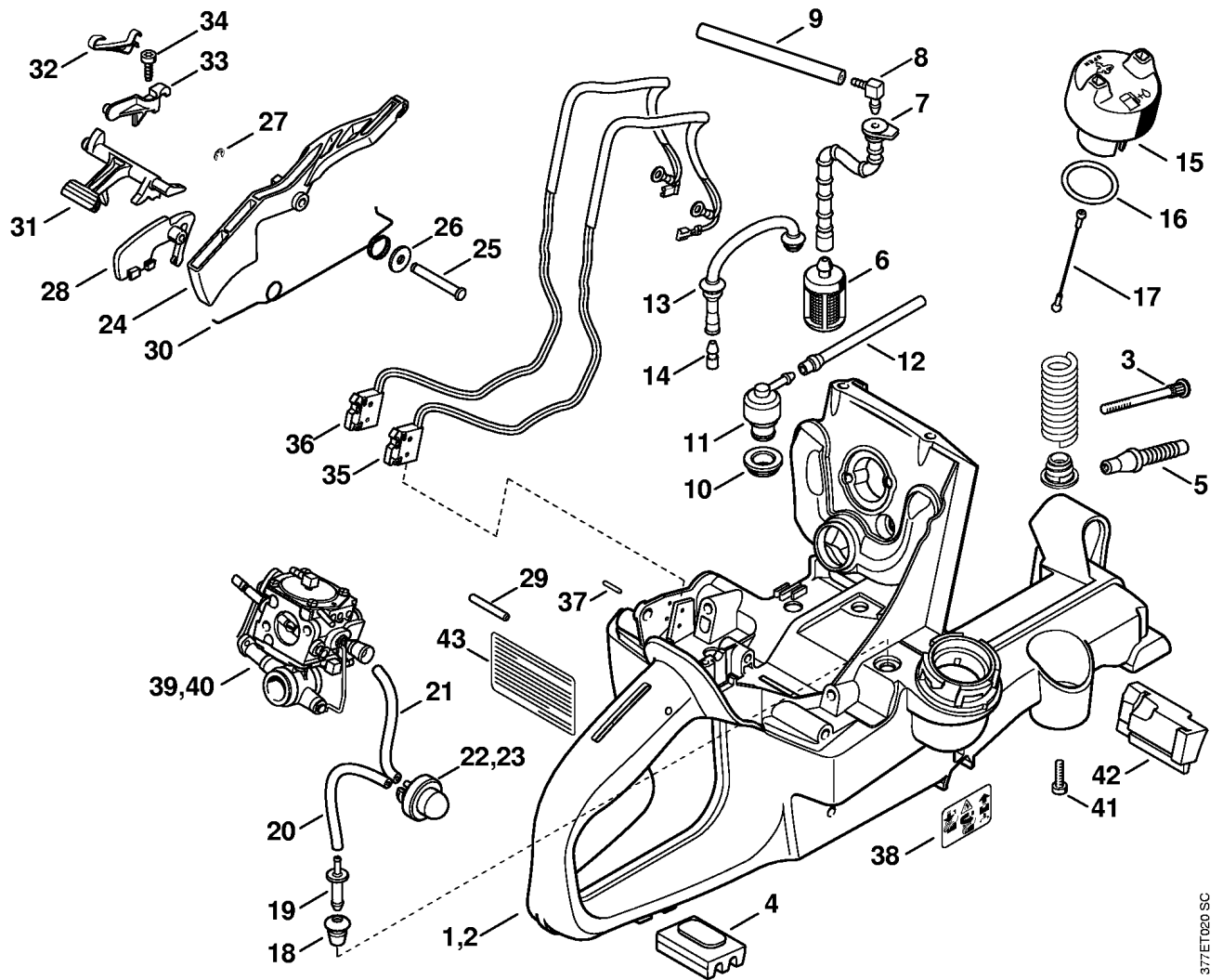

377ET020 SC

Reference	Item number	Qty	Description
31	4224 182 0900	1	Switch shaft
32	4224 182 4700	1	Flat spring
33	4224 182 4400	1	Bearing
34	9074 478 3005	1	Pan head self-tapping screw IS-P4x14
35	4224 430 0503	1	Switch
36	* 4224 430 0501	1	Switch (43.2007)
37	9381 651 1200	2	Cylindrical pin 6x13
38	0000 967 3768	1	Warning pictogram Filler cap
39	4224 120 0601	1	Carburetor WJ-114
40	* 4224 120 0600	1	Carburetor HS-314A (43.2007)
41	9022 341 1019	1	Spline screw IS-M5x20
42	4224 791 5901	1	Stop buffer
43	0000 967 3502	1	Instruction label (2) USA, CDN

(1) TS 800, (2) TS 800-Z

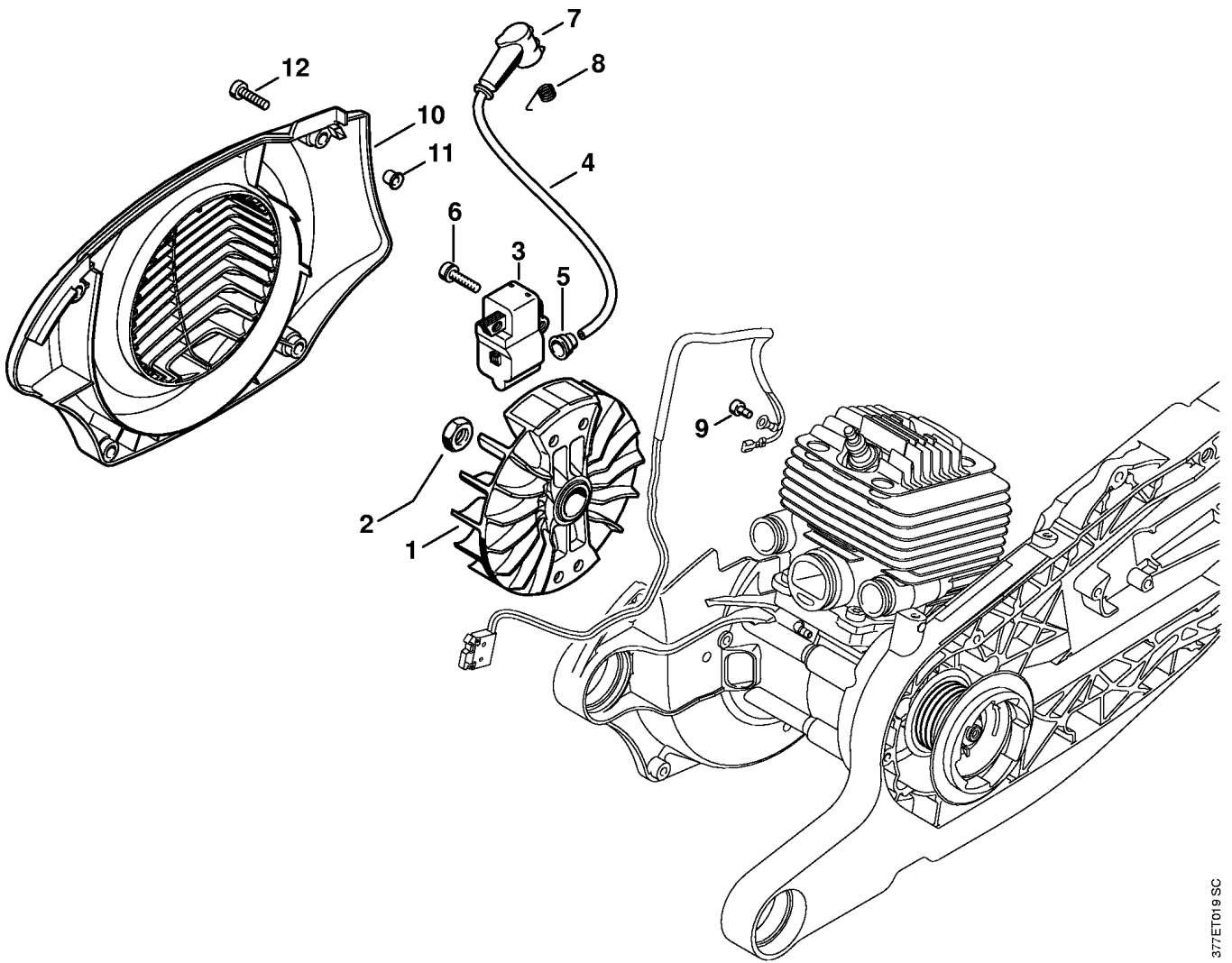

377E1019 SC

Reference	Item number	Qty	Description
1	4224 400 1201	1	Flywheel (25.2005)
2	9211 260 1340	1	Hexagon nut M10x1
3	4224 400 1301	1	Ignition module □ 4, 5
4		1	Ignition lead 335 mm (D)
	0000 405 0600	1	Ignition lead 1 m (A,B)
	0000 930 2251	1	Ignition lead 10 m (A,B)
5	0000 989 1002	1	Grommet
6	9022 341 1019	2	Spline screw IS-M5x20
7	1128 405 1000	1	Spark plug boot
8	0000 998 0604	1	Torsion spring
9	9022 313 0630	1	Spline screw IS-M4x8
10	4224 080 3100	1	Fan cover □ 11
11	9443 825 7130	3	Hollow rivet 7.5x1x6.8
12	9022 371 1020	4	Spline screw IS-M5x20

(1) TS 800, (2) TS 800-Z

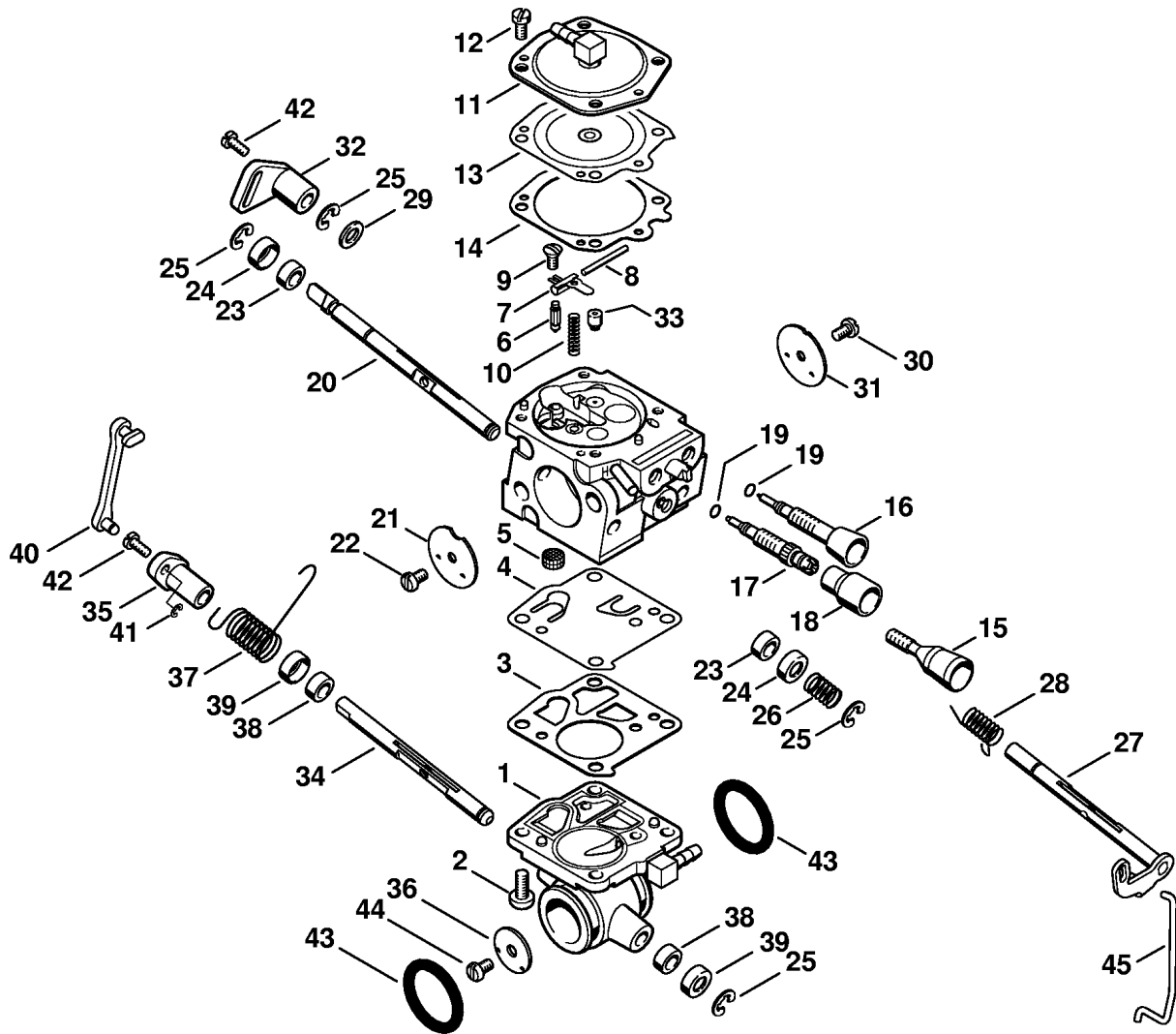

376ET027 SC

Reference	Item number	Qty	Description
	4224 120 0601	1	Carburetor WJ-114 □ 1 - 44
1	4224 121 0803	1	End cover
2	1115 122 7100	4	Round head screw
3	1115 129 1100	1	Gasket
4	1115 121 4800	1	Pump diaphragm
5	1114 121 7800	1	Strainer
6	1110 121 5100	1	Inlet needle
7	1117 121 5000	1	Inlet control lever
8	1117 121 9200	1	Spindle
9	1114 122 7400	1	Round head screw
10	4224 122 3000	1	Spring
11	4224 121 0804	1	End cover
12	1106 122 7400	4	Round head screw
13	1117 121 4700	1	Metering diaphragm
14	1116 129 0900	1	Gasket
15	4224 122 6201	1	Idle speed adjustment screw
16	4224 122 6801	1	Low speed adjustment screw □ 19
17	4224 122 6701	1	High speed adjustment screw □ 19
18	4224 121 2701	1	Cap
19		1	Sealing ring (D)
20	4224 121 3001	1	Choke shaft
21	4224 121 2901	1	Choke shutter
22	1121 122 7102	2	Round head screw
23	4224 122 3602	2	Sealing ring
24	4223 121 9400	2	Ring
25	1117 122 9000	4	E-clip
26	4223 122 3001	1	Spring
27	4224 120 7103	1	Throttle shaft with lever
28	4224 122 3203	1	Torsion spring
29	1115 121 8600	1	Washer
30	1115 122 7400	1	Round head screw
31	4224 121 3301	1	Throttle shutter
32	4224 121 6604	1	Lever
33	1128 121 5605	1	Fixed jet 0.66
34	4224 126 0201	1	Air valve shaft
35	4224 121 6603	1	Lever
36	4224 126 0301	1	Air valve

(1) TS 800, (2) TS 800-Z

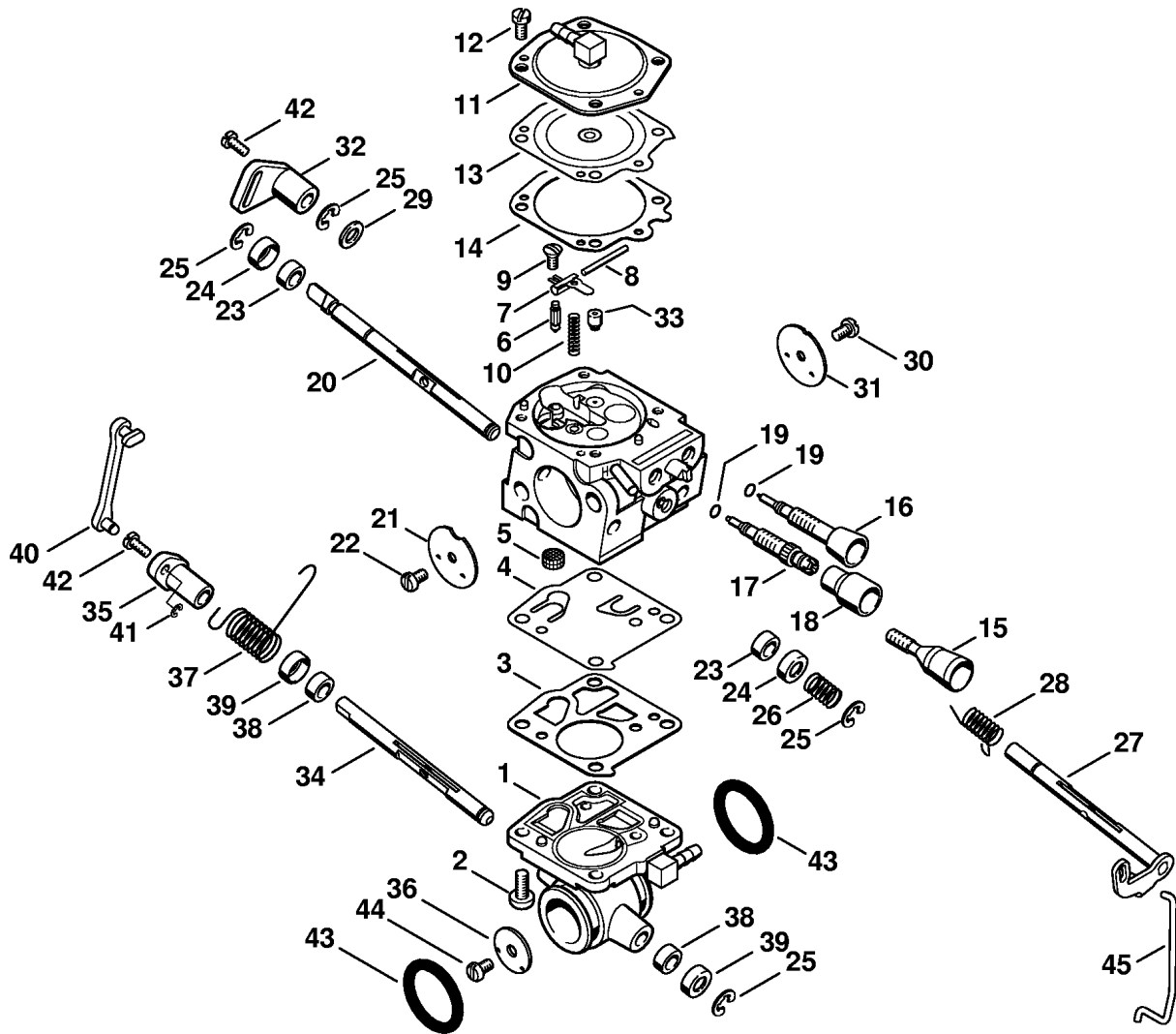

376ET027 SC

Reference	Item number	Qty	Description
37	4224 122 3202	1	Torsion spring
38	4224 122 3602	2	Sealing ring
39	4224 121 9400	2	Ring
40	4224 124 2101	1	Rod
41	4224 122 9004	1	E-clip
42	4224 122 7100	2	Screw
43	9645 945 7574	2	O-ring 17x3
44	4224 122 7801	1	Oval head screw
45	4224 182 1500	1	Throttle rod
	1122 007 1060	1	Set of carburetor parts □ 3, 4, 13, 14

(1) TS 800, (2) TS 800-Z

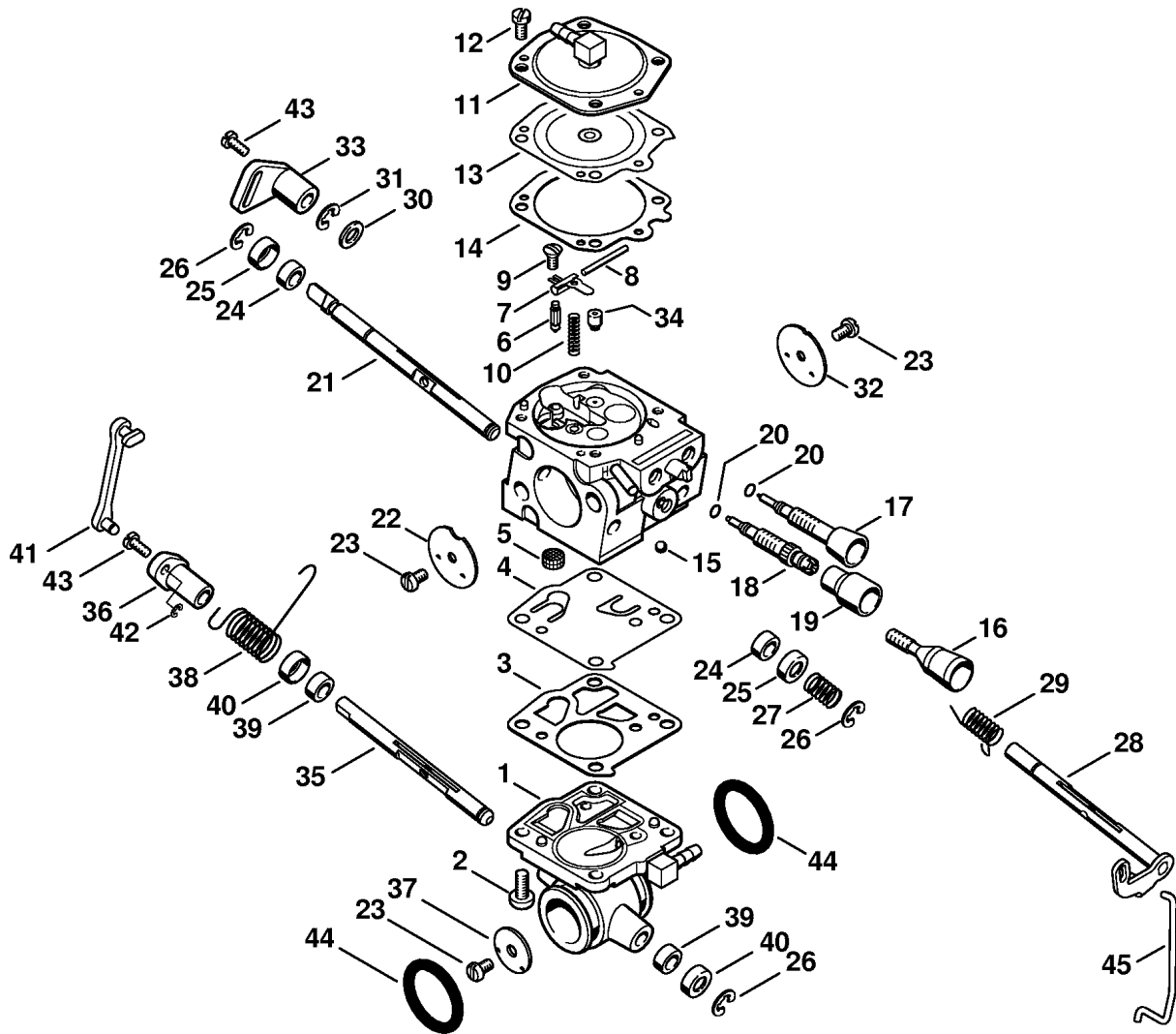

376ET010 SC

Reference	Item number	Qty	Description
	* 4224 120 0600	1	Carburetor HS-314A (43.2007) □ 1 - 44
1	* 4224 121 0800	1	End cover (43.2007)
2	* 1106 122 7400	4	Round head screw (43.2007)
3	* 1110 129 1110	1	Gasket (43.2007)
4	* 1124 121 4800	1	Pump diaphragm (43.2007)
5	* 4221 121 7800	1	Strainer (43.2007)
6	* 4116 121 5100	1	Inlet needle (43.2007)
7	* 1124 121 5000	1	Inlet control lever (43.2007)
8	* 1110 121 9200	1	Spindle (43.2007)
9	* 1110 122 7801	1	Oval head screw (43.2007)
10	* 1124 122 3000	1	Spring (43.2007)
11	* 4224 121 0802	1	End cover (43.2007)
12	* 1106 122 7400	4	Round head screw (43.2007)
13	* 1110 121 4700	1	Metering diaphragm (43.2007)
14	* 1110 129 0900	1	Gasket (43.2007)
15	* 4221 122 4200	1	Ball (43.2007)
16	* 4224 122 6200	1	Idle speed adjustment screw (43.2007)
17	* 4224 122 6800	1	Low speed adjustment screw (43.2007) □ 20
18	* 4224 122 6700	1	High speed adjustment screw (43.2007) □ 20
19	* 4229 121 2700	1	Cap (43.2007)
20	*	1	Sealing ring (D) (43.2007)
21	* 4224 121 3000	1	Choke shaft (43.2007)
22	* 4224 121 2900	1	Choke shutter (43.2007)
23	* 1110 122 7400	3	Round head screw (43.2007)
24	* 4221 122 3605	2	Sealing ring (43.2007)
25	* 4221 121 9400	2	Ring (43.2007)
26	* 1110 122 9005	3	E-clip (43.2007)
27	* 4223 122 3000	1	Spring (43.2007)
28	* 4224 120 7102	1	Throttle shaft with lever (43.2007)
29	* 4224 122 3200	1	Torsion spring (43.2007)
30	* 4221 121 8600	1	Washer (43.2007)
31	* 1110 122 9005	1	E-clip (43.2007)
32	* 4224 121 3300	1	Throttle shutter (43.2007)
33	* 4224 121 6601	1	Lever (43.2007)
34	* 4224 126 0100	1	Semi-fixed jet (43.2007)
35	* 4224 126 0200	1	Air valve shaft (43.2007)
36	* 4224 121 6602	1	Lever (43.2007)
37	* 4224 126 0300	1	Air valve (43.2007)

(1) TS 800, (2) TS 800-Z

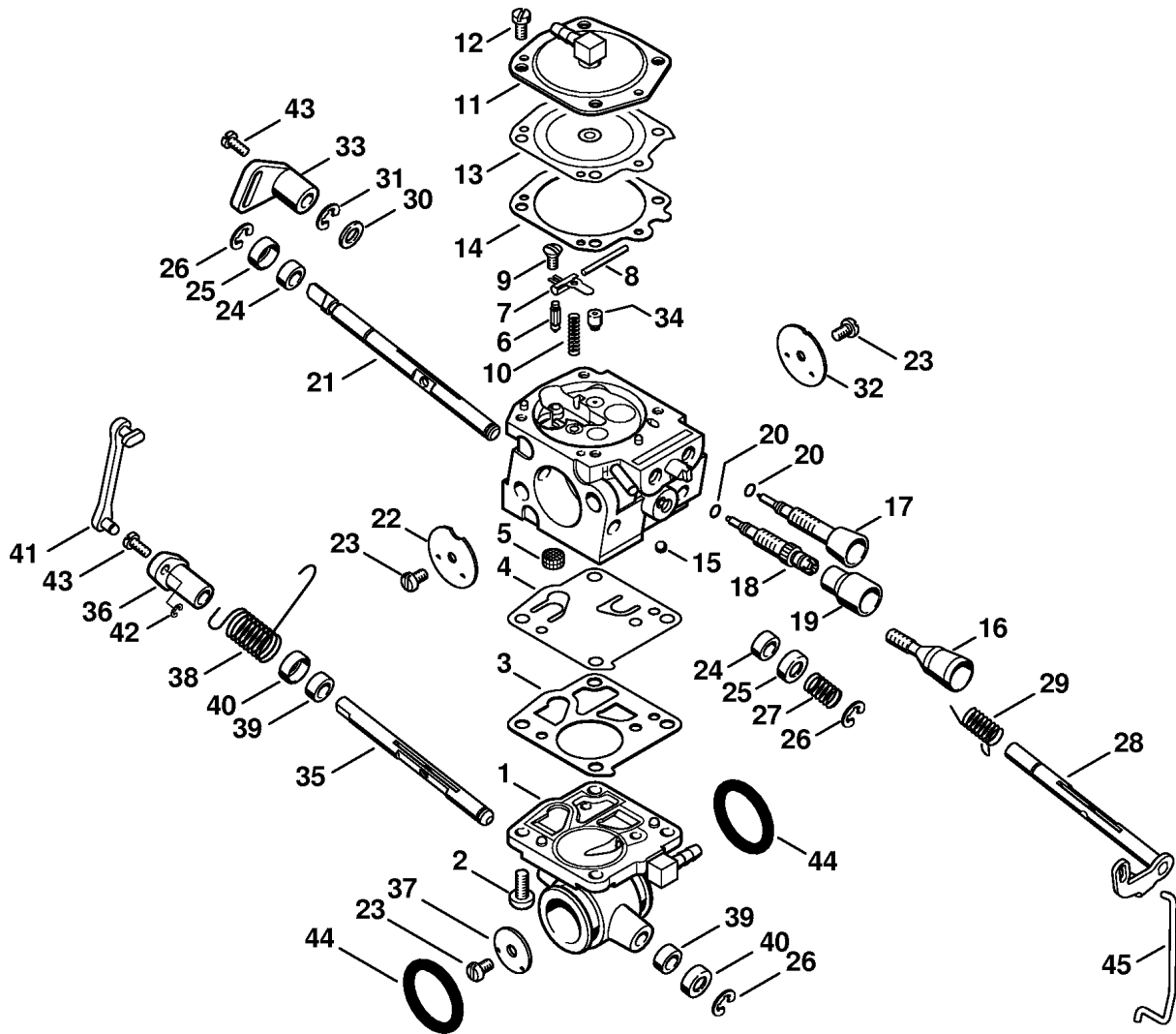

376ET010 SC

Reference	Item number	Qty	Description
38	* 4224 122 3201	1	Torsion spring (43.2007)
39	* 4221 122 3605	2	Sealing ring (43.2007)
40	* 4221 121 9400	2	Ring (43.2007)
41	* 4224 124 2100	1	Rod (43.2007)
42	* 4224 122 9000	1	E-clip (43.2007)
43	* 4221 122 7100	2	Screw (43.2007)
44	* 9645 945 7574	2	O-ring 17x3 (43.2007)
45	* 4224 182 1500	1	Throttle rod (43.2007)
	* 4224 007 1008	1	Set of carburetor parts (43.2007) □ 3, 4, 13, 14, 44

(1) TS 800, (2) TS 800-Z

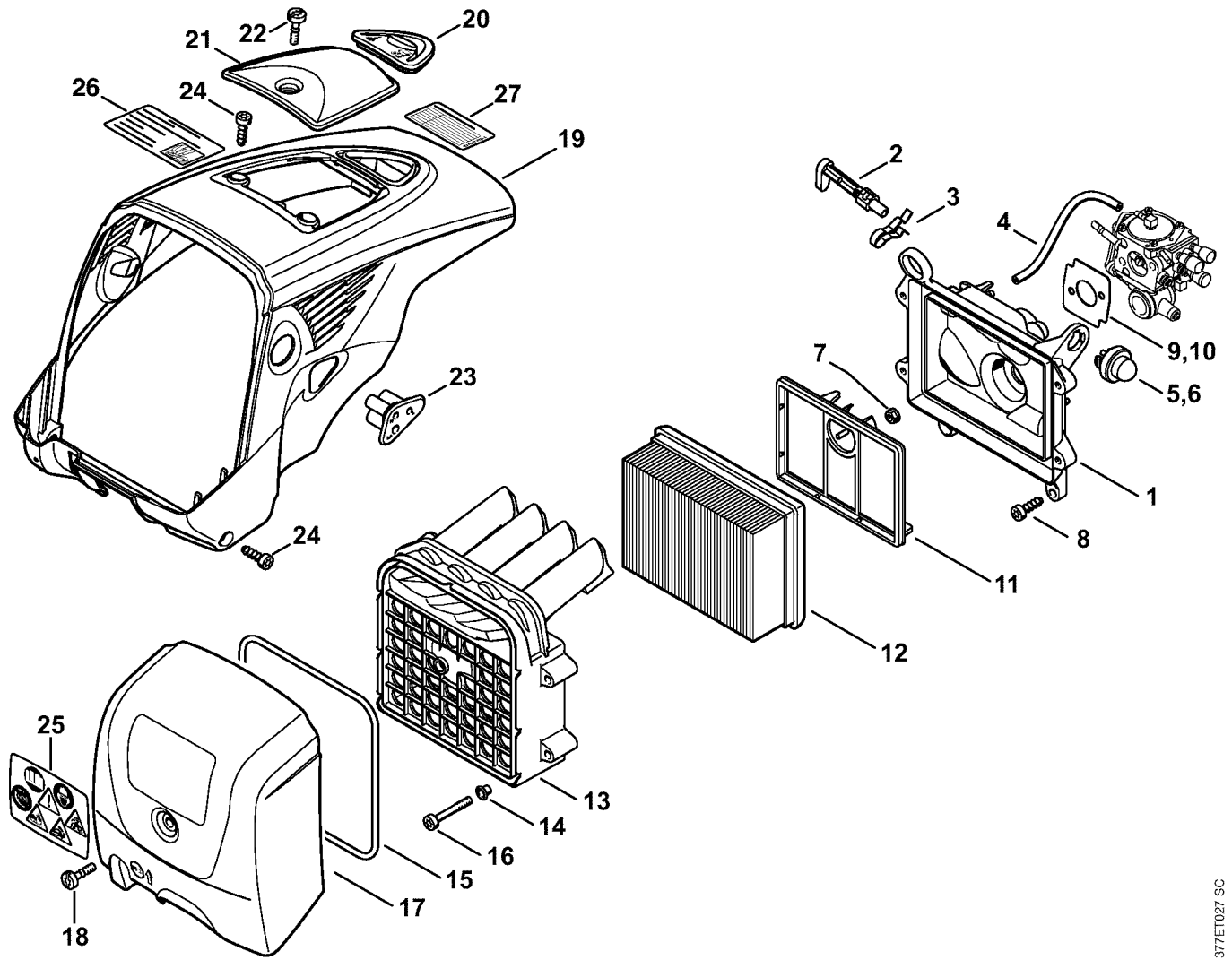

377/ET027 SC

Reference	Item number	Qty	Description
1	4224 140 1204	1	Filter base □ 5
2	4224 121 6100	1	Choke lever
3	4223 121 2400	1	Flat spring
4		1	Hose 3.1x5.7x48 mm (D)
	0000 930 2803	1	Hose 3.1x5.7 mm x 1 m
5	0000 350 6202	1	Fuel pump
6	* 1130 350 6200	1	Fuel pump (61.2007)
7	9216 261 0700	2	Hexagon nut M5
8	9074 478 4435	2	Pan head self-tapping screw IS-P6x19
9	4224 129 0903	1	Gasket
10	* 4224 129 0900	1	Gasket (43.2007)
	4224 007 1013	1	Air filter kit (B) USA □ 11, 12, 15
11	4224 140 1801	1	Auxiliary filter
12	4224 141 0300	1	Air filter
13	4224 140 2800	1	Filter housing □ 14, 15
14	9416 868 6630	4	Hollow rivet 6.5x0.5x6.8
15	4224 149 0500	1	Gasket
16	9022 341 1081	4	Spline screw IS-M5x35
17	4224 140 1000	1	Filter cover □ 18, 25
18	9022 319 1027	1	Screw IS-M5x21
19	4224 080 1600	1	Shroud
20	4224 084 7400	1	Grommet
21	4224 080 2200	1	Cap □ 22
22	9022 319 1027	1	Screw IS-M5x21
23	4224 123 7500	1	Grommet
24	9074 478 4435	4	Pan head self-tapping screw IS-P6x19
25	0000 967 3759	1	Warning pictogram TS
26	4223 967 3701	1	Instruction label (1) J
27	4224 967 3703	1	Instruction label (1) J
	4224 007 1012	1	Set of gaskets □ 9

(1) TS 800, (2) TS 800-Z

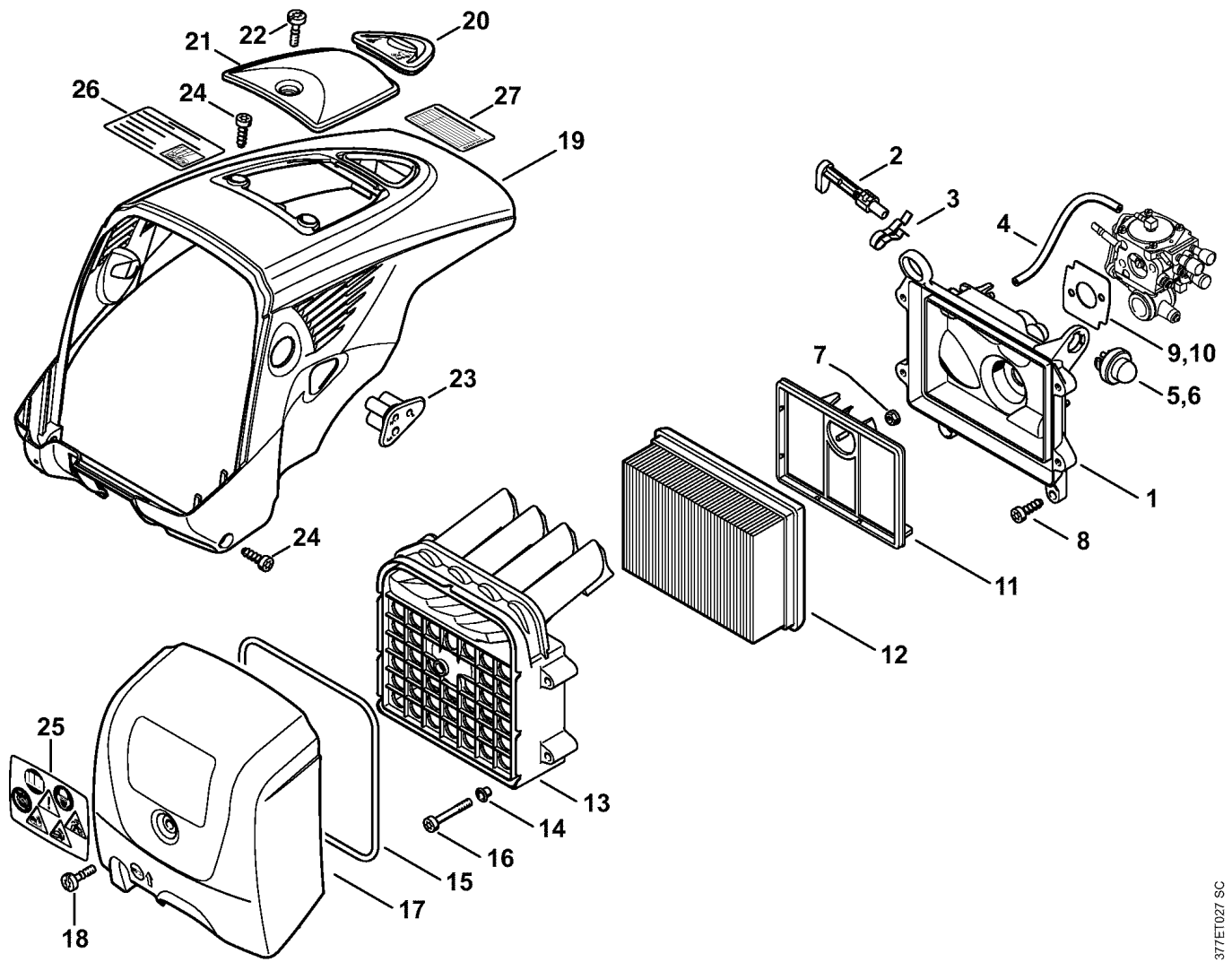

377ET027 SC

Reference	Item number	Qty	Description
*	4224 007 1010	1	Set of gaskets (43.2007) □ 10

(1) TS 800, (2) TS 800-Z

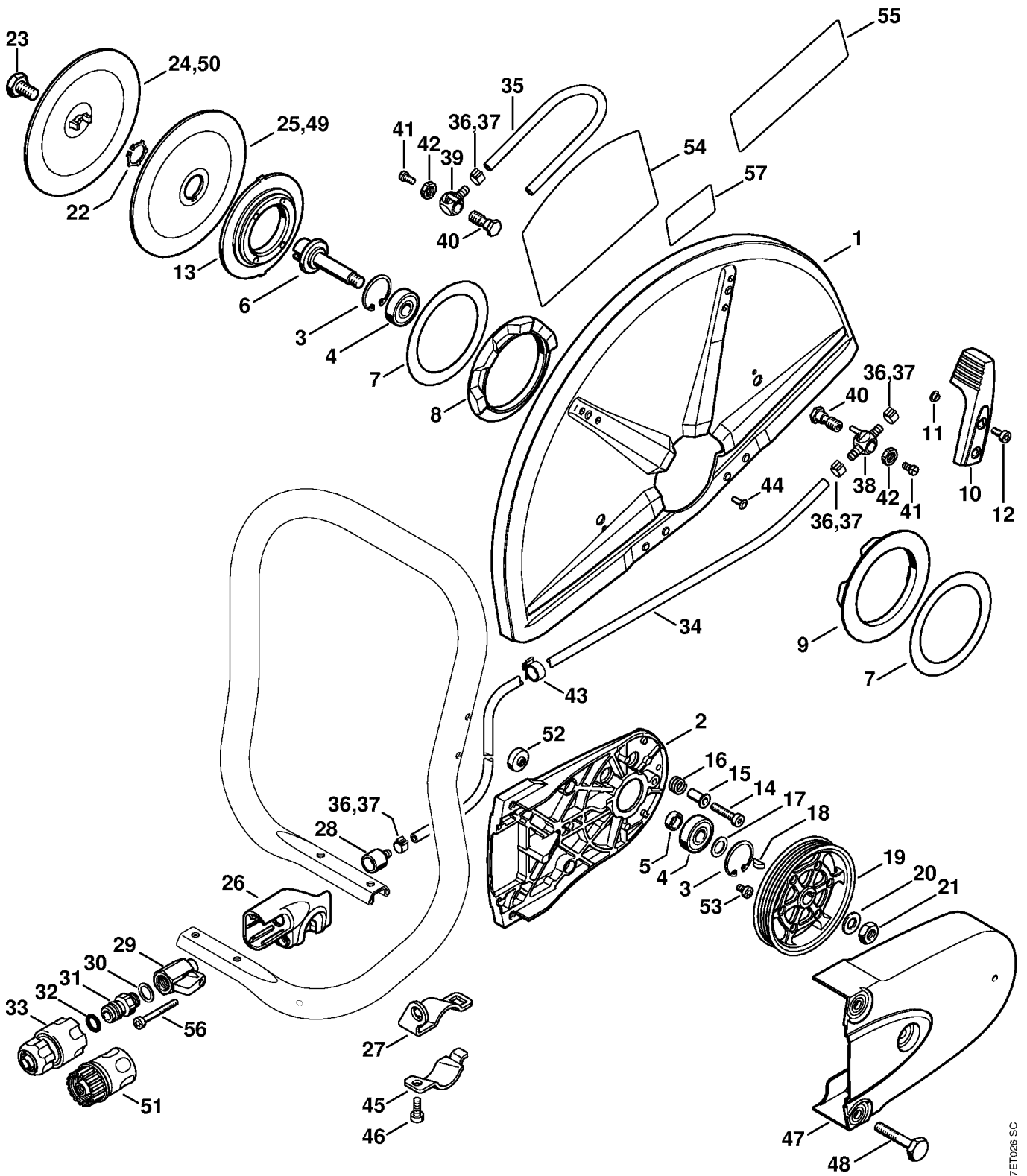

377ET026 SC

Reference	Item number	Qty	Description
	4224 690 0103	1	Support with guard Ø 400 mm / 16" (1) □ 1- 26, 28 - 36, 38 - 44
	4224 690 0104	1	Support with guard Ø 400 mm / 16" (2) USA □ 1- 26, 28 - 32, 34 - 36, 38 - 44, 54
	4224 690 0110	1	Support with guard Ø 400 mm / 16" (2) CDN □ 1- 26, 28 - 32, 34 - 36, 38 - 44, 55
	4224 690 0105	1	Support with guard Ø 400 mm / 16" AUS, J □ 1 - 23, 26, 28 - 36, 38 - 44, 49, 50
1	4224 700 8105	1	Guard Ø 400 mm / 16"
2	4224 791 3901	1	Support
3	9456 621 3600	2	Circlip 32x1.2
4	9503 003 6440	2	Grooved ball bearing 6201-2RS
5	0000 961 1206	1	Ring
6	4201 704 0504	1	Shaft
7	4201 706 9202	2	Washer
8	4221 706 8800	1	Rubber ring
9	4221 706 8801	1	Rubber ring
10	4224 700 2900	1	Adjusting lever □ 11
11	9416 868 6510	2	Hollow rivet 6.5x0.5x3.0
12	9022 341 0960	2	Spline screw IS-M5x12
13	4205 706 2903	1	Flange
14	9022 341 1358	4	Spline screw IS-M6x28
15	4224 704 3200	4	Sleeve
16	0000 997 1303	4	Compression spring
17	0000 958 1212	1	Washer
18	9482 435 0800	1	Woodruff key 4x5
19	4224 764 8502	1	Poly V-belt pulley
20	9291 021 0200	1	Washer 10.5
21	9211 260 1350	1	Hexagon nut M10x1 l/h thread
22	9450 721 2150	1	Circlip 20x1.2
23	4201 708 8402	1	Hexagon head screw M10x18
24	4201 708 3014	1	Thrust washer Ø 103 mm
25	4201 708 3004	1	Thrust washer Ø 103 mm
26	4224 700 6802	1	Bracket

(1) TS 800, (2) TS 800-Z

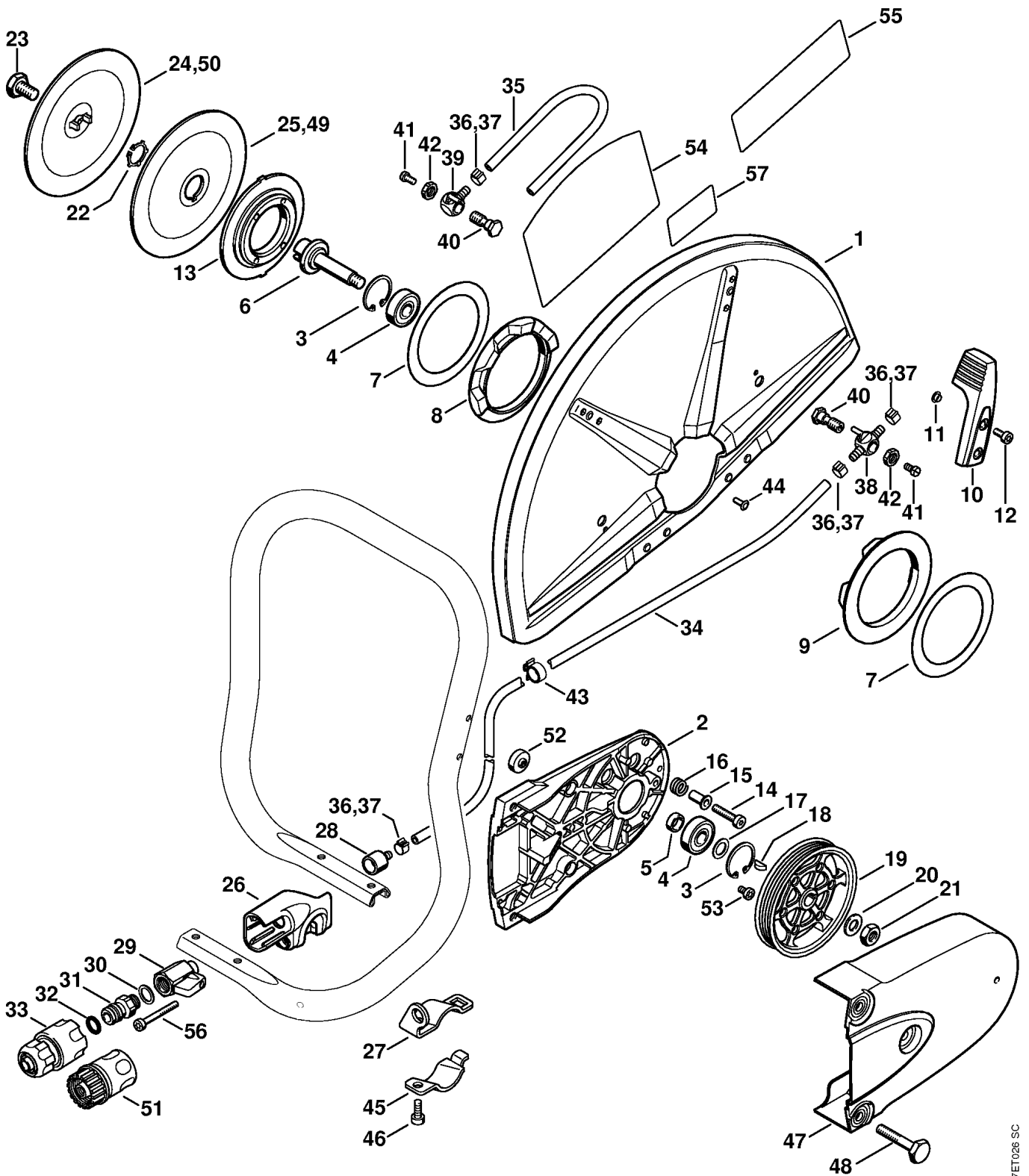

377ET026 SC

Reference	Item number	Qty	Description
27	* 4224 700 6800	1	Bracket (40.2006)
28	4238 677 8200	1	Connector
29	4201 700 4500	1	Shut-off cock 1/4"
30	0000 954 1701	1	Sealing ring
31	4201 700 7300	1	Hose connector □ 32
32	9645 945 7506	1	O-ring 10x3
33	4201 670 1700	1	Coupling sleeve 1/2"
34		1	Hose 5.6x1.9x674 mm (D)
35		1	Hose 5.6x1.9x270 mm / 10 5/8" (D)
	0000 937 4049	1	Hose 5.6x1.9 mm x 1 m (A,B)
36	9771 021 0921	4	Hose clip 10/7
37	* 9771 021 0920	4	Hose clip 9.5/7
38	4224 677 8201	1	Connector
39	4224 677 8202	1	Connector
40	4201 708 8400	2	Banjo bolt
41	9041 216 0950	2	Pan head screw M5x10
42	9211 021 8900	2	Hexagon nut G 1/8"
43	4119 791 9400	1	Cable clamp
44	0000 706 4600	2	Plug
45	* 4224 708 9100	1	Bow (40.2006)
46	* 9022 341 1280	1	Spline screw IS-M6x16 (40.2006)
47	4224 700 8101	1	Guard
48	4224 708 8400	3	Screw
49	4205 708 3001	1	Thrust washer Ø 140 mm AUS, J
50	4205 708 3011	1	Thrust washer Ø 140 mm AUS, J
51	4201 670 1701	1	Coupling sleeve 3/4" (2) USA, CDN
52	4224 790 9300	1	Rubber buffer (2) USA, CDN
53	9022 341 0910	1	Spline screw IS-M5x6 (2) USA, CDN
54	0000 967 3699	1	Instruction label (2) USA
55	0000 967 3902	1	Instruction label (2) CDN
56	9022 341 1220	1	Spline screw IS-M5x48
57	4224 967 3702	1	Instruction label (1) J

(1) TS 800, (2) TS 800-Z

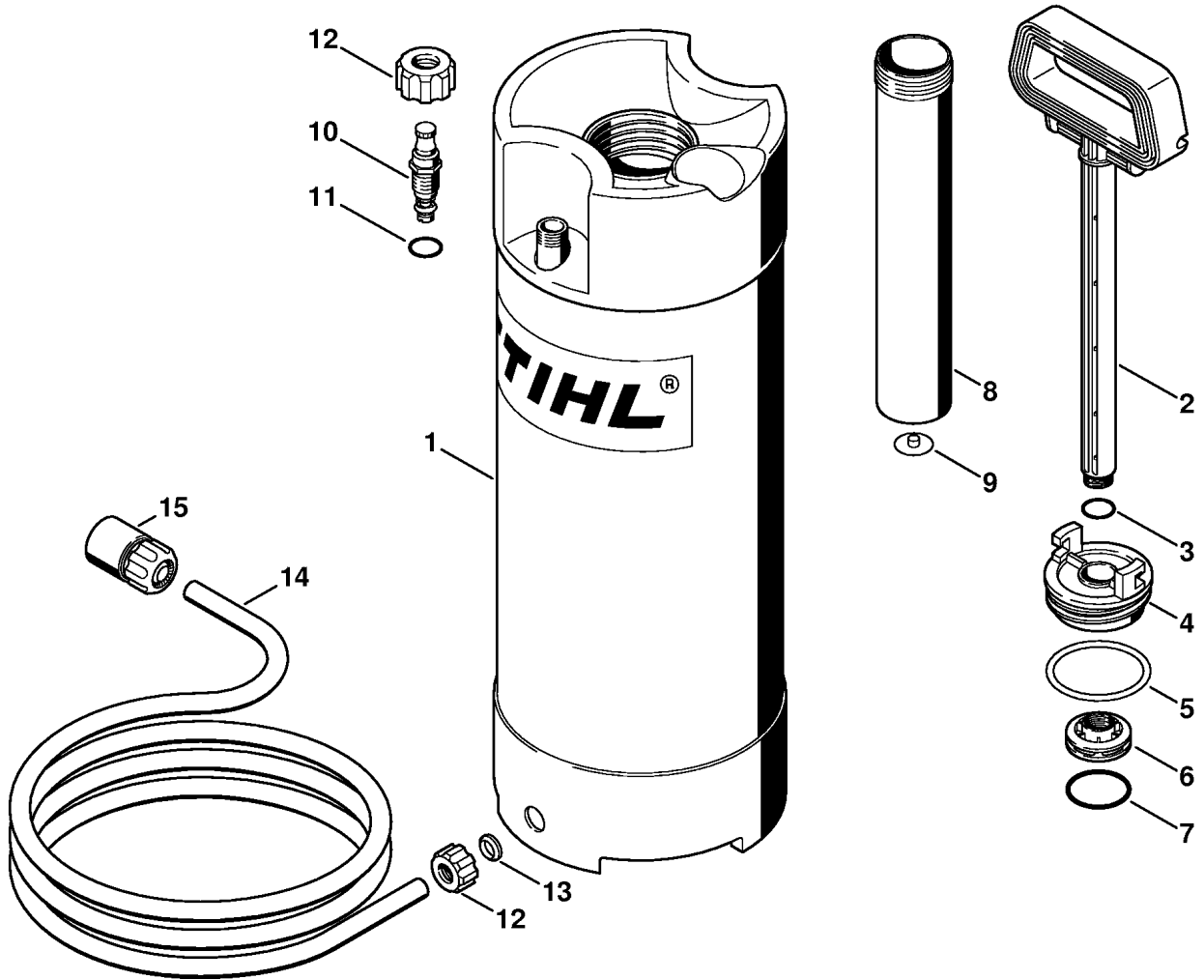

337ET021 GM

Reference	Item number	Qty	Description
	4223 670 6000	1	Water tank (B) □ 1 - 14
	4223 670 6001	1	Water tank (B) USA □ 1 - 15
1	4223 670 6010	1	Water tank (B) □ 12, 13
2	4223 670 7700	1	Handle (B) □ 3
3	9645 945 7560	1	O-ring 14x1.78 (B)
4	4223 670 8600	1	Filler cap (B) □ 5
5	9645 945 8240	1	O-ring 56.5x 5.33 (B)
6	4223 670 8200	1	Piston (B) □ 7
7	9645 945 7958	1	O-ring 37.5x3.15 (B)
8	4223 670 6600	1	Pump barrel (B) □ 9
9	4223 678 2600	1	Valve (B)
10	4223 670 5000	1	Valve (B) □ 11
11	9645 945 7494	1	O-ring 8.76x1.78 (B)
12	4223 677 8300	2	Union nut (B)
13	4223 678 1600	1	Insert (B)
14	4309 678 1100	1	Hose 4 m / 158" (B)
15	4201 670 1700	1	Coupling sleeve 1/2" (B)

(1) TS 800, (2) TS 800-Z

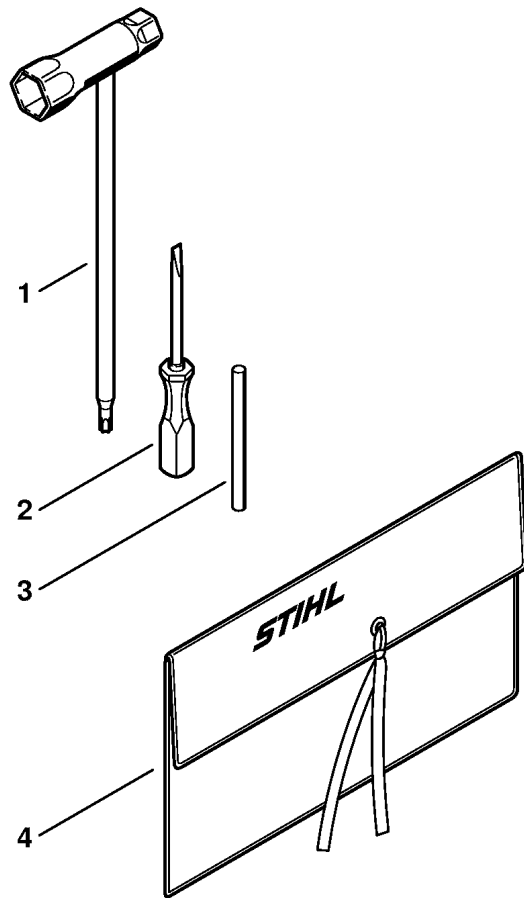

376ET009 SC

Reference	Item number	Qty	Description
1	4224 890 3400	1	Combination wrench
2	5910 890 2305	1	Screwdriver
3	4130 893 7800	1	Locking pin
4	0000 891 0801	1	Tool roll

(1) TS 800, (2) TS 800-Z

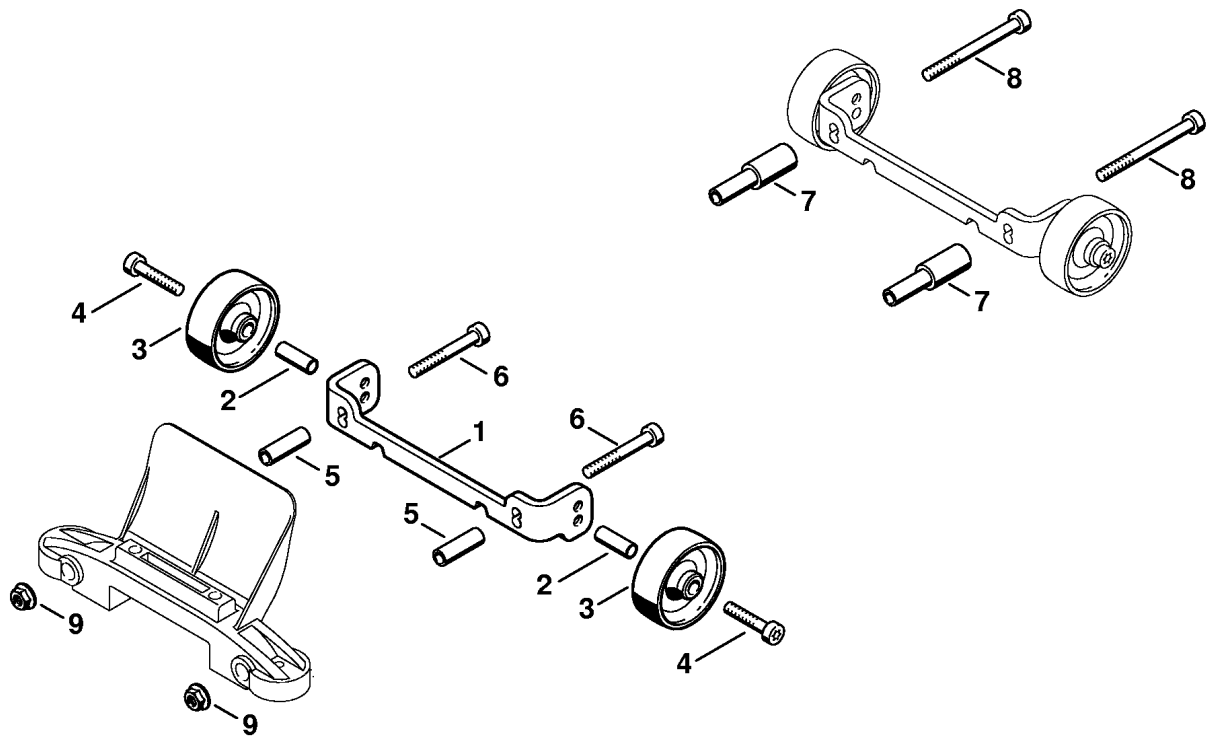

376ET022 SC

Reference	Item number	Qty	Description
	4224 007 1014	1	Mounting kit wheels (B)
		□ 1 - 9	
1		1	Carrier (B,D)
2	4223 791 7200	2	Sleeve (B)
3	4223 791 3600	2	Wheel (B)
4	9007 319 1370	2	Hexagon head screw M6x30 (B)
5	4224 791 7204	2	Sleeve (B)
6	9007 319 1420	2	Hexagon head screw M6x45 (B)
7	4224 791 7205	2	Sleeve (B)
8	9007 319 1460	2	Hexagon head screw M6x65 (B)
9	9220 260 0900	2	Hexagon nut M6 (B)

(1) TS 800, (2) TS 800-Z