

2710ET000 SC

Reference	Item number	Qty	Description
1	1141 020 3001	1	Engine housing (1,2,4,5) □ 4, 5, 7 - 10, 12, 14, 16 - 18
2	1141 020 3003	1	Engine housing (3,6,7) □ 4, 5, 7 - 10, 15 - 18
3	1141 020 3005	1	Engine housing (8,9) □ 4 - 9, 11, 15 - 18
4	1128 640 9100	1	Valve
5	0000 974 1200	1	Notched pin 2.6x8
6	0000 974 1200	1	Notched pin 2.6x8 (8,9)
7	1141 162 5205	1	Pin
8	1121 162 5200	1	Pin
9	1120 162 5200	1	Pin
10	1123 162 5200	1	Pin (1-7)
11	1141 162 5205	1	Pin (8,9)
12	0000 664 2404	1	Collar screw M8 (1,2,4,5)
13	0000 664 2411	1	Collar screw D9/M8 (B) (1,2,4,5)
14	0000 664 2407	1	Collar screw M8 (1,2,4,5)
15	0000 664 2403	1	Collar screw D8 (3,6,7-9)
16	1117 640 3800	1	Pickup body
17	1141 647 9401	1	Hose
18	1141 791 5902	1	Stop buffer
19	0000 350 0504	1	Filler cap □ 20
20	9645 948 7734	1	O-ring 25x3.5
21	1141 141 7500	1	Pre-separator
22	9074 477 4130	1	Pan head self-tapping screw IS-P5x16
23	1141 656 7700	1	Chain catcher
24	9074 477 4438	1	Pan head self-tapping screw IS-P6x30

(1) MS 271, (2) MS 271-Z, (3) MS 271 C-BE, (4) MS 291, (5) MS 291-Z, (6) MS 291 C-BE, (7) MS 291 C-BE Z,
(8) MS 291 C-BEQ, (9) MS 291 C-BEQ Z

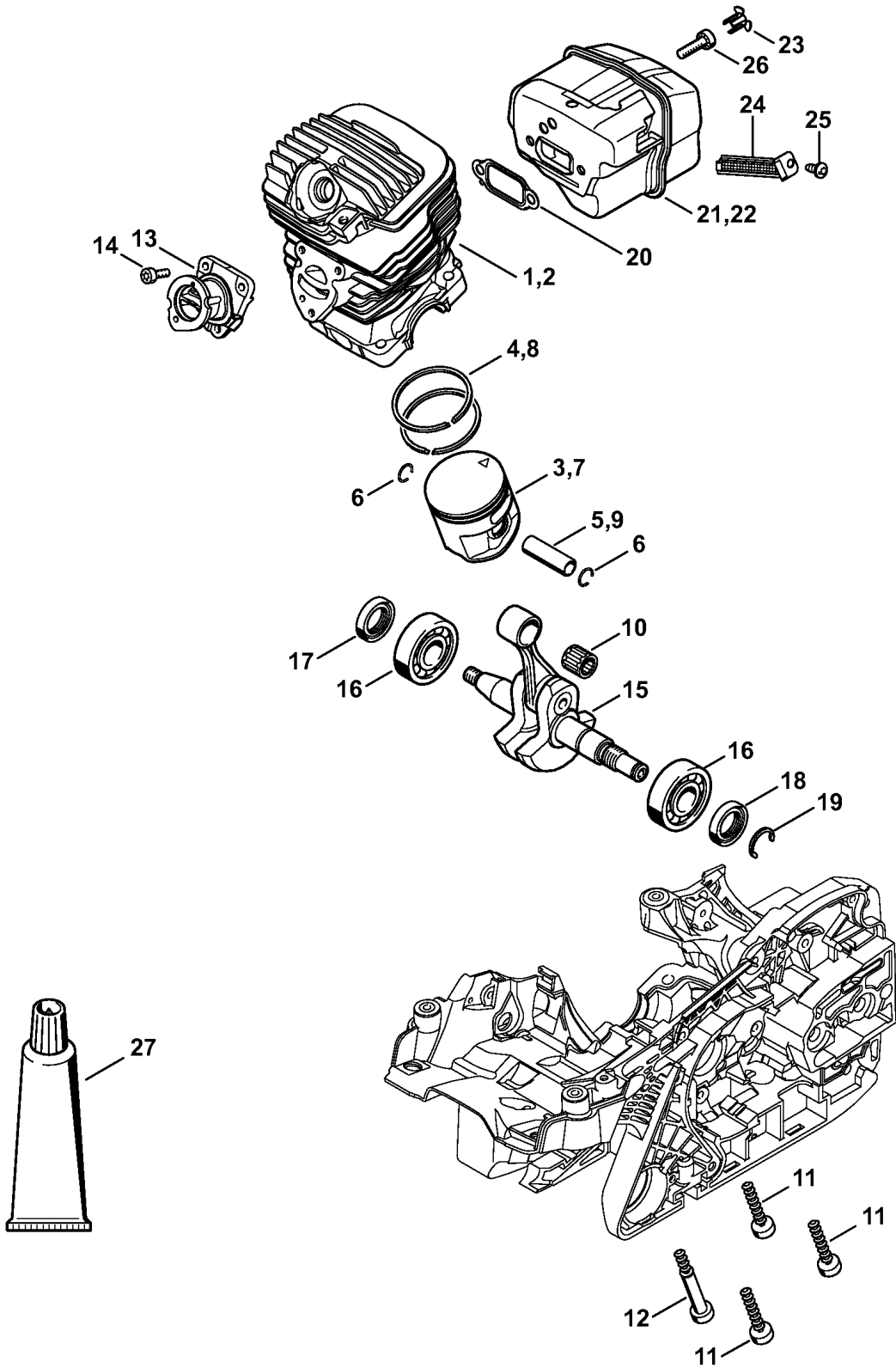

2710ET001 SC

Reference	Item number	Qty	Description
1	1141 020 1203	1	Cylinder with piston Ø 44.7 mm (1-3) □ 3 - 6
2	1141 020 1201	1	Cylinder with piston Ø 47 mm (4-9) □ 6 - 9
3	1141 030 2012	1	Piston Ø 44.7 mm (1-3) □ 4 - 6
4	1141 034 3000	2	Piston ring Ø 44.7x1.2 mm (1-3)
5	1141 034 1502	1	Piston pin 10x6x32 (1-3)
6	9463 650 1000	2	Snap ring 10
7	1141 030 2011	1	Piston Ø 47 mm (4-9) □ 6 - 9
8	1140 034 3000	2	Piston ring Ø 47x1.2 mm (4-9)
9	1141 034 1503	1	Piston pin 10x6x35 (4-9)
10	9512 003 2330	1	Needle cage 10x14x13.5
11	9075 478 4725	3	Pan head self-tapping screw IS-D6x35
12	1141 028 0201	1	Pan head self-tapping screw IS-D6x50
13	1141 140 2500	1	Manifold
14	9022 313 0660	3	Spline screw IS-M4x12
15	1141 030 0401	1	Crankshaft (25.2005)
16	9523 003 4301	2	Grooved ball bearing 15x38x11
17	9638 003 1581	1	Oil seal 15x25x5
18	9639 951 1584	1	Oil seal 15x25x5
19	9468 621 1520	1	Circlip 15x1
20	1141 149 0600	1	Muffler gasket
21	1141 140 0611	1	Muffler (1,3,4,6,8) □ 23
22	1141 140 0613	1	Muffler (2,5,7,9) USA □ 23 - 25
23	1135 145 9002	2	Plug
24	1141 140 8100	1	Spark arresting screen (2,5,7,9) USA
25	9039 475 0656	1	Self-tapping screw M4x9.6 (2,5,7,9) USA
26	9075 478 4085	2	Pan head self-tapping screw IS-D5x18
27	0783 830 2000	1	Tube of sealant Dirko HT red (B)

(1) MS 271, (2) MS 271-Z, (3) MS 271 C-BE, (4) MS 291, (5) MS 291-Z, (6) MS 291 C-BE, (7) MS 291 C-BE Z, (8) MS 291 C-BEQ, (9) MS 291 C-BEQ Z

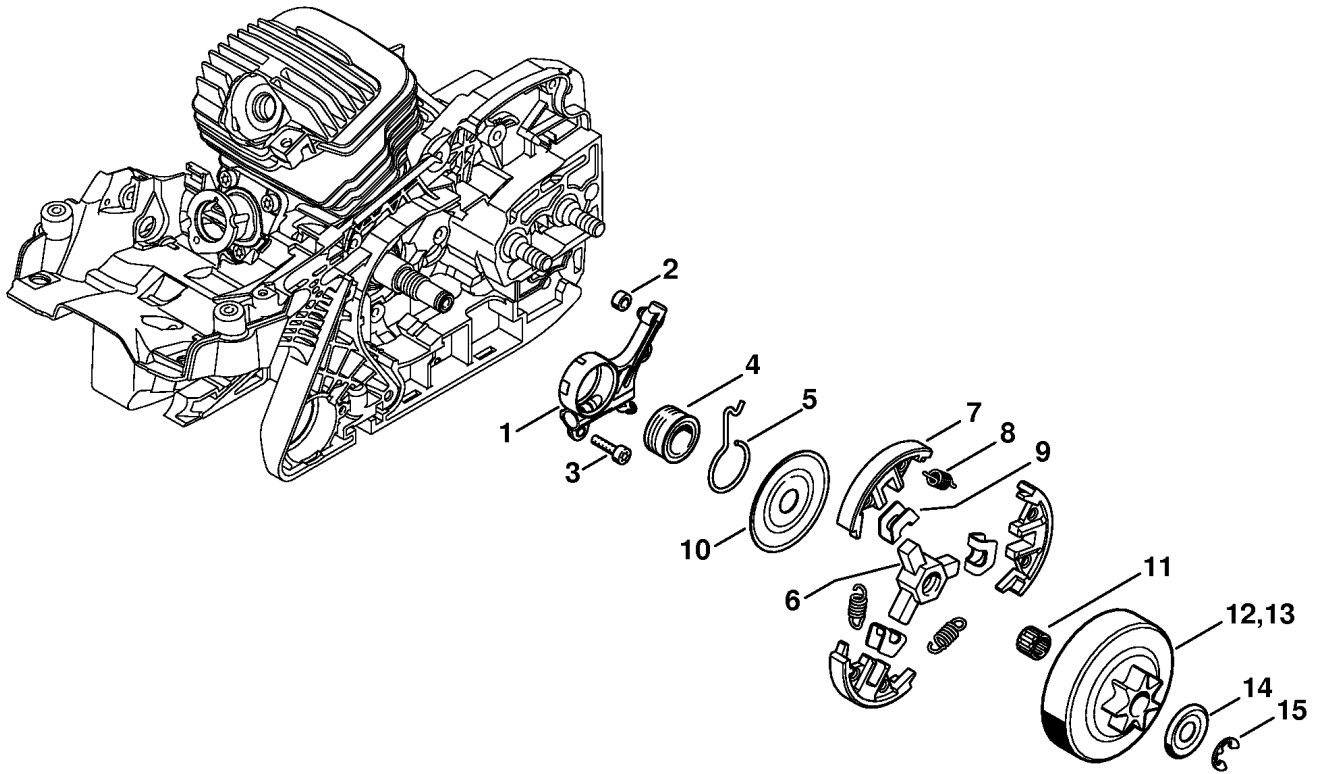

2710ET002 SC

Reference	Item number	Qty	Description
1	1141 640 3203	1	Oil pump
2	1122 649 5000	1	Sealing ring B4x2
3	9075 478 3018	2	Pan head self-tapping screw IS-D4x18
4	1133 640 7100	1	Worm □ 5
5	1133 647 2400	1	Spring
	1121 160 2051	1	Clutch □ 6 - 10
6	1121 162 3201	1	Carrier
7	1121 162 0802	3	Clutch shoe
8	0000 997 5600	3	Tension spring
9	1127 162 3000	3	Retainer
10	1121 162 1001	1	Cover washer
11	9512 933 2260	1	Needle cage 10x13x10
12	1141 640 2001	1	Chain sprocket 0.325" 7T (1-7)
13	1141 640 2003	1	Chain sprocket 3/8" 7T (4,6)
14	0000 958 1022	1	Washer Ø 27 mm
15	9460 624 0801	1	E-clip 8x1.3

(1) MS 271, (2) MS 271-Z, (3) MS 271 C-BE, (4) MS 291, (5) MS 291-Z, (6) MS 291 C-BE, (7) MS 291 C-BE Z, (8) MS 291 C-BEQ, (9) MS 291 C-BEQ Z

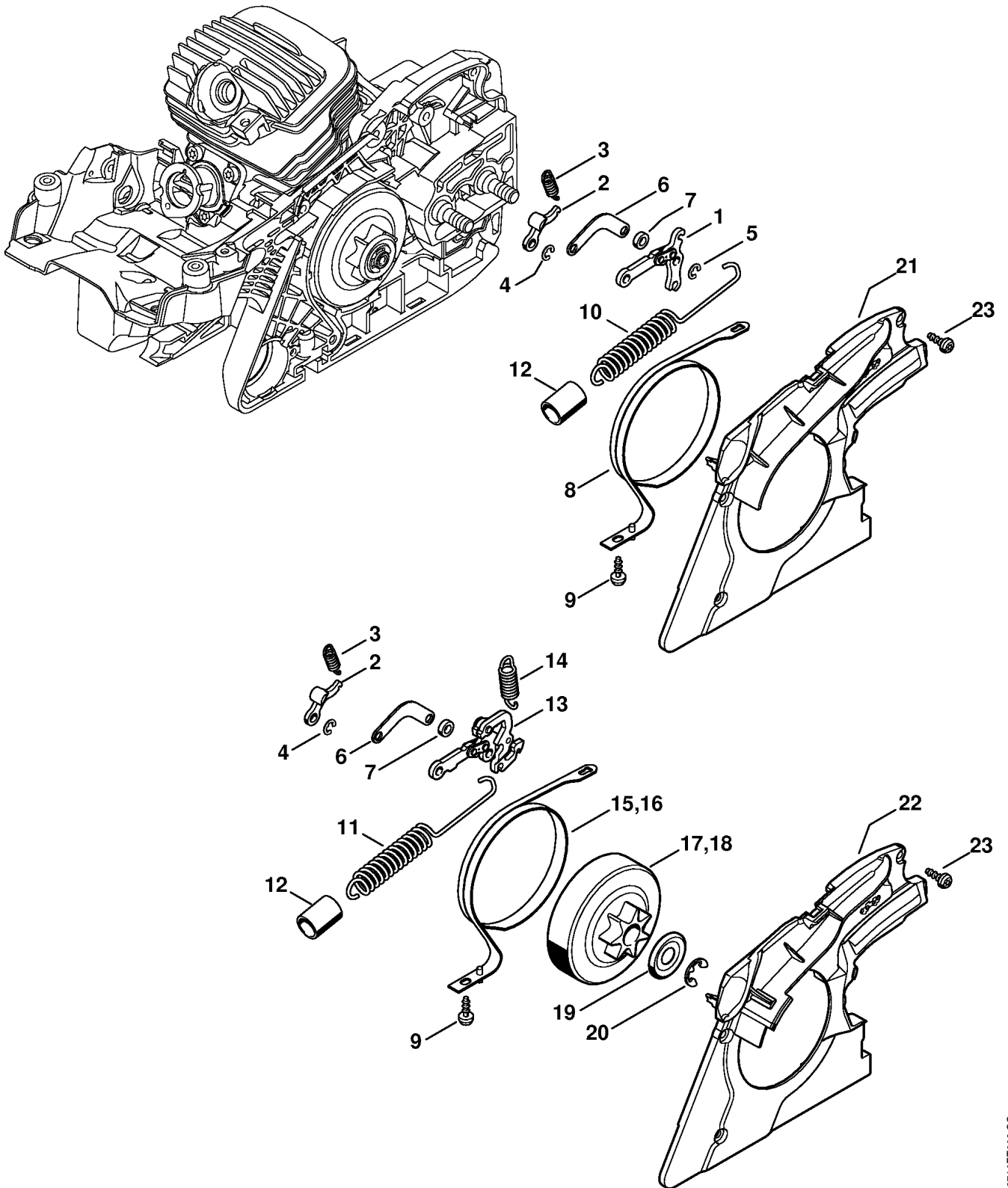

2710ET003 SC

Reference	Item number	Qty	Description
1	1128 160 5000	1	Lever (1-7)
2	1121 162 5010	1	Lever
3	0000 997 0628	1	Spring
4	9460 624 0400	1	E-clip 4
5	9460 624 0400	1	E-clip 4 (1-7)
6	1141 162 5801	1	Strap
7	1141 162 9401	1	Spacer
8	1141 160 5400	1	Brake band (1-7)
9	9074 477 2995	1	Pan head self-tapping screw IS-P4x12
10	1141 160 5500	1	Tension spring (1-7) □ 12
11	1141 160 5502	1	Tension spring (8,9) □ 12
12	1125 162 8002	1	Hose 20 mm / 13/16"
13	1133 160 5000	1	Brake lever (8,9)
14	1125 162 7905	1	Tension spring (8,9)
15	1141 160 5411	1	Brake band 3/8" 7T (8) □ 17
16	1141 160 5416	1	Brake band 0.325" 7T (8,9) □ 18
17		1	Chain sprocket 3/8" 7T (D) (8)
18		1	Chain sprocket 0.325" 7T (D) (8,9)
19	0000 958 1022	1	Washer Ø 27 mm (8,9)
20	9460 624 0801	1	E-clip 8x1.3 (8,9)
21	1141 021 1101	1	Cover (1,2,4,5)
22	1141 021 1103	1	Cover (3,6-9)
23	9074 477 2995	3	Pan head self-tapping screw IS-P4x12

(1) MS 271, (2) MS 271-Z, (3) MS 271 C-BE, (4) MS 291, (5) MS 291-Z, (6) MS 291 C-BE, (7) MS 291 C-BE Z, (8) MS 291 C-BEQ, (9) MS 291 C-BEQ Z

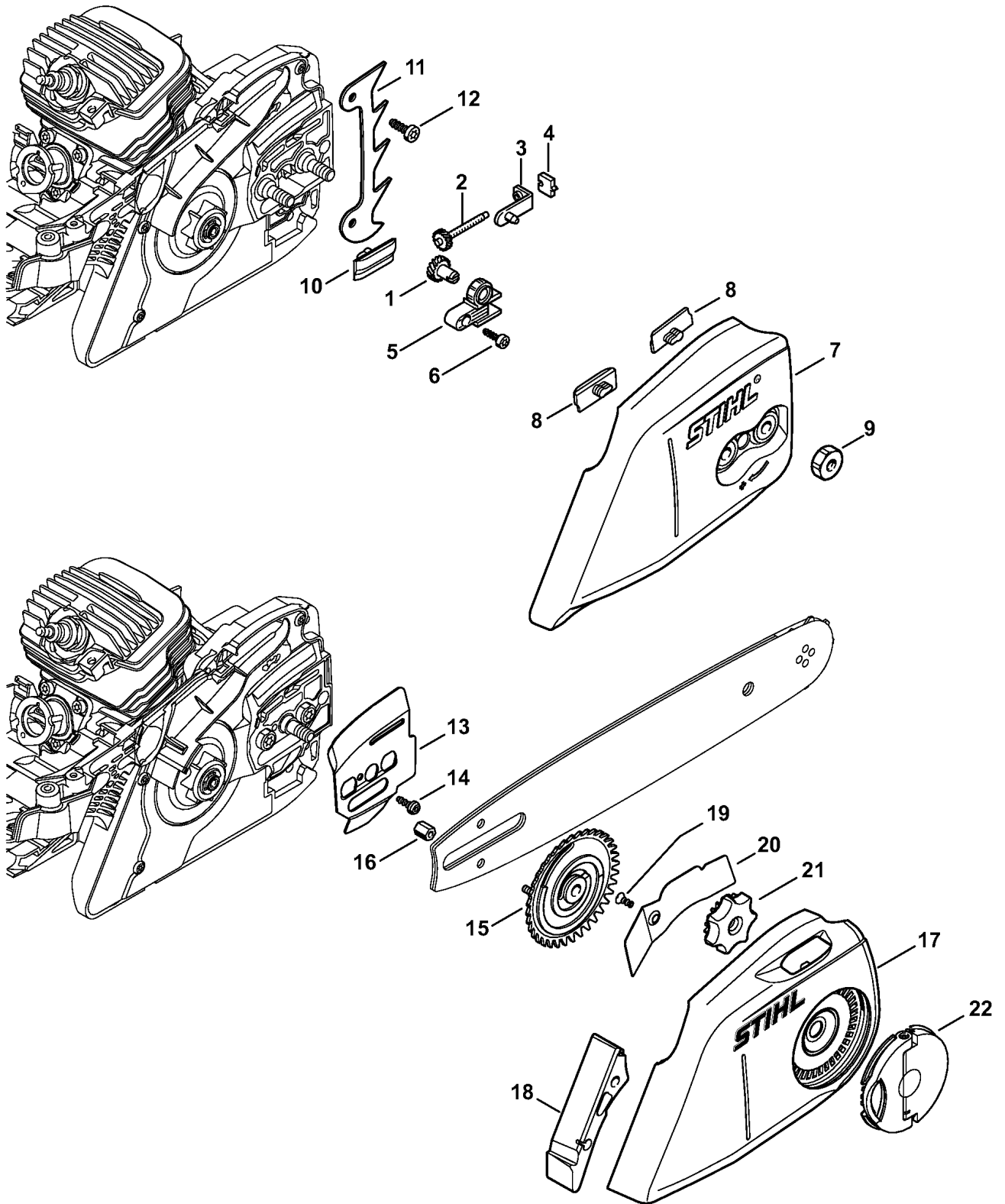

2710ET004 SC

Reference	Item number	Qty	Description
	1127 007 1003	1	Spur gear / chain adjusting screw kit (1,2,4,5) □ 1, 2
1		1	Spur gear (D) (1,2,4,5)
2		1	Adjusting screw (D) (1,2,4,5)
3	1127 640 1900	1	Tensioner slide (1,2,4,5)
4	1123 664 1400	1	Thrust pad (1,2,4,5)
5	1127 664 2200	1	Cover (1,2,4,5)
6	9074 477 2995	1	Pan head self-tapping screw IS-P4x12 (1,2,4,5)
7	1140 640 1700	1	Chain sprocket cover (1,2,4,5) □ 8
8	1121 648 6610	2	Bumper strip (1,2,4,5)
9	0000 955 0801	2	Hexagon nut M8 (1,2,4,5)
10	1121 648 6610	1	Bumper strip (1,2,4,5)
11	1110 664 0501	1	Bumper spike
12	9074 477 4130	2	Pan head self-tapping screw IS-P5x16
13	1141 664 1002	1	Inner side plate (3,6-9)
14	9074 477 2995	1	Pan head self-tapping screw IS-P4x12 (3,6-9)
15	1135 660 3000	1	Tensioning gear (3,6-9) □ 16
16	1121 664 7301	1	Nut M4 (3,6-9)
17	1135 640 1702	1	Chain sprocket cover (3,6-9) □ 18 - 21
18	1135 656 1500	1	Guard (3,6-9)
19	9076 478 2996	1	Pan head self-tapping screw P4x12 (3,6-9)
20	1135 648 3800	1	Cover plate (3,6-9)
21	1121 648 2200	1	Adjusting wheel (3,6-9)
22	1121 660 1000	1	Wing nut (3,6-9)

(1) MS 271, (2) MS 271-Z, (3) MS 271 C-BE, (4) MS 291, (5) MS 291-Z, (6) MS 291 C-BE, (7) MS 291 C-BE Z, (8) MS 291 C-BEQ, (9) MS 291 C-BEQ Z

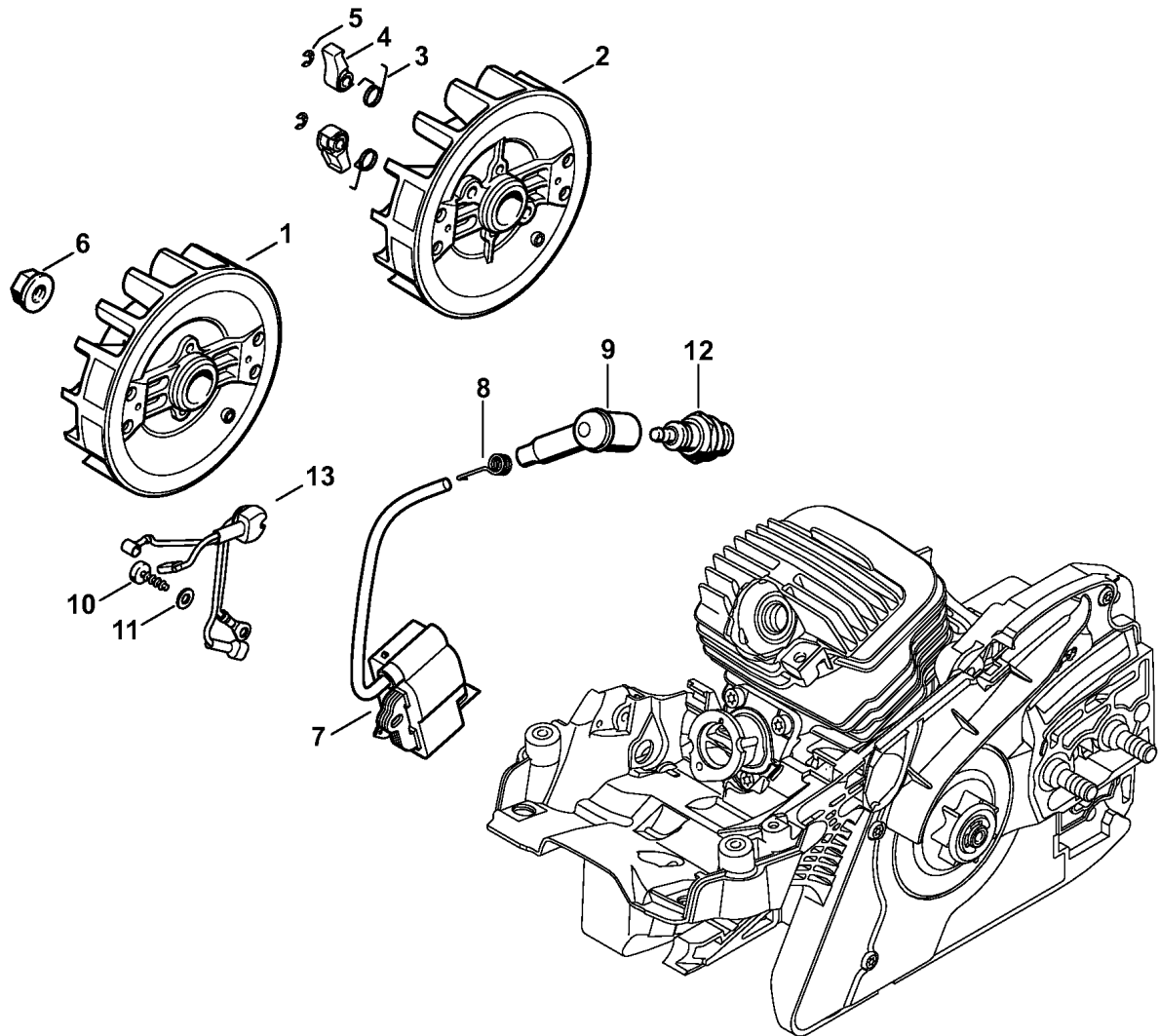

2710ET005 SC

Reference	Item number	Qty	Description
1	1141 400 1200	1	Flywheel (1,2,4,5) (25.2005)
2	1141 400 1202	1	Flywheel (3,6-9) (25.2005) □ 3 - 5
3	0000 998 1100	2	Torsion spring (3,6-9)
4	1139 195 7200	2	Pawl (3,6-9)
5	9460 624 0320	2	E-clip 3.2 (3,6-9)
6	0000 955 0802	1	Collar nut M8x1
7	1141 400 1303	1	Ignition module □ 8, 9
8	0000 998 0603	1	Torsion spring
9	1106 405 1000	1	Spark plug boot
10	9075 478 3018	2	Pan head self-tapping screw IS-D4x18
11	9291 021 0100	2	Washer 4.3
12	0000 400 7000	1	Spark plug NGK BPMR7A
13	1141 440 3000	1	Wiring harness

(1) MS 271, (2) MS 271-Z, (3) MS 271 C-BE, (4) MS 291, (5) MS 291-Z, (6) MS 291 C-BE, (7) MS 291 C-BE Z, (8) MS 291 C-BEQ, (9) MS 291 C-BEQ Z

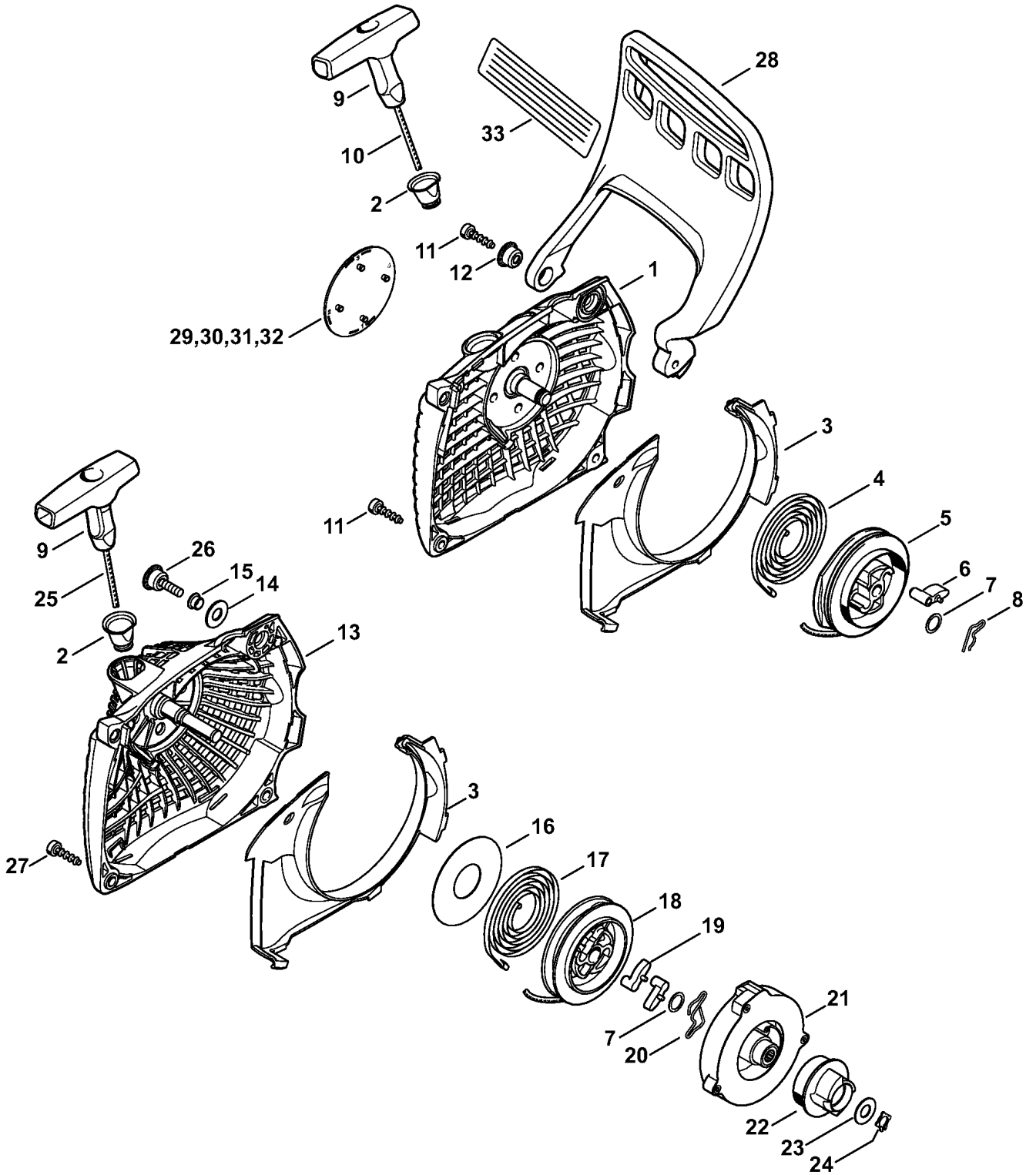

2710ET006 SC

Reference	Item number	Qty	Description
	1141 080 2101	1	Fan housing with rewind starter (1,2,4,5) □ 2 - 10
1	1141 080 1801	1	Fan housing (1,2,4,5) □ 2
2	1110 084 9102	1	Bushing
3	1141 084 7802	1	Segment
4	1135 190 0600	1	Rewind spring (1,2,4,5)
5	1128 195 0400	1	Rope rotor (1,2,4,5)
6	1125 195 7200	1	Pawl (1,2,4,5)
7	0000 958 0923	1	Washer
8	1118 195 3500	1	Spring
9	1121 195 3400	1	Starter grip
10	1113 195 8200	1	Starter rope Ø 3.5x960 mm (1,2,4,5)
	0000 930 2267	1	Starter rope Ø 3.5 mm / 28 pieces (A,B) (1,2,4,5)
11	9074 477 4135	4	Pan head self-tapping screw IS-P5x20 (1,2,4,5)
12	1133 791 7201	1	Sleeve (1,2,4,5)
	1141 080 2102	1	Fan housing with rewind starter (3,6-9) □ 2, 3, 7, 9, 13 - 25
13	1141 080 1804	1	Fan housing (3,6-9) □ 2, 14, 15
14	4117 162 8900	1	Washer (3,6-9)
15	1141 988 8600	1	Sleeve (3,6-9)
16	1141 195 9004	1	Washer (3,6-9)
17	1123 190 0600	1	Rewind spring (3,6-9)
18	1141 195 0400	1	Rope rotor (3,6-9)
19	1123 195 7200	2	Pawl (3,6-9)
20	1128 195 3500	1	Spring (3,6-9)
21	1141 190 0700	1	Spring housing (3,6-9)
22	1141 195 2000	1	Carrier (3,6-9)
23	0000 958 0810	1	Washer (3,6-9)
24	9455 621 0575	1	Circlip 8x1 (3,6-9)
25	1141 195 8200	1	Starter rope Ø 3x960 mm (3,6-9)
26	1141 790 6101	1	Screw assy. (3,6-9)
27	9074 477 4135	3	Pan head self-tapping screw IS-P5x20 (3,6-9)
28	1141 792 9101	1	Hand guard
29	1141 967 1501	1	Model plate MS 271 (1,2)
30	1141 967 1505	1	Model plate MS 271 C (3)
31	1141 967 1503	1	Model plate MS 291 (4,5)
32	1141 967 1507	1	Model plate MS 291C (6-9)

(1) MS 271, (2) MS 271-Z, (3) MS 271 C-BE, (4) MS 291, (5) MS 291-Z, (6) MS 291 C-BE, (7) MS 291 C-BE Z, (8) MS 291 C-BEQ, (9) MS 291 C-BEQ Z

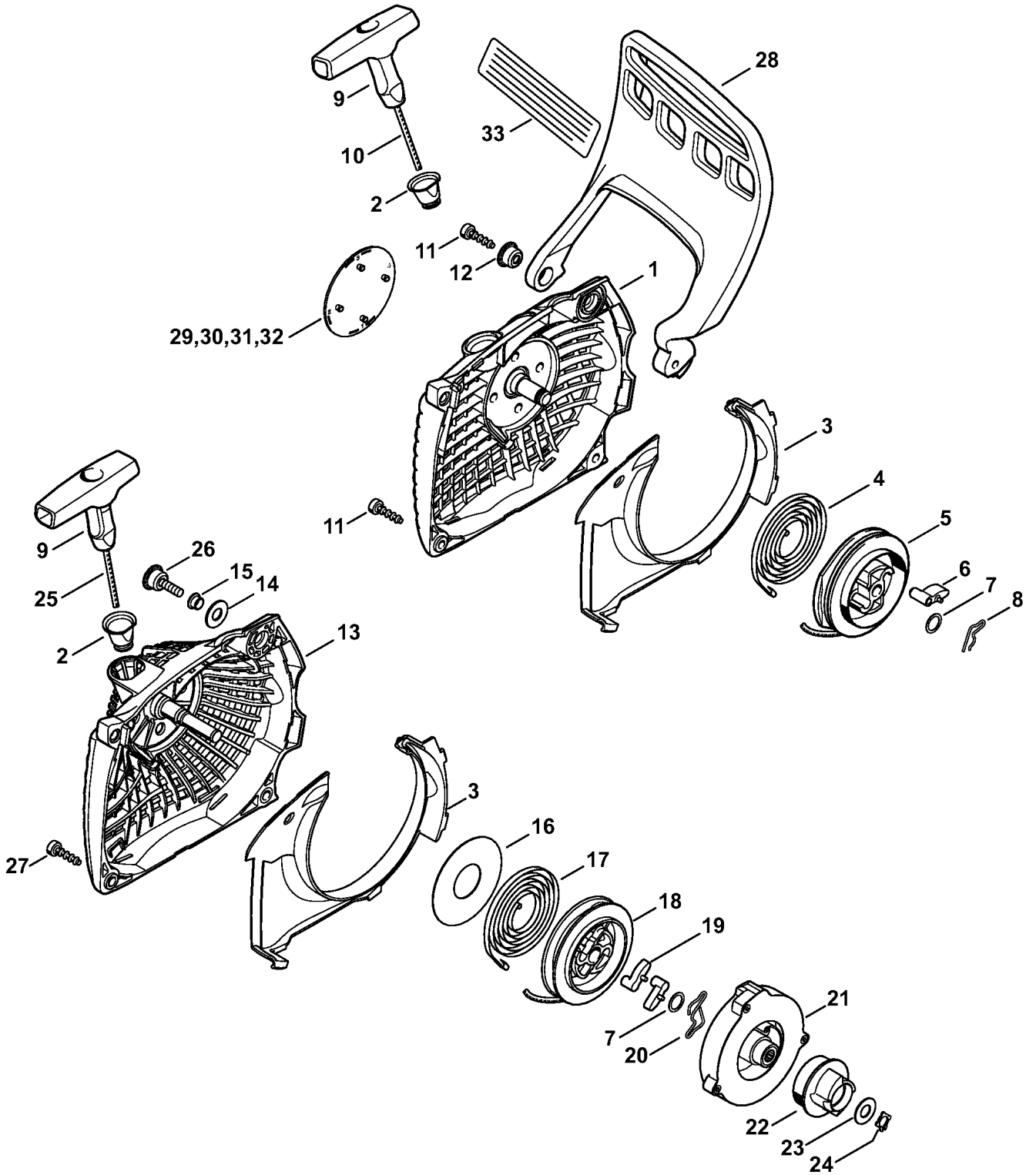

2710ET006 SC

Reference	Item number	Qty	Description
33	0000 967 3630	1	Instruction label USA

(1) MS 271, (2) MS 271-Z, (3) MS 271 C-BE, (4) MS 291, (5) MS 291-Z, (6) MS 291 C-BE, (7) MS 291 C-BE Z, (8) MS 291 C-BEQ, (9) MS 291 C-BEQ Z

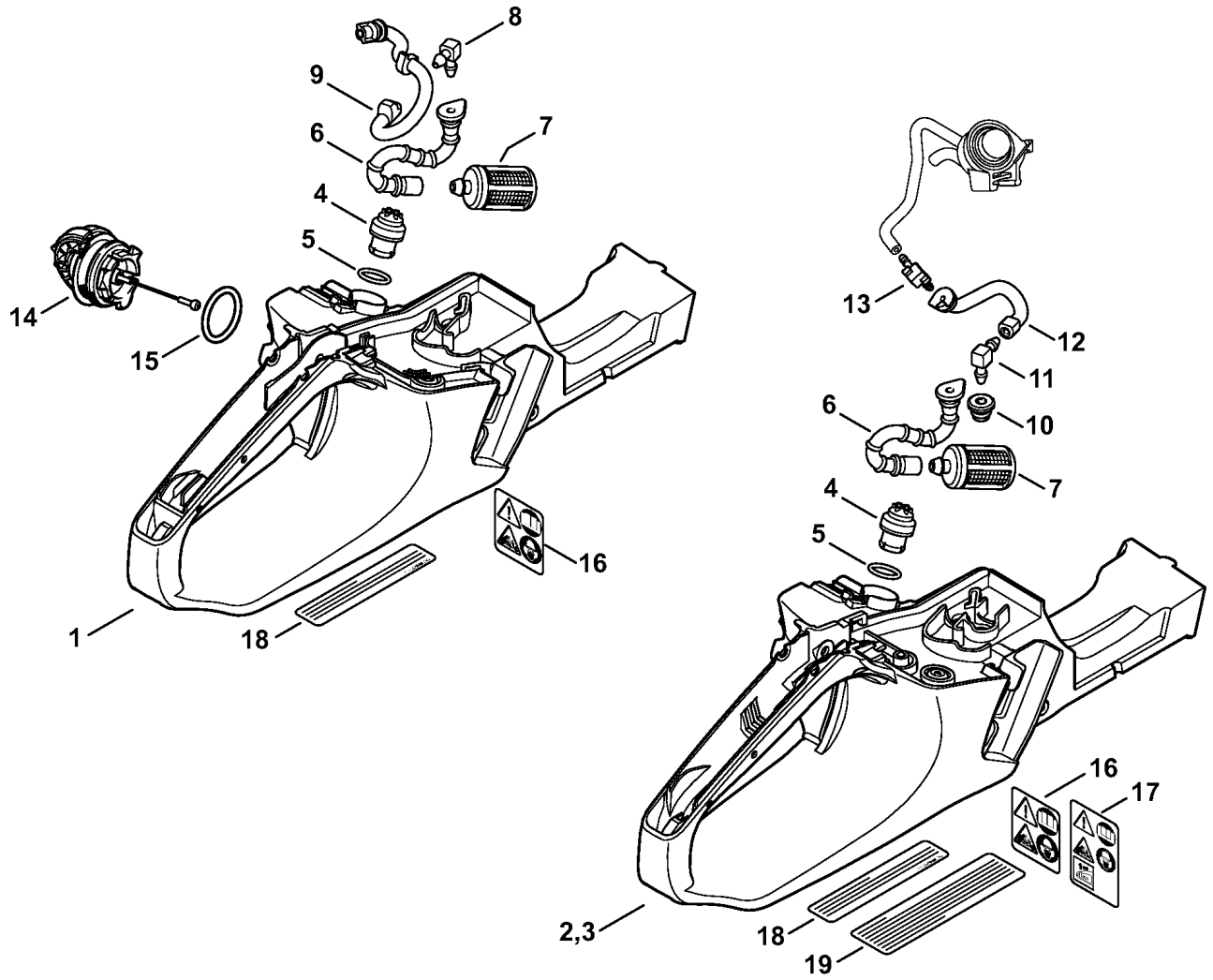

2710ET007 SC

Reference	Item number	Qty	Description
1	1141 350 0820	1	Tank housing (1,2,4,5) □ 4 - 7, 14 - 16
2	1141 350 0822	1	Tank housing (3,6,7) □ 4 - 7, 10, 14 - 16
3	1141 350 0821	1	Tank housing (8,9) □ 4 - 7, 10, 14, 15, 17
4	0000 350 5800	1	Tank vent □ 5
5		1	O-ring (D)
6	1141 358 7708	1	Hose
7	0000 350 3504	1	Pickup body
8	4224 122 3900	1	Elbow connector
9	1141 358 7700	1	Hose
10	1141 989 0600	1	Grommet (3,6-9)
11	4224 122 3900	1	Elbow connector (3,6-9)
12	1141 358 7702	1	Hose (3,6-9)
13	1143 353 2601	1	Elbow connector (3,6-9)
14	0000 350 0504	1	Filler cap □ 15
15	9645 948 7734	1	O-ring 25x3.5
16	0000 967 3632	1	Warning pictogram MS (1-7)
17	0000 967 4011	1	Warning pictogram QS (8,9)
18	0000 967 3500	1	Instruction label (2,5,9)
19	0000 967 4012	1	Instruction label (9)

(1) MS 271, (2) MS 271-Z, (3) MS 271 C-BE, (4) MS 291, (5) MS 291-Z, (6) MS 291 C-BE, (7) MS 291 C-BE Z, (8) MS 291 C-BEQ, (9) MS 291 C-BEQ Z

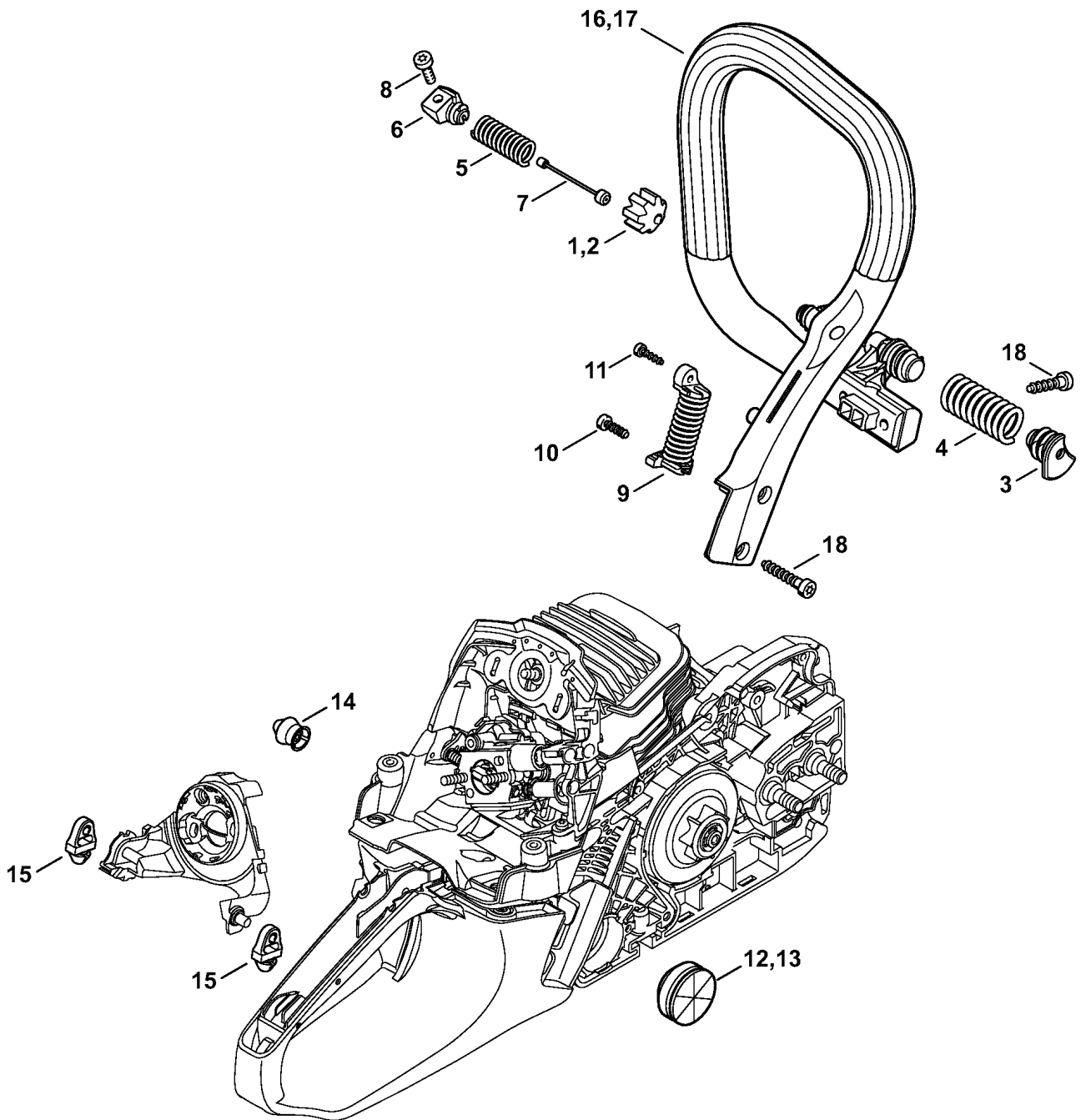

2710ET008 SC

Reference	Item number	Qty	Description
1	1141 791 2802	1	Annular buffer (1,3,4,6,8)
2	1135 791 2800	1	Annular buffer (2,5,7,9)
3	1141 792 2900	1	Bearing plug
4	1141 791 3112	1	Spring
5	1141 791 3102	1	Spring
6	1141 792 2902	1	Bearing plug
7	1135 790 8100	1	Retainer
8	9075 478 4085	1	Pan head self-tapping screw IS-D5x18
9	1141 790 8304	1	AV-Spring
10	9074 477 4130	1	Pan head self-tapping screw IS-P5x16
11	9104 003 3004	1	Self-tapping screw P4x14
12	1138 791 5903	1	Stop buffer (1,3,4,6,8)
13	1140 791 5901	1	Stop buffer (2,5,7,9)
14	1141 791 5902	1	Stop buffer
15	1141 122 9902	2	Buffer
16	1141 791 1700	1	Handlebar (1,2,4,5)
17	1141 791 1702	1	Handlebar (3,6-9)
18	9074 478 4675	4	Pan head self-tapping screw IS-P6x32.5

(1) MS 271, (2) MS 271-Z, (3) MS 271 C-BE, (4) MS 291, (5) MS 291-Z, (6) MS 291 C-BE, (7) MS 291 C-BE Z, (8) MS 291 C-BEQ, (9) MS 291 C-BEQ Z

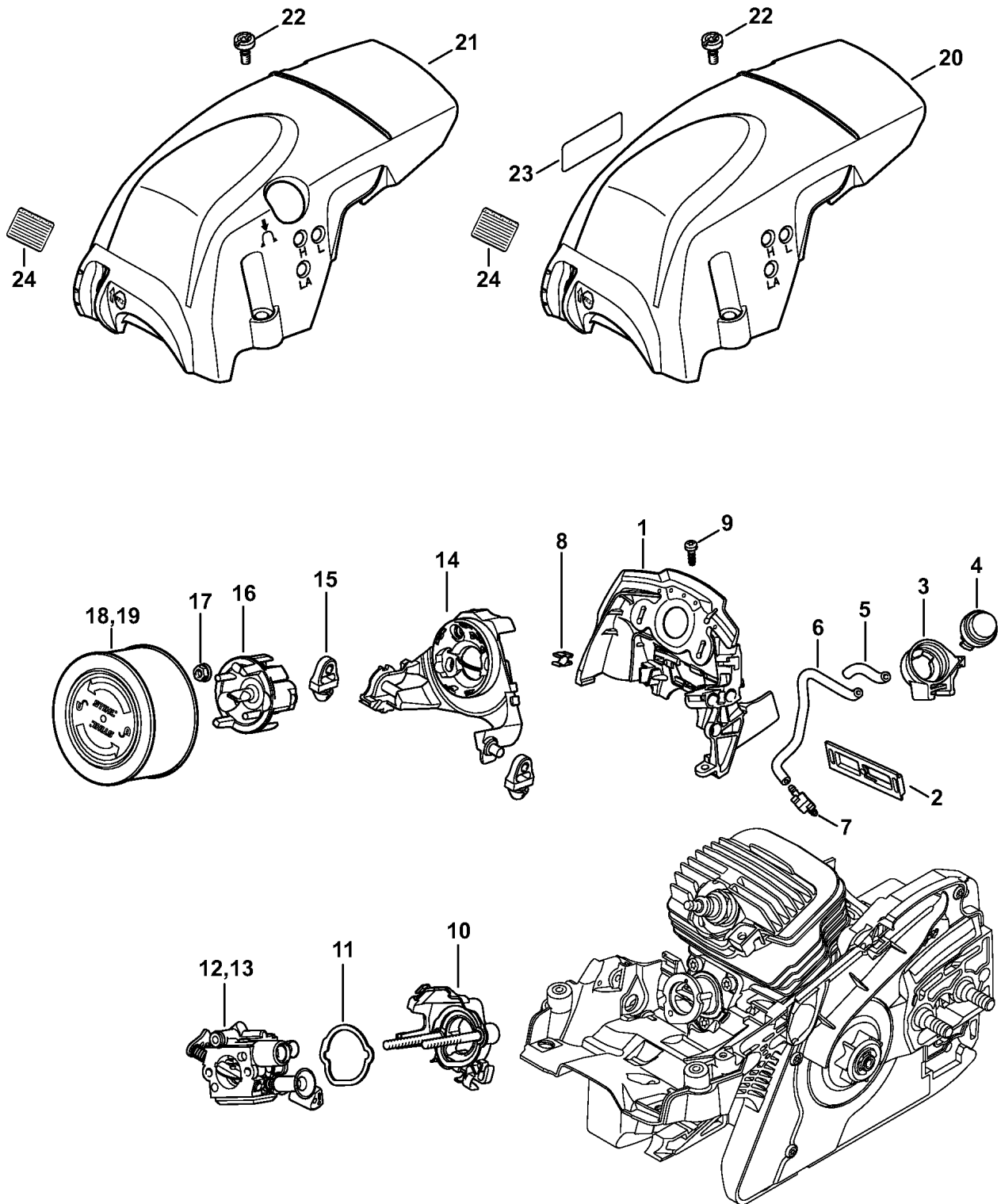

2710ET012 AM

Reference	Item number	Qty	Description
1	1141 087 3000	1	Air guide shroud
2	1141 084 4100	1	Shutter
3	1141 352 8200	1	Clamp (3,6-9)
4	0000 350 6201	1	Fuel pump (3,6-9)
5		1	Hose 2.2x5.4x53 mm (D) (3,6-9)
6		1	Hose 2.2x5.4x155 mm (D) (3,6-9)
	0000 937 5006	1	Hose 2.2x5.4 mm x 1 m (A,B) (3,6-9)
7	1143 353 2601	1	Elbow connector (3,6-9)
8	1141 122 2500	1	Hose clip (3,6-9)
9	9074 477 2995	1	Pan head self-tapping screw IS-P4x12
10	1141 120 0900	1	Carburetor bracket
11	1141 121 8600	1	Washer
12	1141 120 0601	1	Carburetor C1Q-S181A (1,2,4,5)
13	1141 120 0603	1	Carburetor C1Q-S182A (3,6-9)
14	1141 141 0900	1	Filter base
15	1141 122 9902	2	Buffer
16	1141 121 6900	1	Baffle
17	9216 261 0700	2	Hexagon nut M5
18	1141 120 1600	1	Air filter, fleece
19	1141 120 1604	1	Air filter HD2 (B)
20	1141 080 1601	1	Shroud (1,2,4,5) □ 22
21	1141 080 1603	1	Shroud (3,6-9) □ 22
22	9022 319 1028	3	Screw IS-M5x14
23	0000 967 3749	1	Warning pictogram Filler cap (2,5,7,9) USA
24	0000 967 4055	1	Warning Spark arresting screen (2,5,7,9) USA

(1) MS 271, (2) MS 271-Z, (3) MS 271 C-BE, (4) MS 291, (5) MS 291-Z, (6) MS 291 C-BE, (7) MS 291 C-BE Z, (8) MS 291 C-BEQ, (9) MS 291 C-BEQ Z

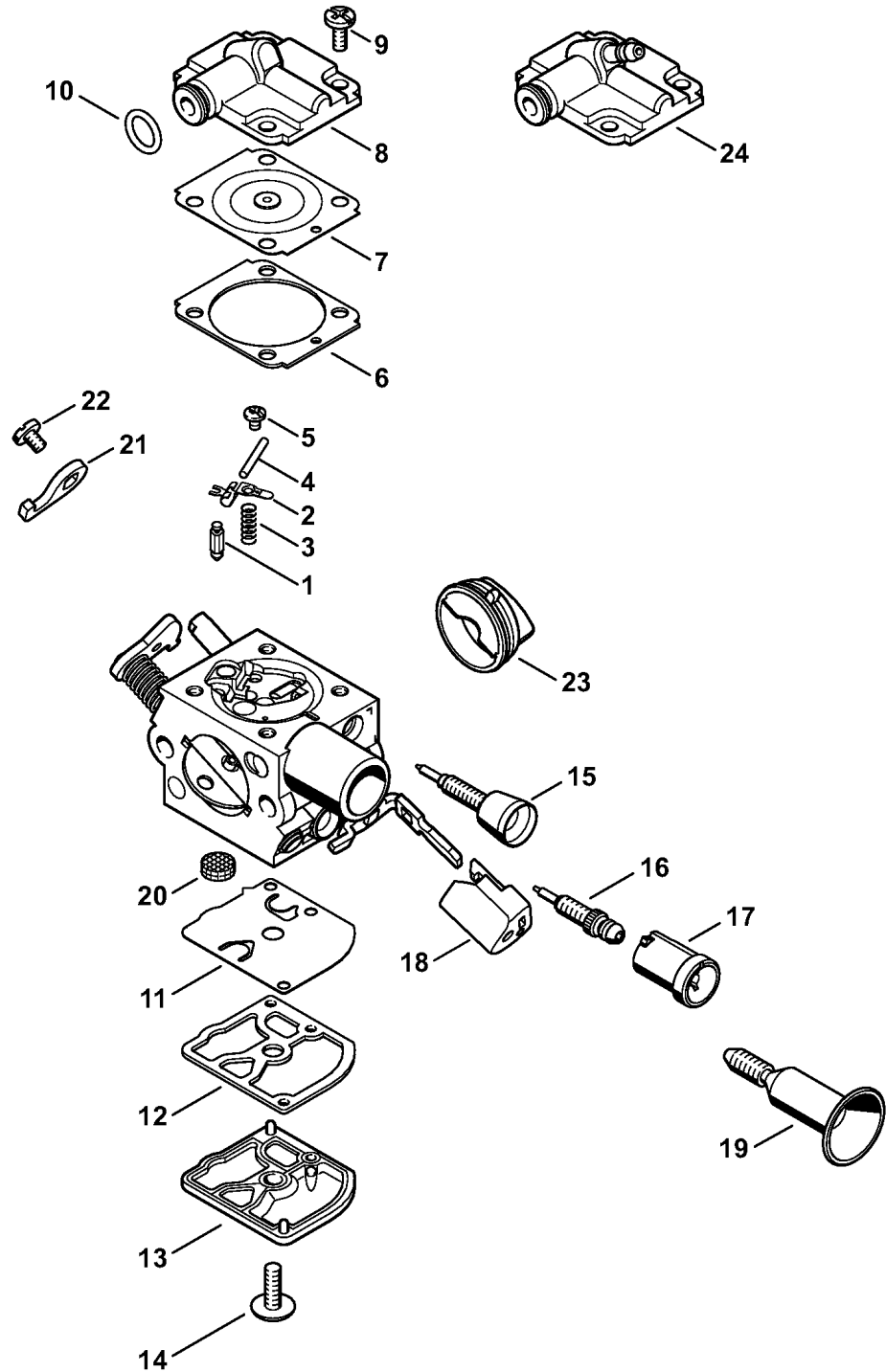

2710ET010.SC

Reference	Item number	Qty	Description
	1141 120 0601	1	Carburetor C1Q-S181A (1,2,4,5) □ 1 - 23
	1141 120 0603	1	Carburetor C1Q-S182A (3,6-9) □ 1 - 7, 9 -24
1	4116 121 5100	1	Inlet needle
2	1125 121 5000	1	Inlet control lever
3	1128 122 3000	1	Spring
4	1120 121 9200	1	Spindle
5	4241 122 6600	1	Collar screw
6	1141 129 0900	1	Gasket
7	1141 121 4700	1	Metering diaphragm
8	1141 121 0800	1	End cover (1,2,4,5)
9	1120 122 6601	4	Collar screw
10	9646 945 0490	1	O-ring 7x1.5
11	1129 121 4800	1	Pump diaphragm
12	1123 129 0905	1	Gasket
13	1139 121 0800	1	End cover
14	1120 122 7800	1	Oval head screw
15	1141 122 6800	1	Low speed adjustment screw
16	1141 122 6700	1	High speed adjustment screw
17	1141 121 2702	1	Cap
18	1141 121 2700	1	Cap
19	1141 122 6200	1	Idle speed adjustment screw
20	1123 121 7800	1	Strainer
21	1141 121 6600	1	Lever
22	9079 319 0280	1	Flat head screw M3x3.5
23	1141 121 9402	1	Ring
24	1141 121 0802	1	End cover (3,6-9)
	1141 007 1006	1	Set of carburetor parts (B) □ 6, 7, 11, 12

(1) MS 271, (2) MS 271-Z, (3) MS 271 C-BE, (4) MS 291, (5) MS 291-Z, (6) MS 291 C-BE, (7) MS 291 C-BE Z, (8) MS 291 C-BEQ, (9) MS 291 C-BEQ Z

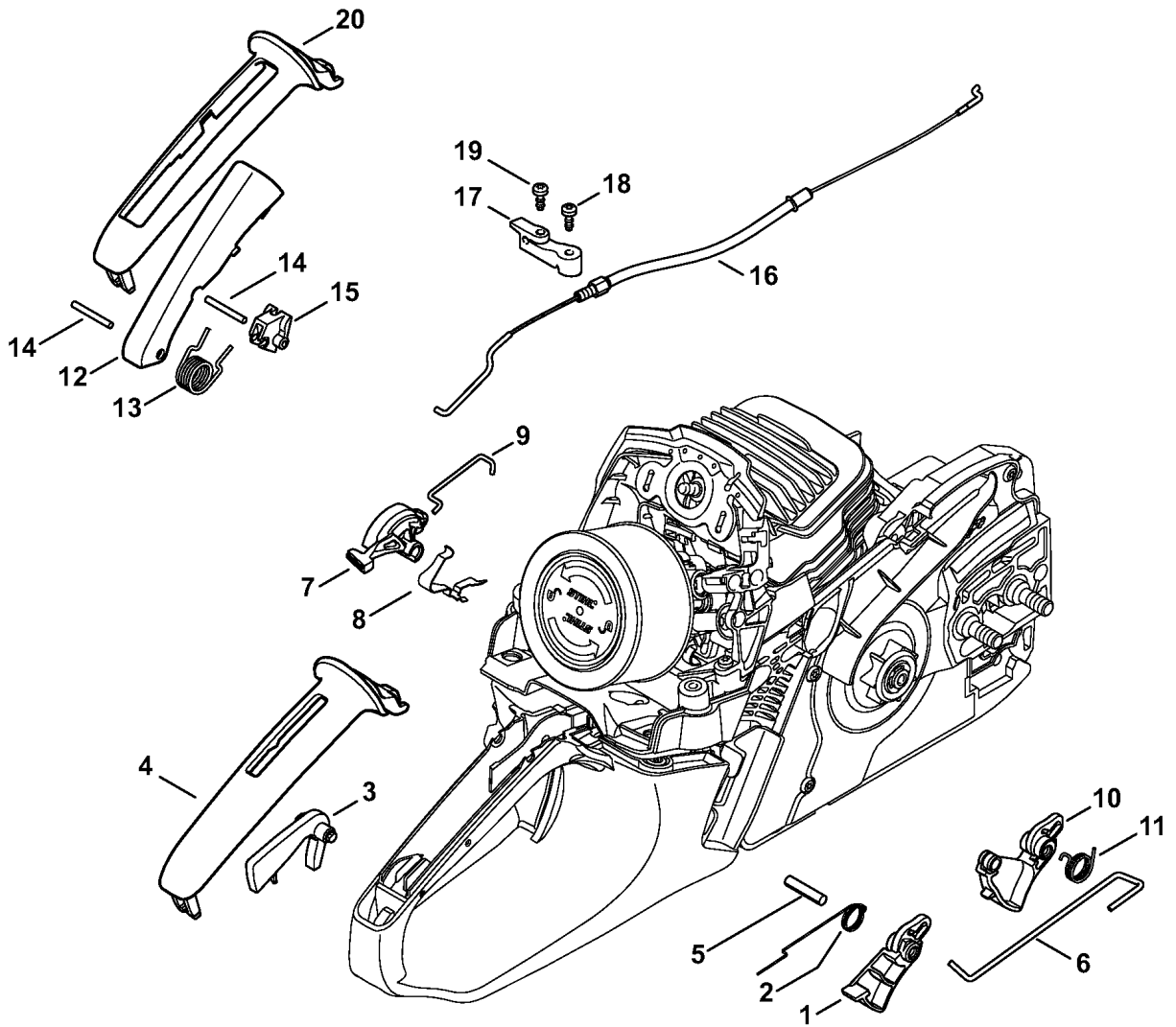

2710ET011 SC

Reference	Item number	Qty	Description
1	1141 182 1000	1	Throttle trigger (1-7)
2	1138 182 4500	1	Torsion spring (1-7)
3	1141 182 0800	1	Trigger interlock (1-7)
4	1141 791 0601	1	Handle molding (1-7)
5	9371 470 2640	1	Cylindrical pin 5x24
6	1141 182 1500	1	Throttle rod
7	1141 182 0900	1	Switch shaft
8	1141 442 1600	1	Contact spring
9	1141 185 1900	1	Choke rod
10	1141 180 1500	1	Throttle trigger (8,9)
11	1141 182 4500	1	Torsion spring (8,9)
12	1125 180 1703	1	Trigger interlock (8,9)
			□ 13
13	1125 182 4502	1	Torsion spring (8,9)
14	9517 003 0650	2	Cylindrical roller 3x25.8 (8,9)
15	1141 180 1400	1	Lever (8,9)
16	1141 160 2500	1	Brake cable (8,9)
			□ 17, 18
17	1141 182 1600	1	Support (8,9)
18	9074 478 2970	1	Pan head self-tapping screw IS-P4x10 (8,9)
19	9074 478 2970	1	Pan head self-tapping screw IS-P4x10 (8,9)
20	1141 791 0603	1	Handle molding (8,9)

(1) MS 271, (2) MS 271-Z, (3) MS 271 C-BE, (4) MS 291, (5) MS 291-Z, (6) MS 291 C-BE, (7) MS 291 C-BE Z, (8) MS 291 C-BEQ, (9) MS 291 C-BEQ Z

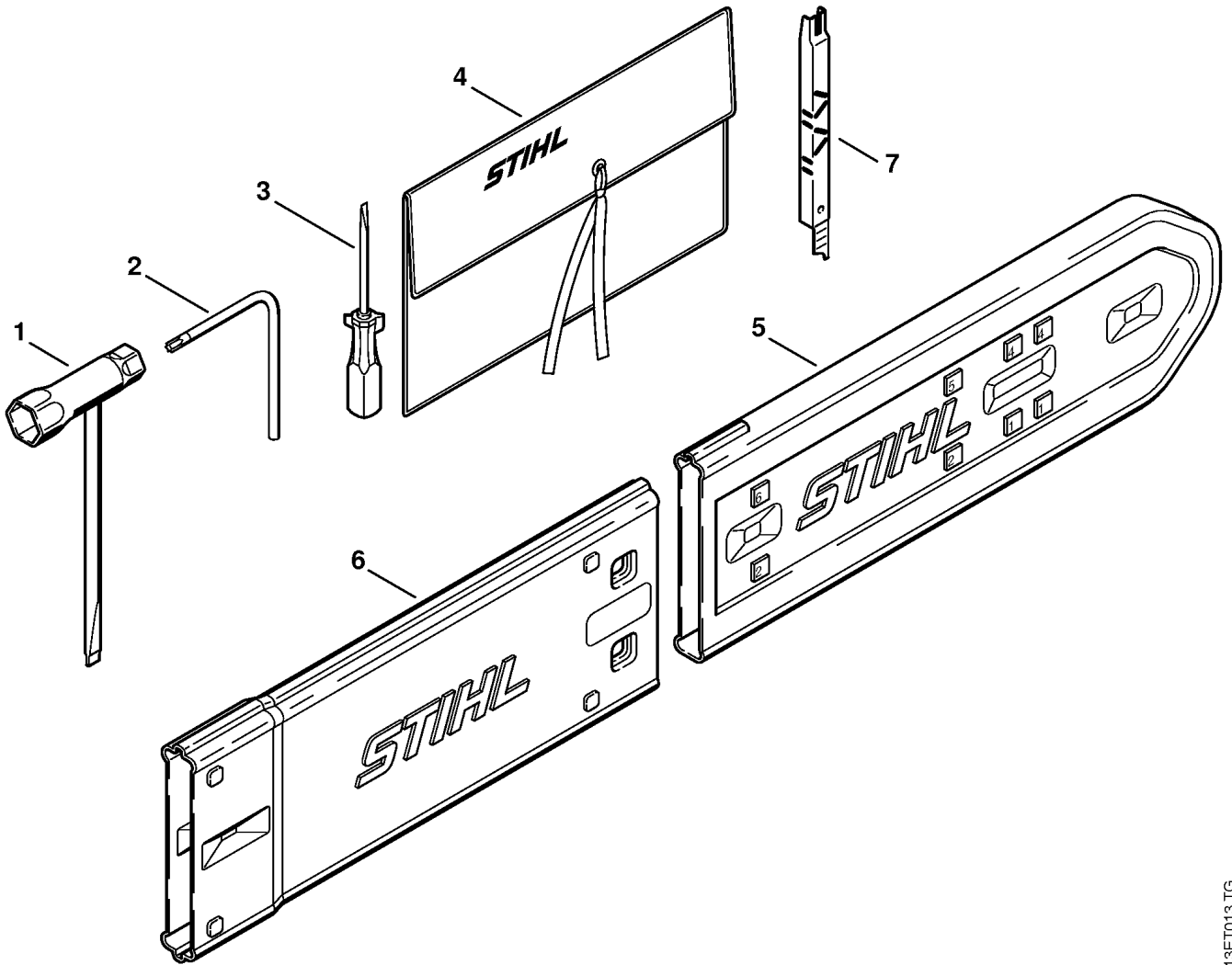

213ET013 TG

Reference	Item number	Qty	Description
1	1129 890 3401	1	Combination wrench
2	0812 370 1000	1	Screwdriver T27x120x70 (B)
3	0000 890 2300	1	Screwdriver
4	0000 891 0801	1	Tool roll (B)
5	0000 792 9129	1	Chain scabbard
6	0000 792 9132	1	Chain scabbard extension up to 63 cm (B)
7	1110 893 4000	1	Filing gauge (B)

(1) MS 271, (2) MS 271-Z, (3) MS 271 C-BE, (4) MS 291, (5) MS 291-Z, (6) MS 291 C-BE, (7) MS 291 C-BE Z, (8) MS 291 C-BEQ, (9) MS 291 C-BEQ Z