

217ET010 SC

Drawing A Cylinder with piston, Ignition system

Reference	Item number	Qty	Description
1	1137 020 1203	1	Cylinder with piston Ø 37 mm (1,2) □ 3 - 6, 12
2	1137 020 1204	1	Cylinder with piston Ø 37 mm (3,4) With pre-exhaust groove □ 3 - 6, 12
3	1137 030 2002	1	Piston Ø 37 mm □ 4 - 6
4	1130 034 3003	2	Piston ring Ø 37x1.2 mm
5	1132 034 1501	1	Piston pin 10x6.5x25
6	9463 650 1000	1	Snap ring 10
7	1137 030 0400	1	Crankshaft (25.2005)
8	1137 036 0300	2	Washer
9	9503 003 0210	2	Grooved ball bearing 6001
10	9639 003 1205	2	Oil seal 12x22x4.5 (02.2005)
10	9639 003 1206	2	Oil seal 12x22x4.5 (02.2005)
11	1137 021 2500	1	Engine pan
12	9075 478 4136	6	Pan head self-tapping screw IS-D5x20
13	1137 140 0600	1	Muffler (1,3)
14	1137 140 0601	1	Muffler (2,4) USA, AUS, CDN □ 15 - 17
15	1137 141 9000	1	Screen (2,4) USA, AUS, CDN
16	1137 140 7400	1	Deflecting plate (2,4) USA, AUS, CDN
17	9099 021 0810	1	Self-tapping screw 4.2x9.5 (2,4) USA, AUS, CDN
18	1137 400 1300	1	Ignition module
19	0000 998 0604	1	Torsion spring
20	1128 405 1000	1	Spark plug boot
21	1137 084 1600	1	Cover
22	0000 989 0507	1	Grommet
23	9075 478 3022	2	Pan head self-tapping screw IS-D4x20
24	9291 021 0100	1	Washer 4.3

(1) MS 192 T, (2) MS 192 T-Z, (3) MS 192 TC-E, (4) MS 192 TC-E Z

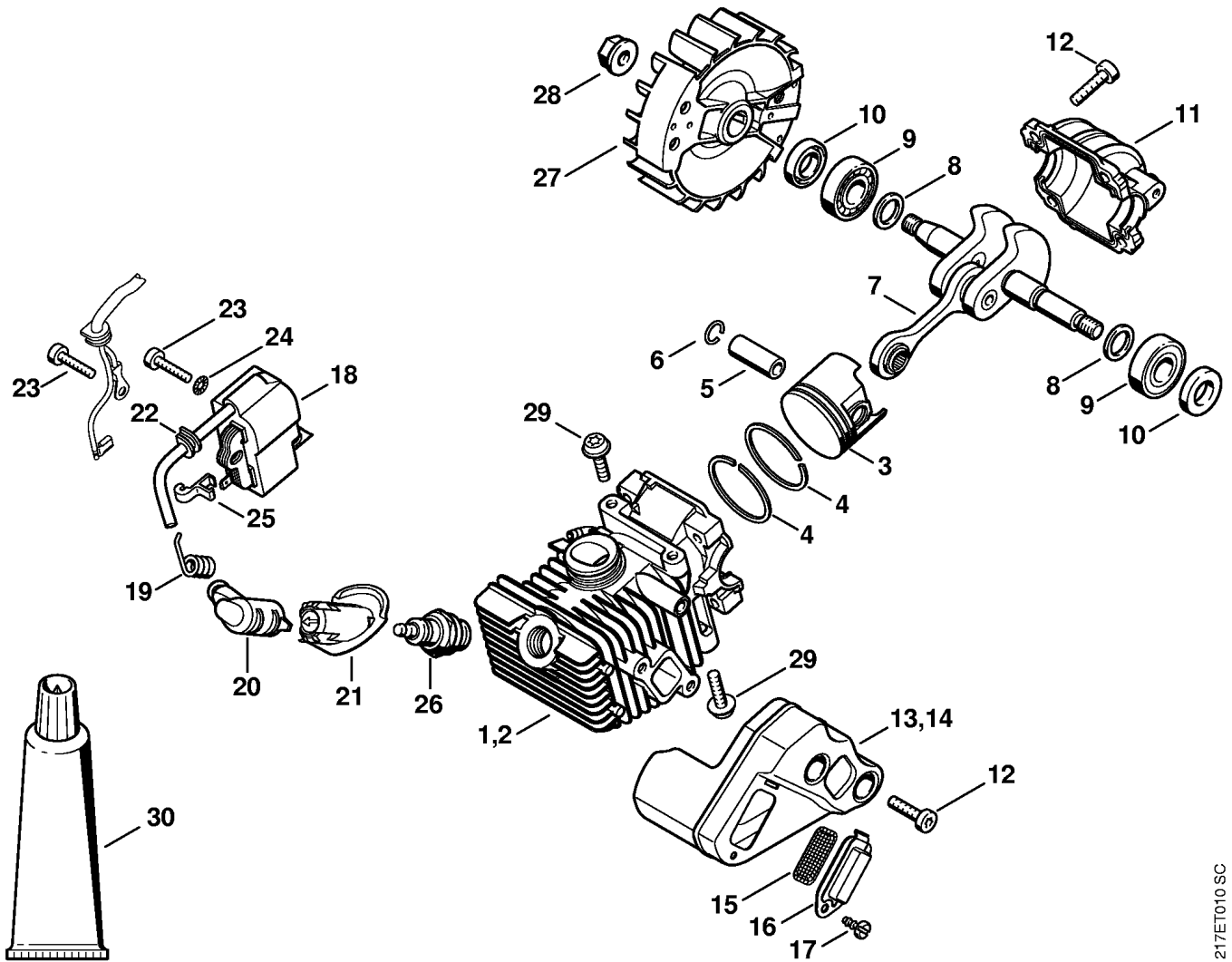

217ET010 SC

Reference	Item number	Qty	Description
25	1137 448 1201	1	Lead retainer
26	0000 400 7000	1	Spark plug NGK BPMR7A
26	1110 400 7005	1	Spark plug Bosch WSR 6 F
27	1137 400 1200	1	Flywheel (25.2005)
28	0000 955 0802	1	Collar nut M8x1
29	0000 951 1100	4	Screw IS-D5x20
30	0783 830 2000	1	Tube of sealant Dirko HT red

(1) MS 192 T, (2) MS 192 T-Z, (3) MS 192 TC-E, (4) MS 192 TC-E Z

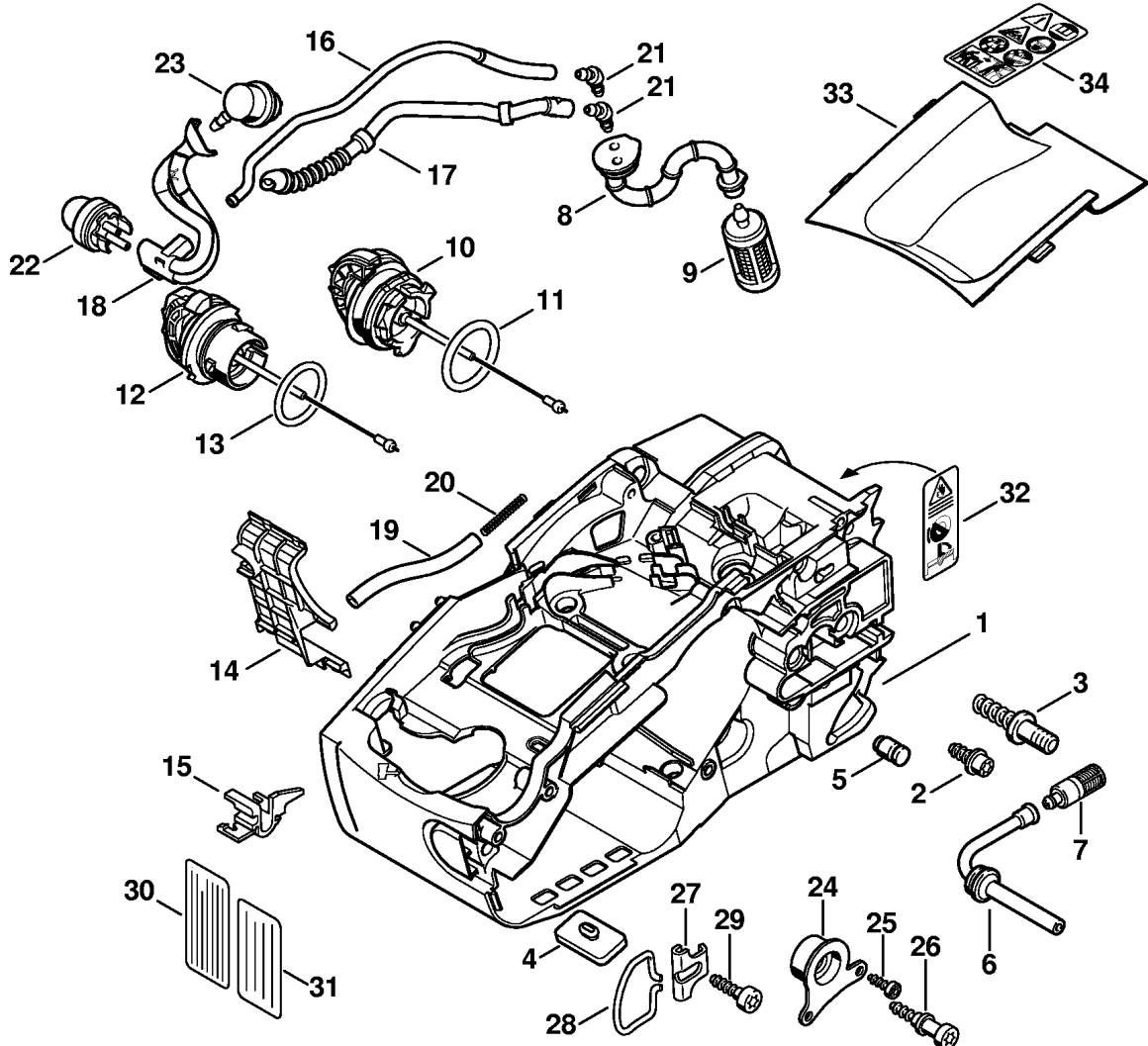

217ET0015 SC

Drawing B Engine housing

Reference	Item number	Qty	Description
1	1137 020 3001	1	Engine housing □ 2 - 9
2	0000 664 2401	1	Collar screw D6
3	1123 664 2400	1	Collar screw
4	1129 352 5500	1	Clamp
5	1128 640 9100	1	Valve
6	1129 647 9400	1	Hose
7	1123 640 3800	1	Pickup body
8	1137 358 7700	1	Hose
9	0000 350 3502	1	Pickup body
10	0000 350 0525	1	Filler cap □ 11
11	9645 948 7734	1	O-ring 25x3.5
12	0000 350 0526	1	Filler cap □ 13
13	9645 948 2470	1	O-ring 23x3
14	1137 351 4000	1	Insulating plate
15	1137 028 1500	1	Support
16	1137 350 5000	1	Tube □ 21
17	1137 358 7701	1	Hose
18	1137 358 7702	1	Hose
19		1	Hose 3.1x5.7x82 mm (D)
	0000 930 2803	1	Hose 3.1x5.7 mm x 1 m (A,B)
20	0000 997 2003	1	Compression spring
21	1137 353 2600	2	Elbow connector
22	4130 350 6200	1	Fuel pump
23	0000 350 5802	1	Tank vent
24	1137 790 9900	1	Annular buffer
25	9074 477 2995	2	Pan head self-tapping screw IS-P4x12
26	1129 791 6100	1	Screw
27	1129 352 7700	1	Bracket
28	1129 352 5000	1	Loop
29	9074 478 4435	1	Pan head self-tapping screw IS-P6x19
30	0000 967 3501	1	Instruction label (2,4) USA
31	0000 967 3685	1	Instruction label (1) BR
32	0000 967 3605	1	Warning pictogram Filler cap (2,4) USA, CDN

(1) MS 192 TC-E, (2) MS 192 TC-E Z, (3) MS 192 TC-E Z, (4) MS 192 TC-E Z

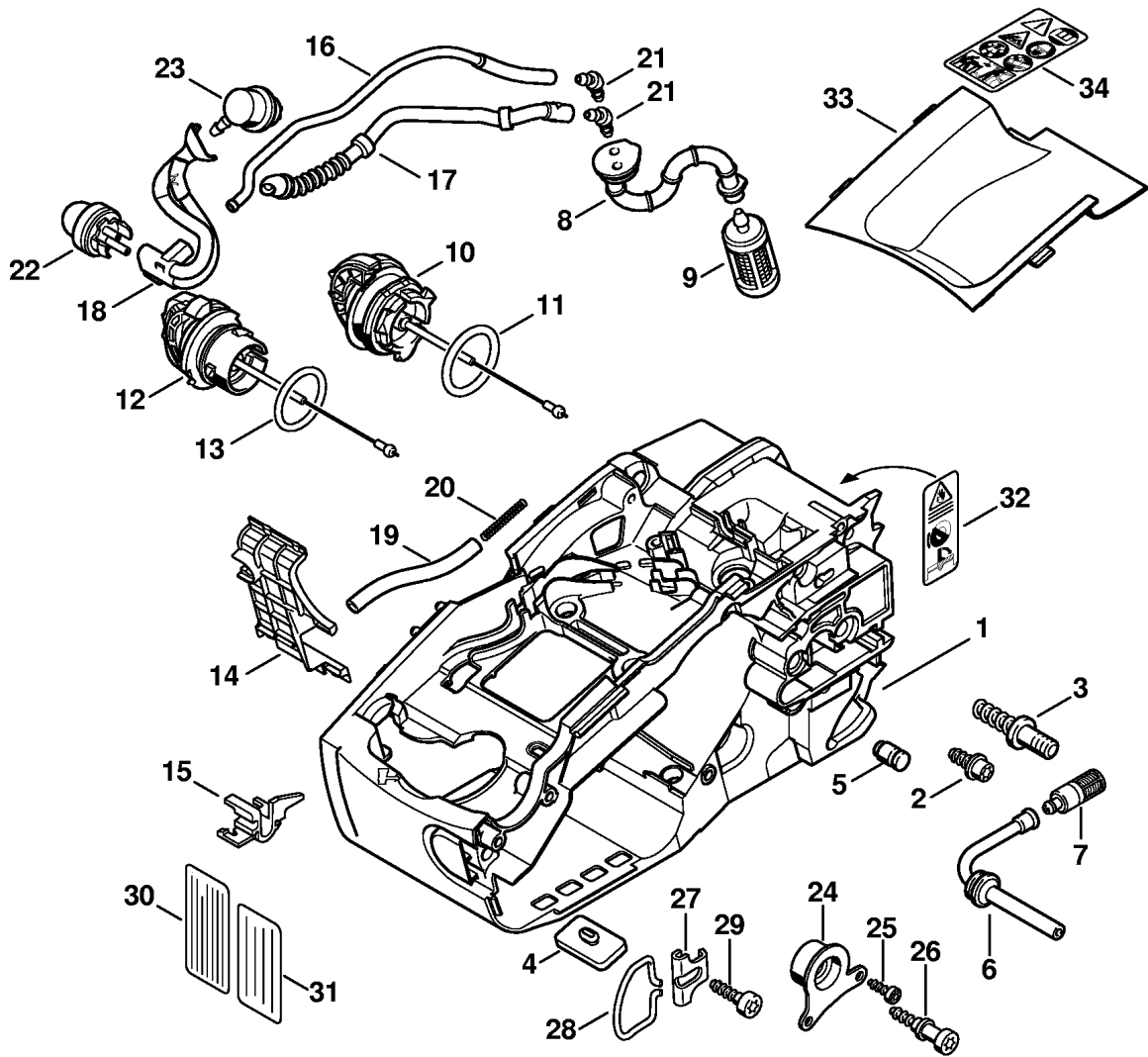

217ET0015 SC

Reference	Item number	Qty	Description
34	1129 967 3403	1	Instruction label

(1) MS 192 T, (2) MS 192 T-Z, (3) MS 192 TC-E, (4) MS 192 TC-E Z

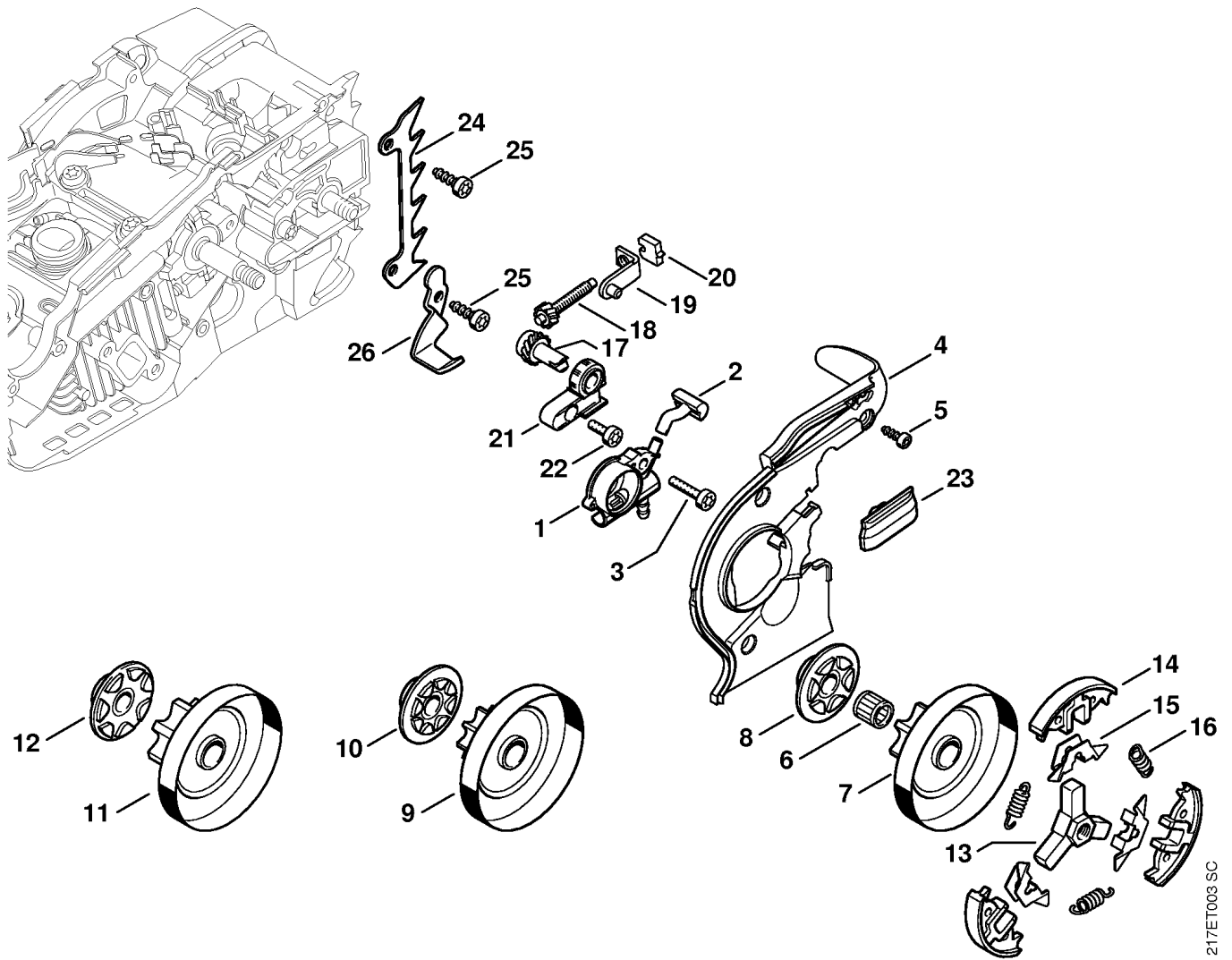

217ET003 SC

Reference	Item number	Qty	Description
1	1137 640 3202	1	Oil pump □ 2
2	1137 647 5701	1	Connector
3	9075 478 3022	1	Pan head self-tapping screw IS-D4x20
4	1137 021 1100	1	Cover
5	9074 477 2995	3	Pan head self-tapping screw IS-P4x12
6	9512 933 2270	1	Needle cage 10x13x13
7	1137 640 2001	1	Chain sprocket 3/8" Picco 6T
8	1129 640 7100	1	Worm 3/8" Picco 6T
	1137 007 1002	1	Set of spur sprocket/worm 1/4" 8T
9	1137 640 2002	1	Chain sprocket 1/4" 8T not for USA
10	1129 640 7102	1	Worm 1/4" 8T
11	1137 640 2003	1	Chain sprocket 3/8" Picco 7T (B)
12	1129 640 7101	1	Worm 3/8" Picco 7T (B)
13	1137 160 2000	1	Clutch □ 14 - 16
14	1137 162 0800	3	Clutch shoe
15	1121 162 3000	3	Retainer
16	0000 997 5625	3	Tension spring
	1129 007 1000	1	Spur gear / chain adjusting screw kit □ 17, 18
17		1	Spur gear (D)
18		1	Adjusting screw (D)
19	1129 640 1900	1	Tensioner slide
20	1123 664 1400	1	Thrust pad
21	1123 664 2200	1	Cover
22	9075 478 3015	1	Pan head self-tapping screw IS-D4x15
23	1123 648 6600	2	Bumper strip
24	1129 664 0500	1	Bumper spike (B)
25	9074 477 4130	2	Pan head self-tapping screw IS-P5x16 (B)
26	1129 656 7701	1	Chain catcher (B)

(1) MS 192 T, (2) MS 192 T-Z, (3) MS 192 TC-E, (4) MS 192 TC-E Z

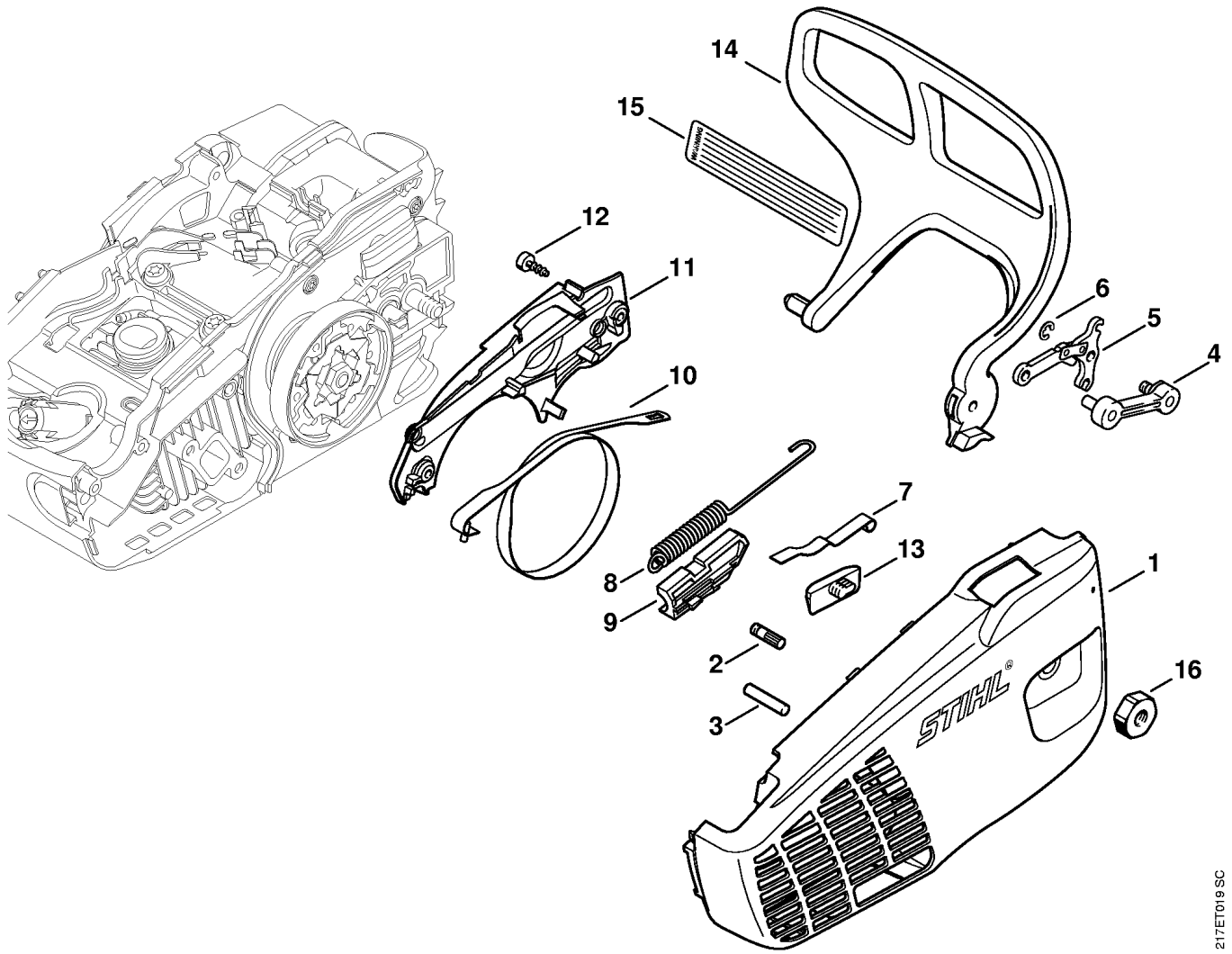

217ET019 SC

Drawing D Chain sprocket cover

Reference	Item number	Qty	Description
	1137 640 1700	1	Chain sprocket cover □ 1 - 14
1	1137 640 1701	1	Chain sprocket cover □ 2 - 4
2	1120 162 5200	1	Pin
3	9378 543 2700	1	Notched pin 5x30
4	1129 640 5000	1	Insert
5	1128 160 5000	1	Lever
6	9460 624 0400	1	E-clip 4
7	1129 162 7800	1	Flat spring
8	1137 160 5502	1	Tension spring □ 9
9	1137 162 6600	1	Limit stop
10	1123 160 5400	1	Brake band
11	1137 648 7700	1	Cover
12	9074 477 2995	2	Pan head self-tapping screw IS-P4x12
13	1123 648 6600	1	Bumper strip
14	1137 792 9100	1	Hand guard
15	0000 967 3724	1	Instruction label (2,4) USA
16	0000 955 0801	1	Hexagon nut M8

(1) MS 192 T, (2) MS 192 T-Z, (3) MS 192 TC-E, (4) MS 192 TC-E Z

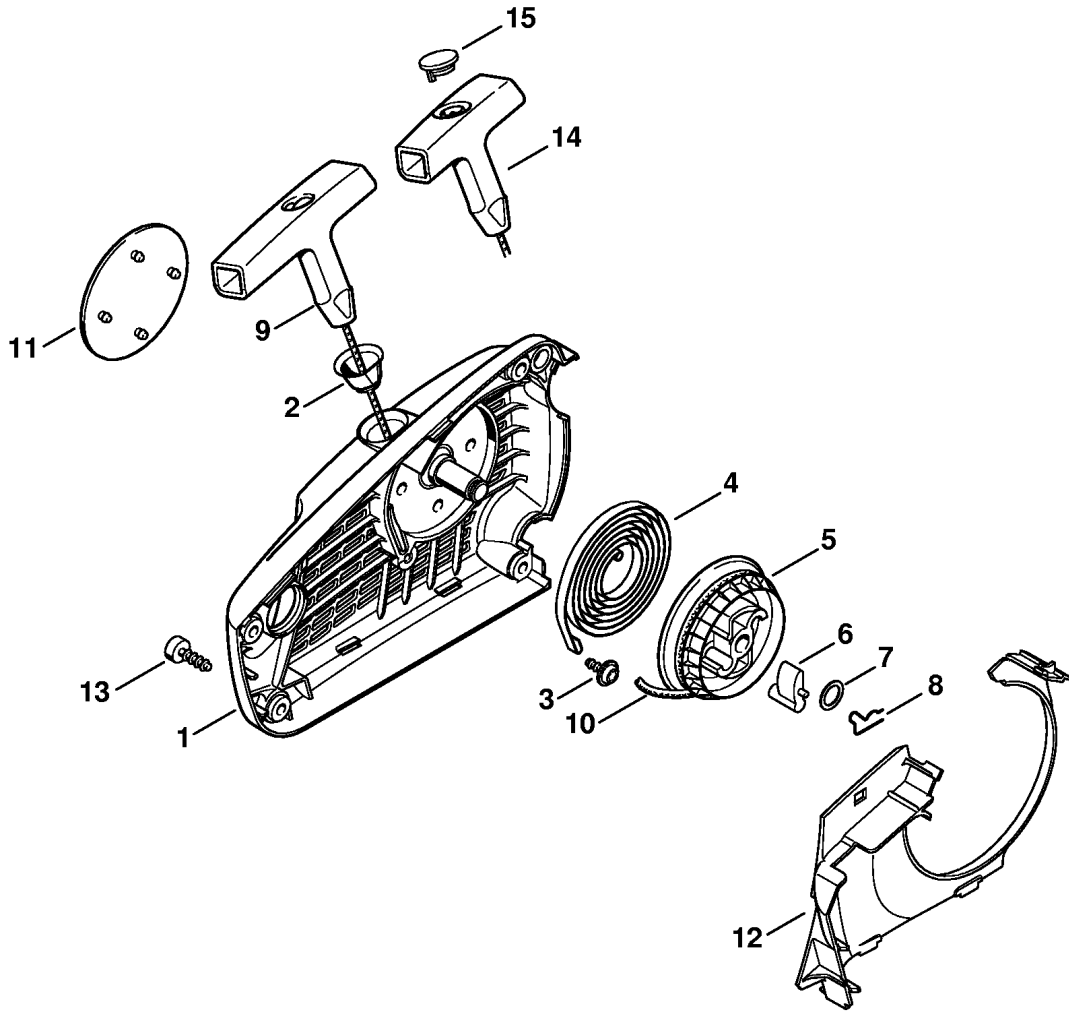

217ET018 SC

Reference	Item number	Qty	Description
	1137 080 2100	1	Fan housing with rewind starter (1,2) □ 1 - 12
1	1137 080 1800	1	Fan housing (1,2) □ 2, 3
2	1110 084 9102	1	Bushing (1,2)
3	9104 003 2960	1	Self-tapping screw P4x10 (1,2)
4	1123 190 0600	1	Rewind spring (1,2)
5	1123 195 0400	1	Rope rotor (1,2)
6	1125 195 7200	1	Pawl (1,2)
7	0000 958 0923	1	Washer (1,2)
8	1118 195 3500	1	Spring (1,2)
9	1121 195 3400	1	Starter grip (1,2)
10	0000 195 8200	1	Starter rope Ø 3x800 mm (1,2)
11	1137 967 1500	1	Model plate MS 192 T (1,2)
12	1137 084 7800	1	Segment (1,2)
13	9074 477 4130	4	Pan head self-tapping screw IS-P5x16 (1,2)
14	0000 190 3402	1	Starter grip ElastoStart Ø 3 mm (B) (1,2) □ 10, 15
15	0000 195 7001	1	Cap (B) (1,2)

(1) MS 192 T, (2) MS 192 T-Z, (3) MS 192 TC-E, (4) MS 192 TC-E Z

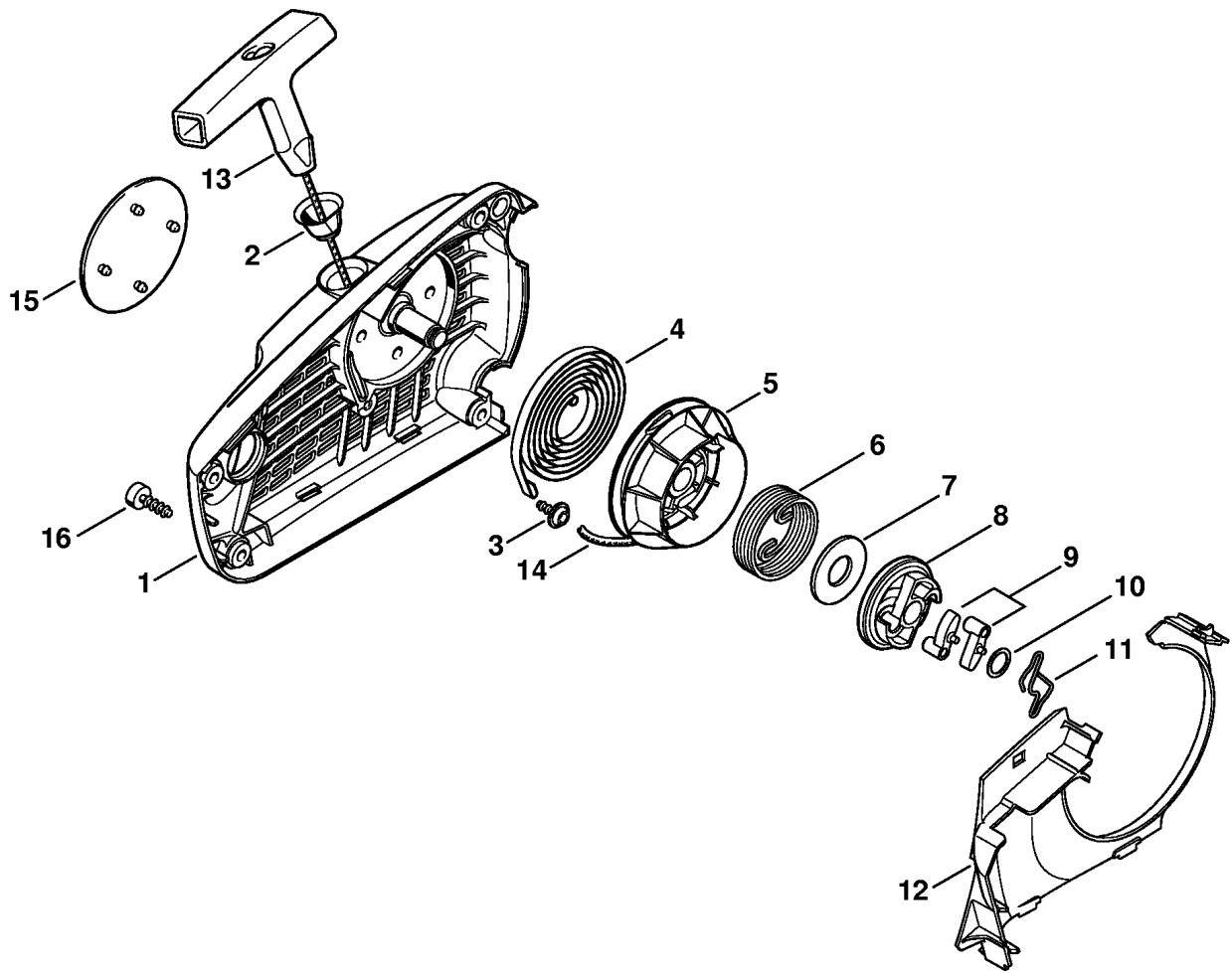

151ET010 SC

Reference	Item number	Qty	Description
	1137 080 2105	1	Fan housing with rewind starter (3,4) □ 1 - 14
1	1137 080 1801	1	Fan housing (3,4) □ 2, 3
2	1110 084 9102	1	Bushing (3,4)
3	9104 003 2960	1	Self-tapping screw P4x10 (3,4)
4	1123 190 0600	1	Rewind spring (3,4)
5	1137 190 1000	1	Rope rotor (3,4) □ 6 - 8
6	1137 195 3501	1	Spring (3,4)
7	0000 958 1020	1	Washer (3,4)
8		1	Carrier (D) (3,4)
9	1123 195 7200	2	Pawl (3,4)
10	0000 958 0923	1	Washer (3,4)
11	1128 195 3500	1	Spring (3,4)
12	1137 084 7800	1	Segment (3,4)
13	1121 195 3400	1	Starter grip (3,4)
14	0000 195 8204	1	Starter rope Ø 2.7x800 mm (3,4)
15	1137 967 1503	1	Model plate MS 192 TC (3,4)
16	9074 477 4130	4	Pan head self-tapping screw IS-P5x16 (3,4)

(1) MS 192 T, (2) MS 192 T-Z, (3) MS 192 TC-E, (4) MS 192 TC-E Z

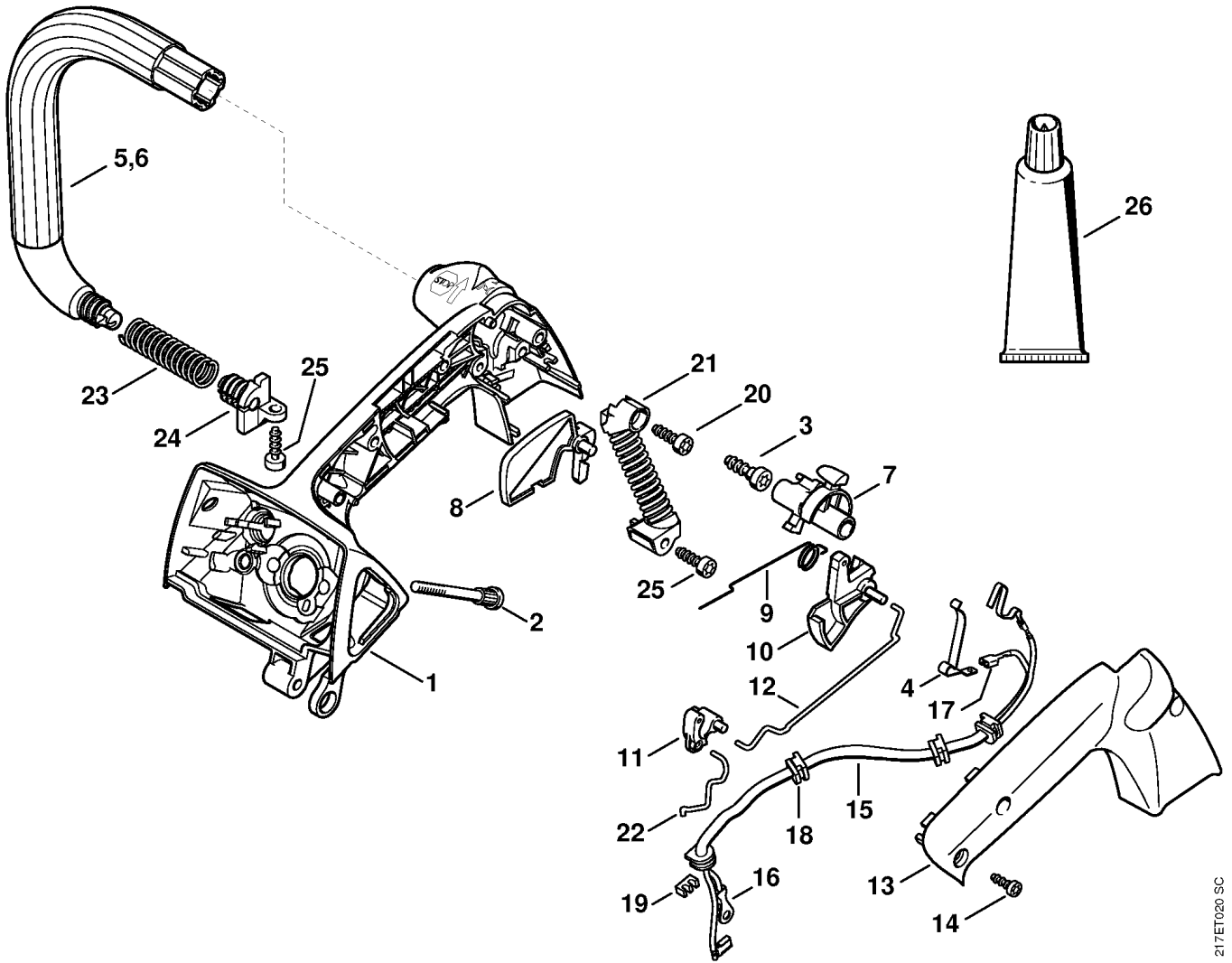

217ET020 SC

Drawing G Handle housing

Reference	Item number	Qty	Description
	1137 790 1001	1	Handle housing (1,2) □ 1-5, 7-18, 20, 21
	1137 790 1004	1	Handle housing (3,4) □ 1-4, 6-18, 20, 21
1	1137 790 1000	1	Handle housing □ 2
2	1121 122 6600	2	Collar screw
3	9074 478 4435	1	Pan head self-tapping screw IS-P6x19
4		1	Contact spring (D) (21.2008)
5	1137 791 1700	1	Handlebar (1,2)
6	1137 791 1702	1	Handlebar (3,4)
7	1137 180 0950	1	Switch shaft (21.2008) □ 4
8	1137 182 0800	1	Trigger interlock
9	1129 182 4500	1	Torsion spring
10	1132 180 1500	1	Throttle trigger
11	1129 180 4000	1	Double lever
12	1129 182 1501	1	Throttle rod
13	1137 791 0600	1	Handle molding
14	9074 477 2995	3	Pan head self-tapping screw IS-P4x12
15	1137 440 3000	1	Wiring harness □ 16 - 19
16	0751 030 8950	1	Terminal socket A 4-1
17	0751 030 8953	1	Terminal socket 4.8-1
18	0000 989 0507	4	Grommet
19	1137 448 1200	1	Lead retainer
20	9074 477 4130	1	Pan head self-tapping screw IS-P5x16
21	1137 790 8300	1	AV-Spring
22	1137 182 1500	1	Throttle rod
23	1137 791 3101	1	Spring
24	1137 792 2902	1	Bearing plug
25	9074 477 4130	2	Pan head self-tapping screw IS-P5x16
26	0781 120 1109	1	Gear lubricant 80 g (B) (21.2008)

(1) MS 192 T, (2) MS 192 T-Z, (3) MS 192 TC-E, (4) MS 192 TC-E Z

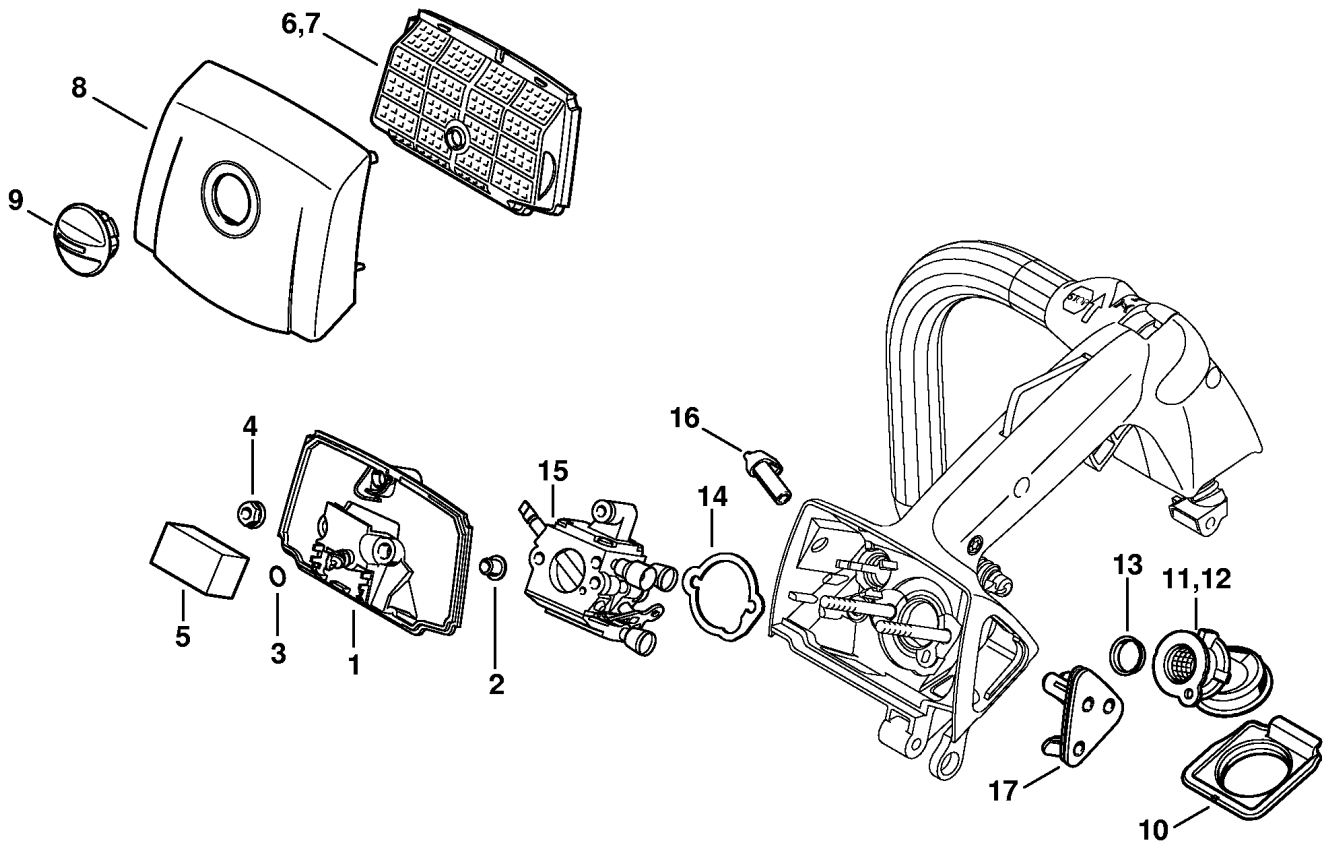

217ET0013 SC

Reference	Item number	Qty	Description
1	1137 120 3400	1	Filter base □ 2, 3
2	9416 868 6531	2	Hollow rivet 6.5x0.5x6.8
3	9645 945 7444	1	O-ring 4x1.5
4	9216 261 0700	2	Hexagon nut M5
5	1129 122 0100	1	Foam insert
6	1137 120 1600	1	Air filter, fleece
7	1137 120 1601	1	Air filter
8	1137 140 1900	1	Carburetor box cover □ 9
9	1137 140 9200	1	Twist lock
10	1137 141 3300	1	Supporting plate
11	1137 141 2201	1	Manifold → 271 210 654
12 *	1137 141 2200	1	Manifold (13.2007)
13	1137 141 1800	1	Sleeve
14	1129 121 8600	1	Washer
15	1137 120 0600	1	Carburetor C1Q-S134
15	1137 120 0602	1	Carburetor C1Q-S135
15	1137 120 0605	1	Carburetor C1Q-S125 BR
16	1137 121 6100	1	Choke lever
17	1137 123 7500	1	Grommet

(1) MS 192 T, (2) MS 192 T-Z, (3) MS 192 TC-E, (4) MS 192 TC-E Z

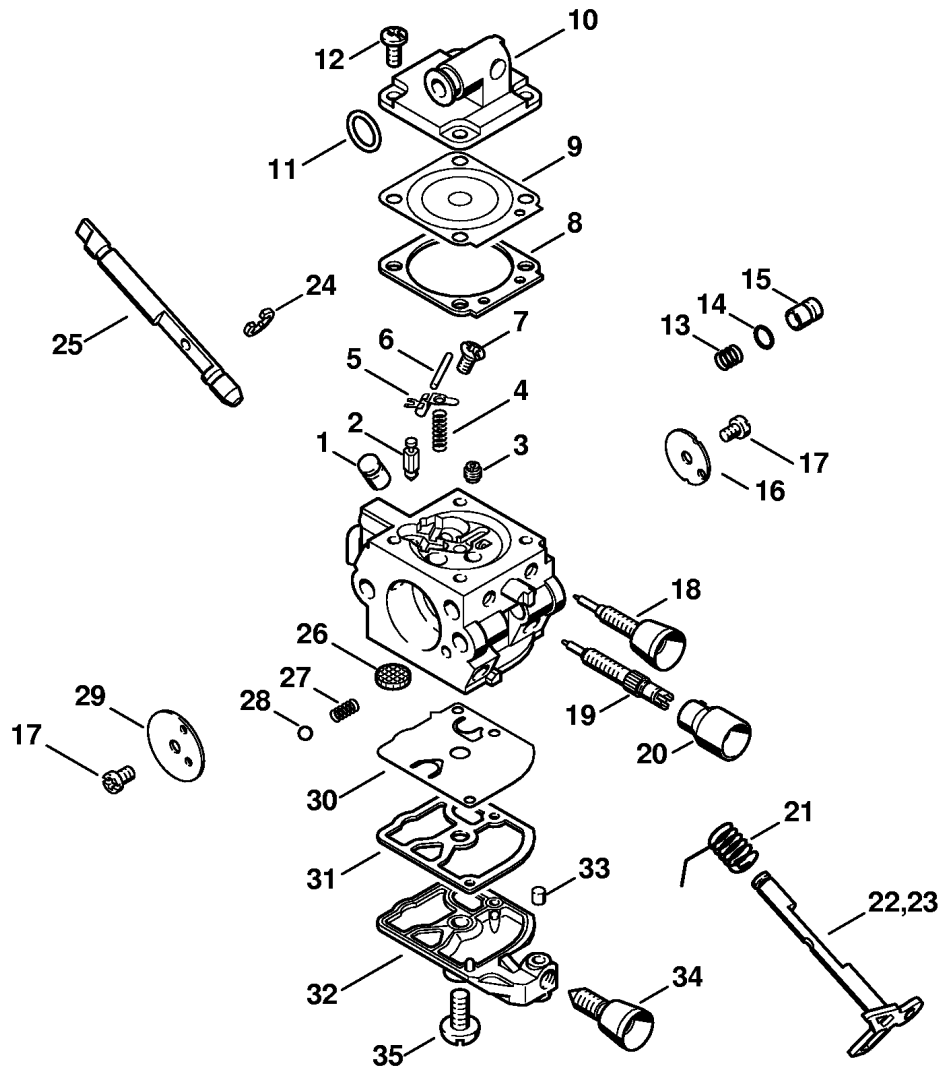

217E1017 SC

Reference	Item number	Qty	Description
	1137 120 0600	1	Carburetor C1Q-S134 □ 1-22,24-35
	* 1137 120 0600	1	Carburetor C1Q-S103 (C) (13.2007) □ 1-21,23-35
1	1137 121 5400	1	Valve jet
2	4116 121 5100	1	Inlet needle
3	4228 121 5602	1	Fixed jet 0.39
4	1128 122 3000	1	Spring
5	1125 121 5000	1	Inlet control lever
6	1120 121 9200	1	Spindle
7	1120 122 6600	1	Collar screw
8	1129 129 0900	1	Gasket
9	4129 121 4700	1	Metering diaphragm
10	1130 121 0800	1	End cover
11	9646 945 0490	1	O-ring 7x1.5
12	1120 122 6601	4	Collar screw
	1137 120 9704	1	Pump piston kit □ 13 - 15
	* 1137 120 9700	1	Pump piston kit (13.2007) □ 13 - 15
13		1	Spring (D)
14		1	Sealing ring (D)
15		1	Pump piston (D)
16	1137 121 3300	1	Throttle shutter
17	1125 122 7403	2	Round head screw
18	1137 122 6800	1	Low speed adjustment screw
19	1137 122 6700	1	High speed adjustment screw
20	4229 121 2701	1	Cap
21	1123 122 3000	1	Spring
22	1137 120 7104	1	Throttle shaft with lever
23	* 1137 120 7100	1	Throttle shaft with lever (13.2007)

(1) 124, 192 1125 122 9001-Z, (3) 1E-clip 2 TC-E, (4) MS 192 TC-E Z

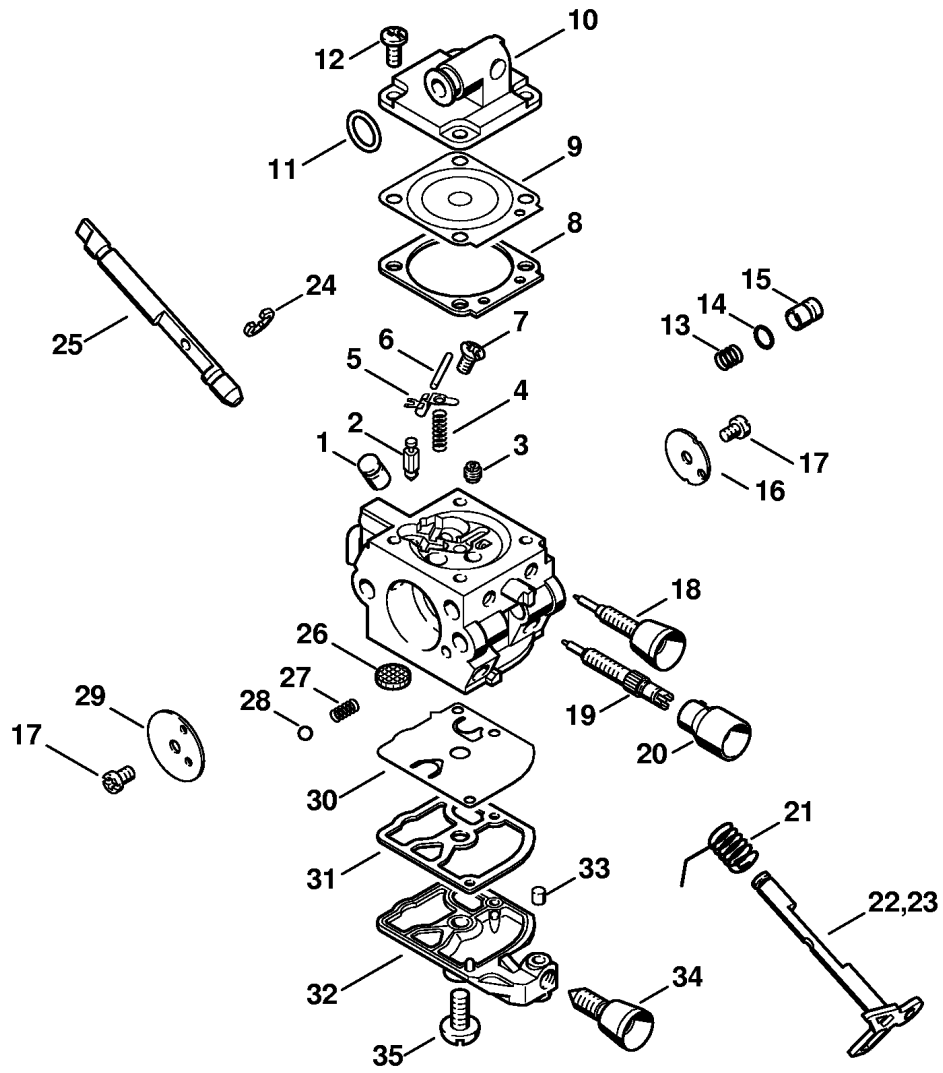

217ET017 SC

Reference	Item number	Qty	Description
25	1137 121 3000	1	Choke shaft
26	1123 121 7800	1	Strainer
27	4119 122 3002	1	Spring
28	4119 122 4200	1	Ball
29	1129 121 2900	1	Choke shutter
30	1129 121 4800	1	Pump diaphragm
31	1123 129 0905	1	Gasket
32	1137 121 0800	1	End cover
33	1125 122 4200	1	Ball
34	4229 122 6200	1	Idle speed adjustment screw
35	1120 122 7800	1	Oval head screw
	1129 007 1062	1	Set of carburetor parts □ 8, 9, 30, 31

(1) MS 192 T, (2) MS 192 T-Z, (3) MS 192 TC-E, (4) MS 192 TC-E Z

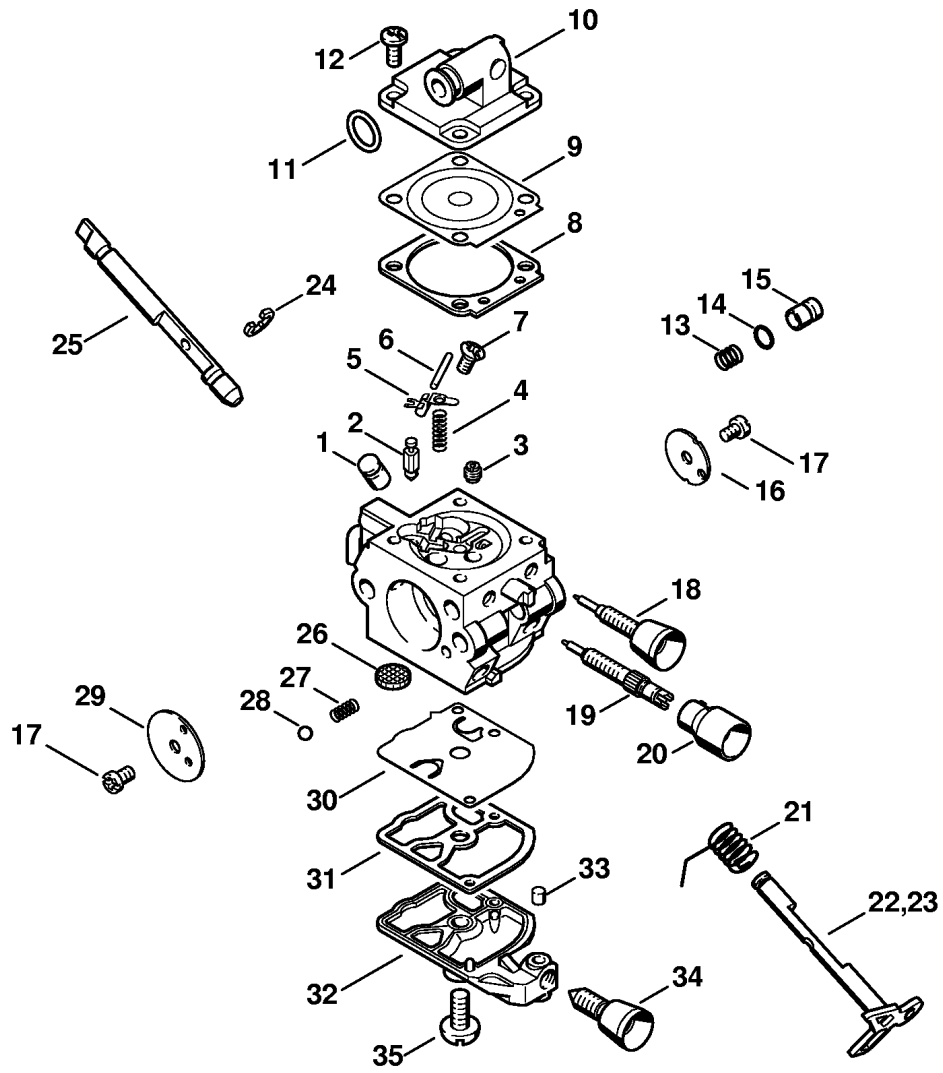

217E1017 SC

Reference	Item number	Qty	Description
	1137 120 0602	1	Carburetor C1Q-S135 □ 1-22,24-35
		1	Carburetor C1Q-S104 (C) (13.2007) □ 1-21,23-35
1	1137 121 5400	1	Valve jet
2	4116 121 5100	1	Inlet needle
3	4228 121 5602	1	Fixed jet 0.39
4	1128 122 3000	1	Spring
5	1125 121 5000	1	Inlet control lever
6	1120 121 9200	1	Spindle
7	1120 122 6600	1	Collar screw
8	1129 129 0900	1	Gasket
9	4129 121 4700	1	Metering diaphragm
10	1130 121 0800	1	End cover
11	9646 945 0490	1	O-ring 7x1.5
12	1120 122 6601	4	Collar screw
	1137 120 9704	1	Pump piston kit □ 13 - 15
	* 1137 120 9700	1	Pump piston kit (13.2007) □ 13 - 15
13		1	Spring (D)
14		1	Sealing ring (D)
15		1	Pump piston (D)
16	1137 121 3301	1	Throttle shutter
17	1125 122 7403	2	Round head screw
18	4314 122 6801	1	Low speed adjustment screw
19	1137 122 6700	1	High speed adjustment screw
20	4229 121 2701	1	Cap
21	1123 122 3000	1	Spring
22	1137 120 7104	1	Throttle shaft with lever
23	* 1137 120 7100	1	Throttle shaft with lever (13.2007)
24	1125 122 9001	1	E-clip
(1) 125, 192	1137 121 3000-Z, (3)	1	Choke shaft-, (4) MS 192 TC-E Z

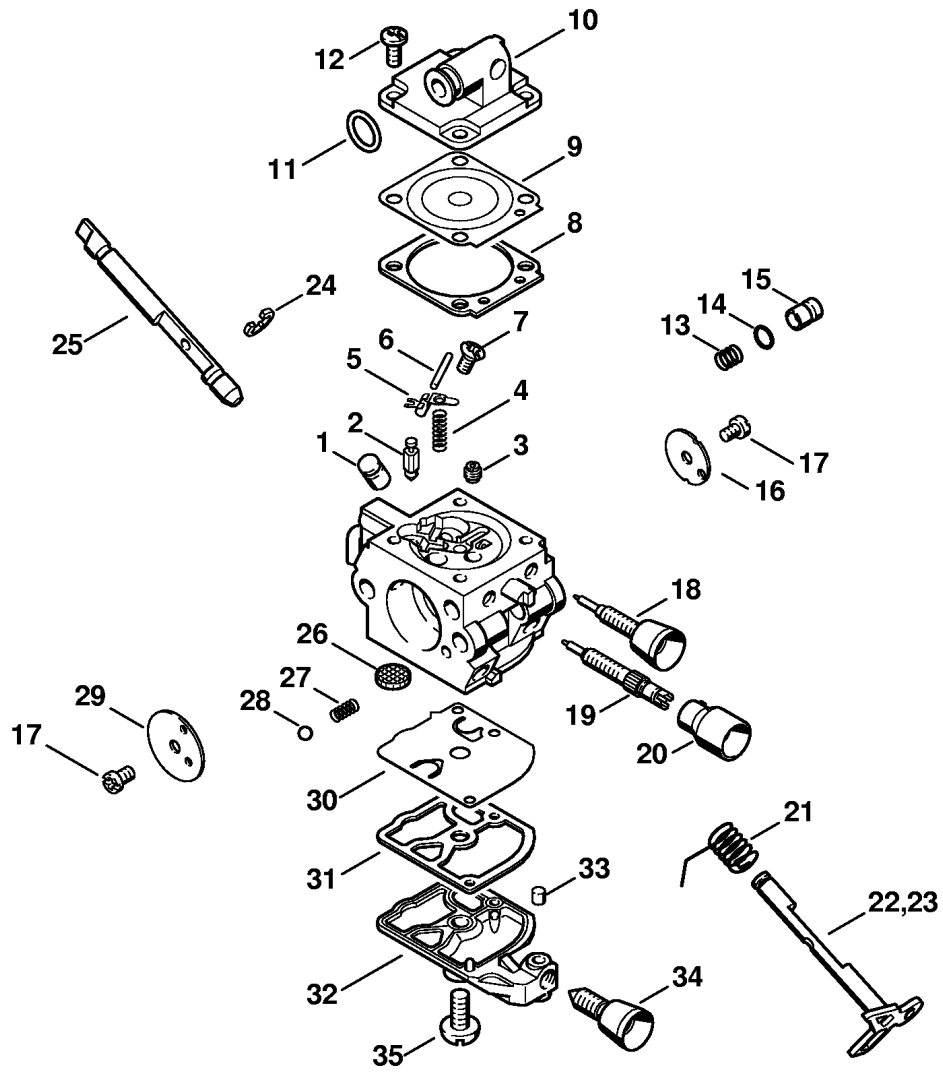

217E1017 SC

Reference	Item number	Qty	Description
26	1123 121 7800	1	Strainer
27	4119 122 3002	1	Spring
28	4119 122 4200	1	Ball
29	1129 121 2900	1	Choke shutter
30	1129 121 4800	1	Pump diaphragm
31	1123 129 0905	1	Gasket
32	1137 121 0800	1	End cover
33	1125 122 4200	1	Ball
34	4229 122 6200	1	Idle speed adjustment screw
35	1120 122 7800	1	Oval head screw
	1129 007 1062	1	Set of carburetor parts □ 8, 9, 30, 31

(1) MS 192 T, (2) MS 192 T-Z, (3) MS 192 TC-E, (4) MS 192 TC-E Z

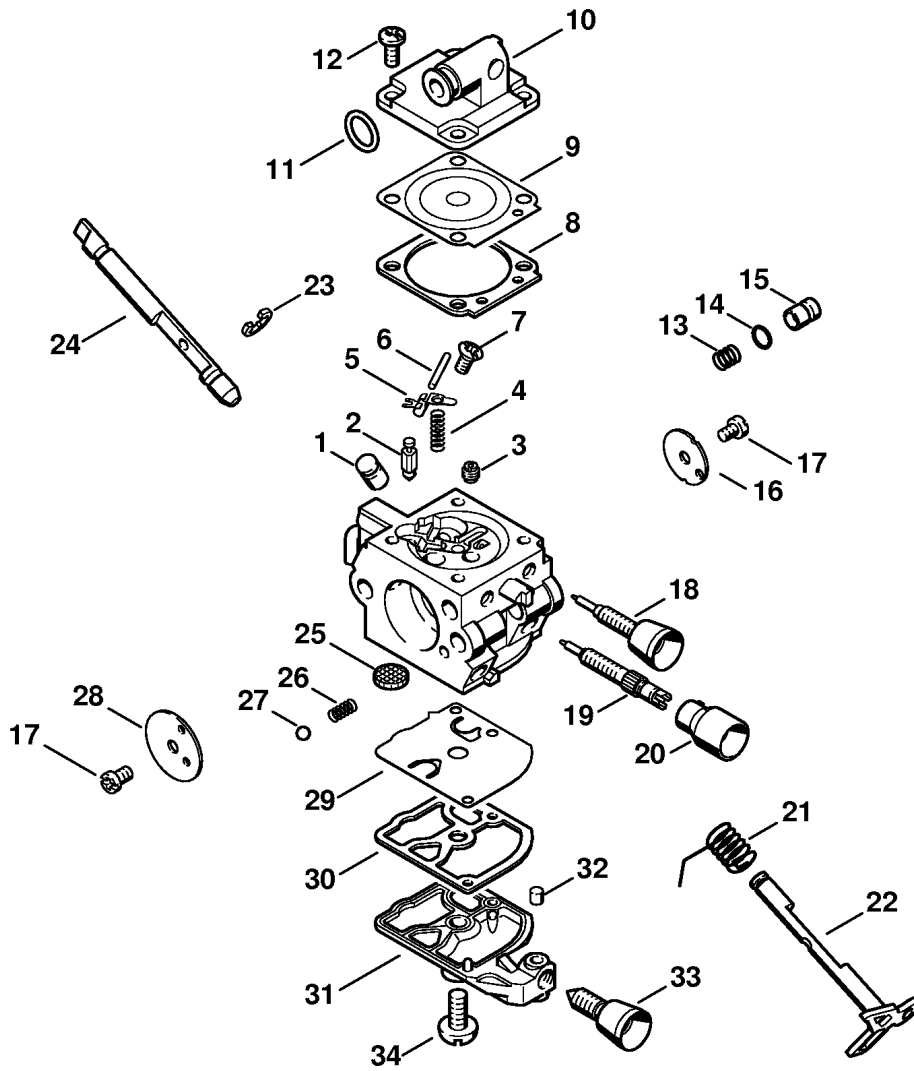

217ET000 SC

Reference	Item number	Qty	Description
	1137 120 0605	1	Carburetor C1Q-S125 □ 1 - 34
1	1137 121 5400	1	Valve jet
2	4116 121 5100	1	Inlet needle
3	4228 121 5602	1	Fixed jet 0.39
4	1128 122 3000	1	Spring
5	1125 121 5000	1	Inlet control lever
6	1120 121 9200	1	Spindle
7	1120 122 6600	1	Collar screw
8	1129 129 0900	1	Gasket
9	4129 121 4700	1	Metering diaphragm
10	1130 121 0800	1	End cover
11	9646 945 0490	1	O-ring 7x1.5
12	1120 122 6601	4	Collar screw
	1137 120 9704	1	Pump piston kit □ 13 - 15
13		1	Spring (D)
14		1	Sealing ring (D)
15		1	Pump piston (D)
16	1137 121 3300	1	Throttle shutter
17	1125 122 7403	2	Round head screw
18	1137 122 6800	1	Low speed adjustment screw
19	1137 122 6700	1	High speed adjustment screw
20	4229 121 2701	1	Cap
21	1123 122 3000	1	Spring
22	1137 120 7104	1	Throttle shaft with lever
23	1125 122 9001	1	E-clip
24	1137 121 3000	1	Choke shaft
25	1123 121 7800	1	Strainer
26	4119 122 3002	1	Spring
27	4119 122 4200	1	Ball
28	1129 121 2900	1	Choke shutter
29	1129 121 4800	1	Pump diaphragm
30	1123 129 0905	1	Gasket
31	1137 121 0800	1	End cover
32	1125 122 4200	1	Ball
33	4229 122 6200	1	Idle speed adjustment screw
34	1120 122 7800	1	Oval head screw
	1129 007 1062	1	Set of carburetor parts

(1) MS 192 T, (2) MS 192 T-Z, (3) □ 8, 9, 29, 30 (4) MS 192 TC-E Z

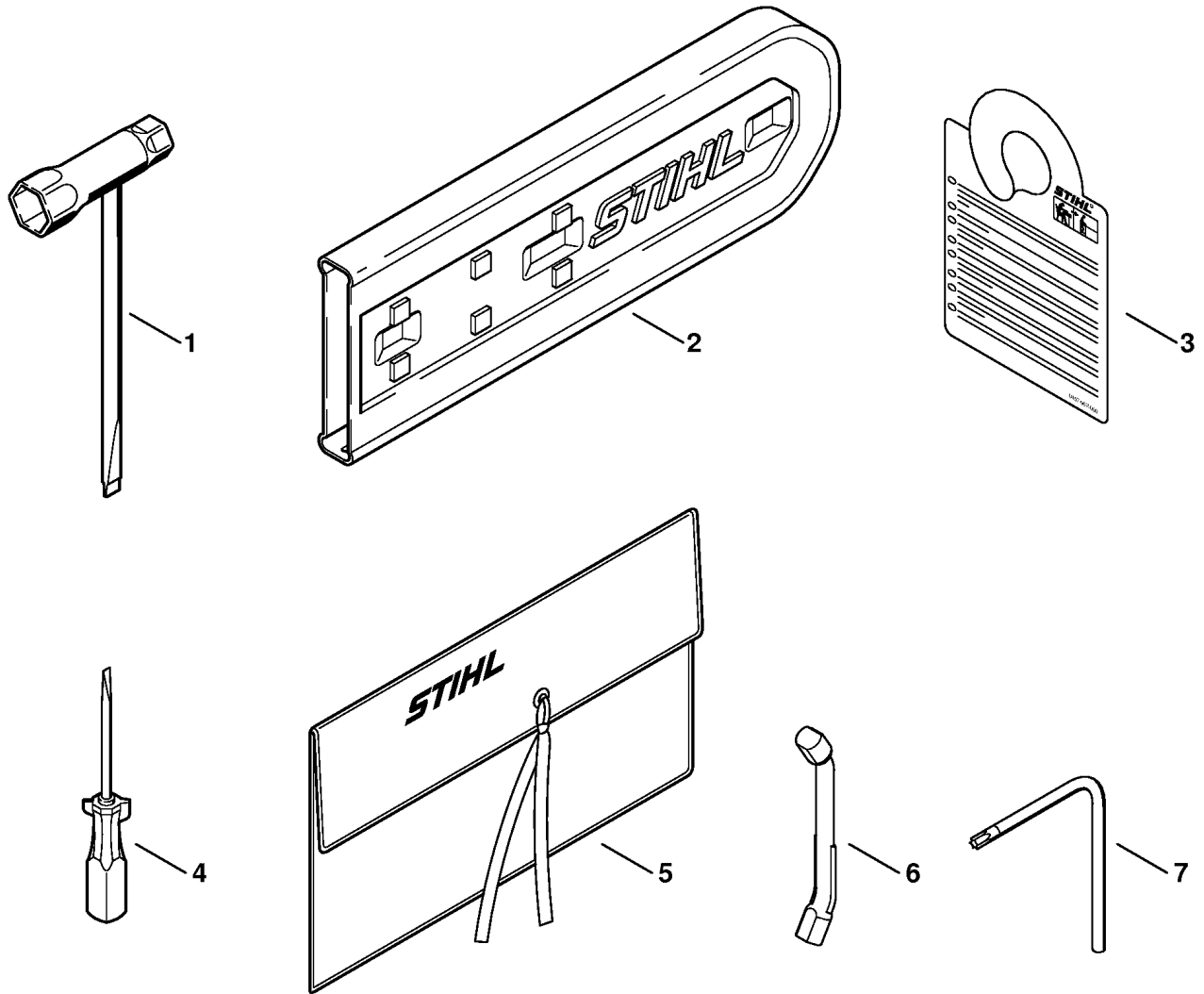

217ET009 SC

Reference	Item number	Qty	Description
1	1129 890 3401	1	Combination wrench
2	0000 792 9128	1	Chain scabbard
3	0457 927 0000	1	Tag
4	0000 890 2300	1	Screwdriver
4	0000 890 2305	1	Screwdriver available in Brazil only
5	0000 891 0801	1	Tool roll (B)
6	0000 893 5903	1	Locking strip
7	0812 370 1000	1	Screwdriver T27x120x70

(1) MS 192 T, (2) MS 192 T-Z, (3) MS 192 TC-E, (4) MS 192 TC-E Z