

# ***PARTNER***

Illustrated Parts List 2000-05 cd

***K700 ACTIVE*** 1994-1996

***K700 ACTIVE II*** 1997-2000

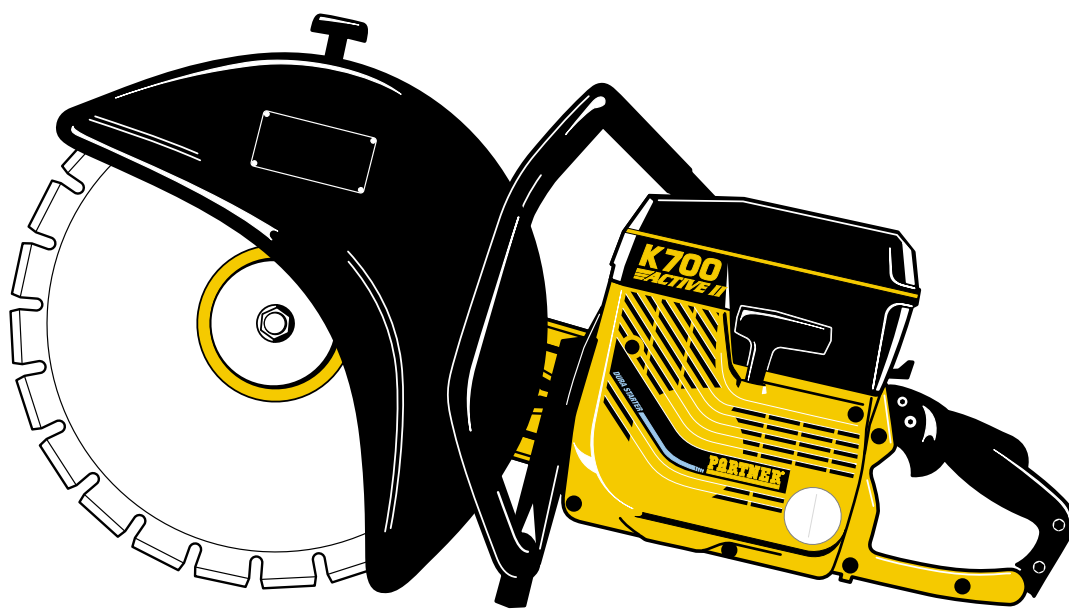

108 30 00-43

---

**PARTNER®**

**A**

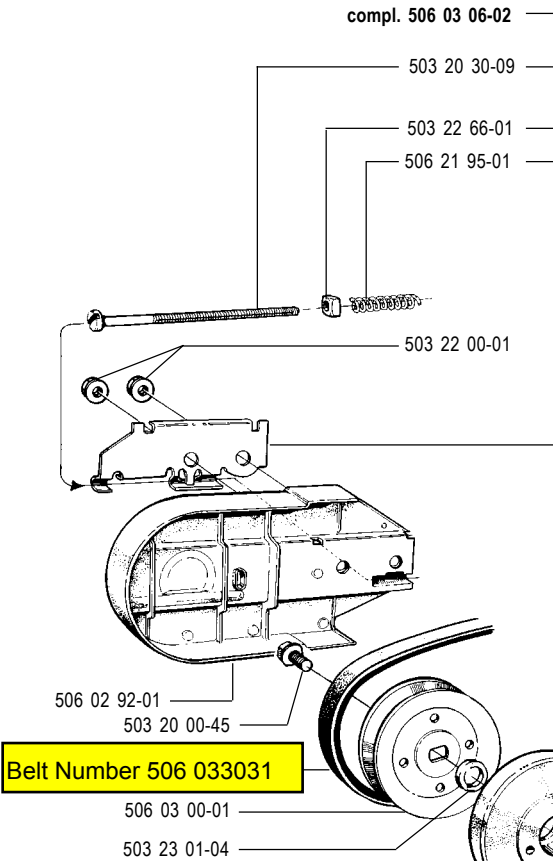

**B**

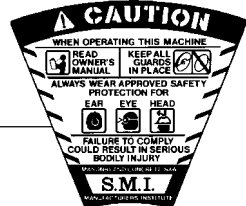
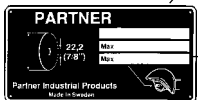
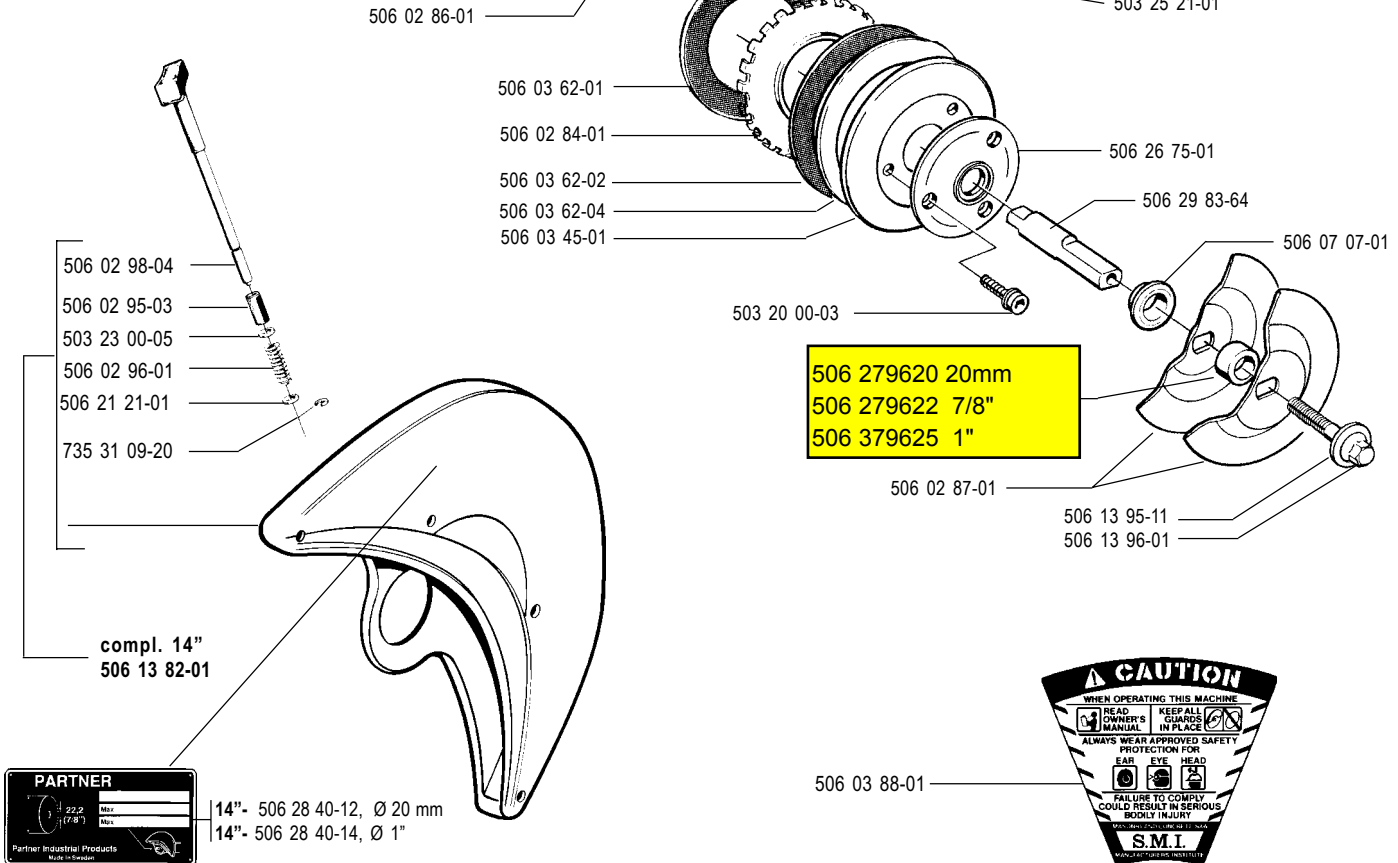
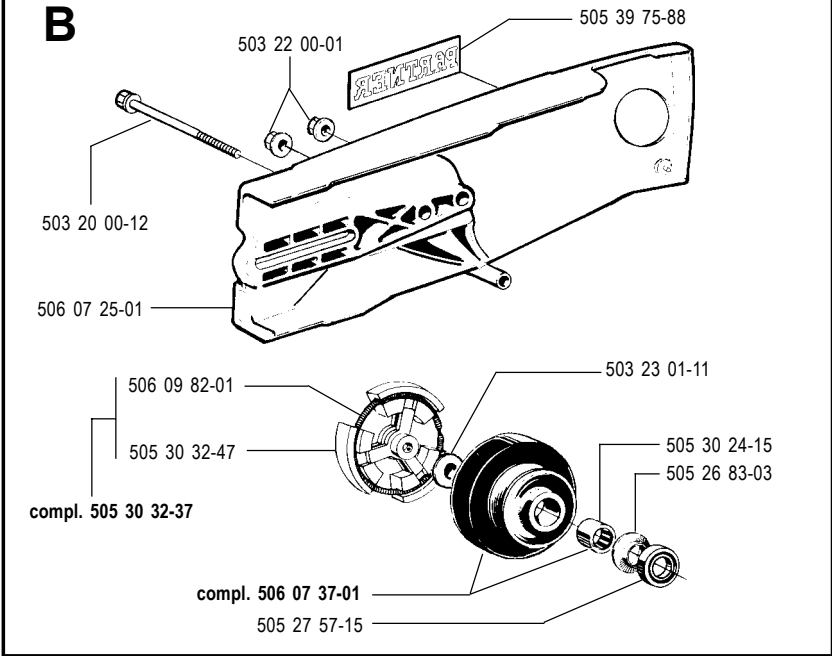

C

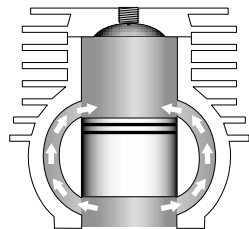
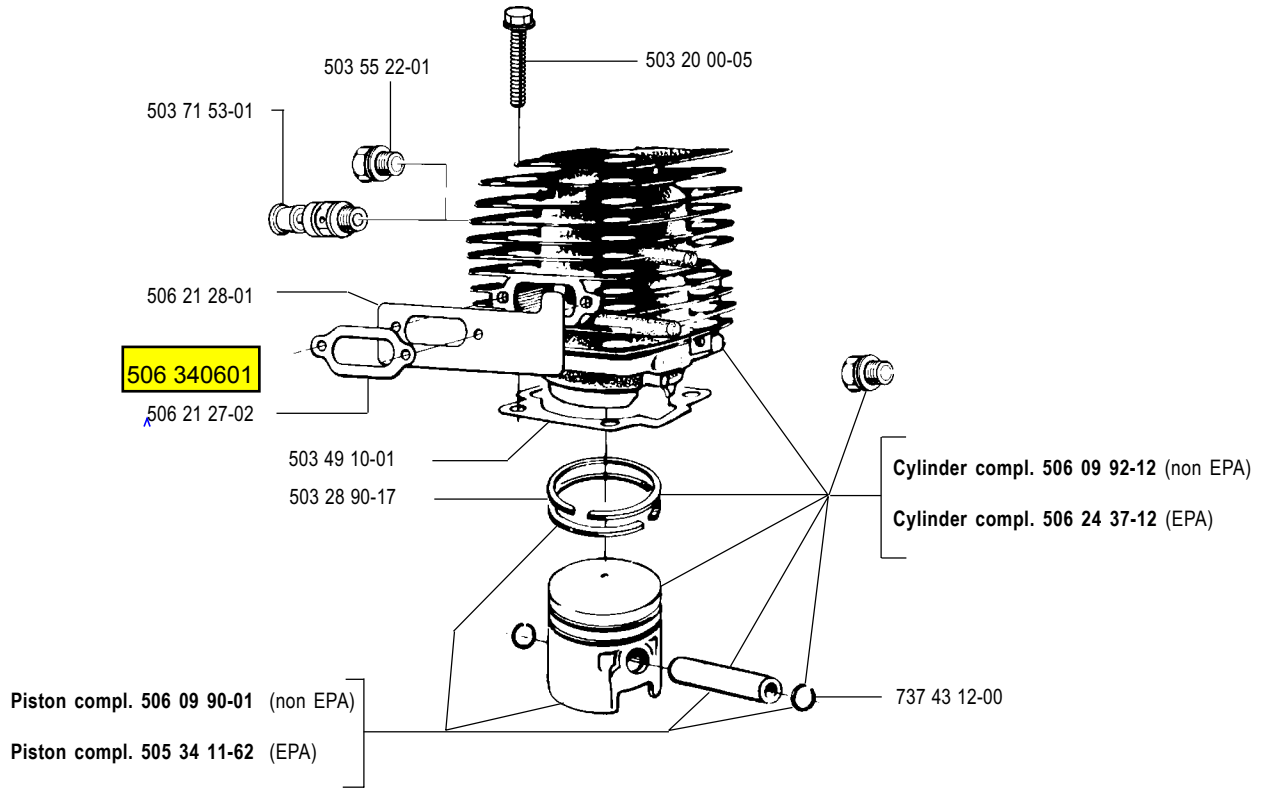

"EPA" Style

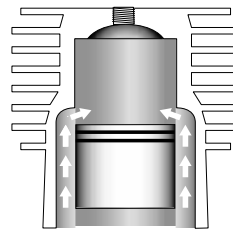

"Non EPA" Style

D

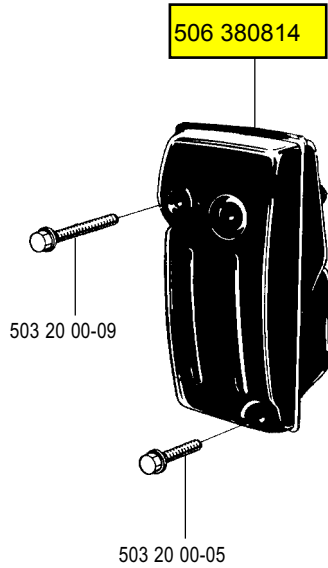

E

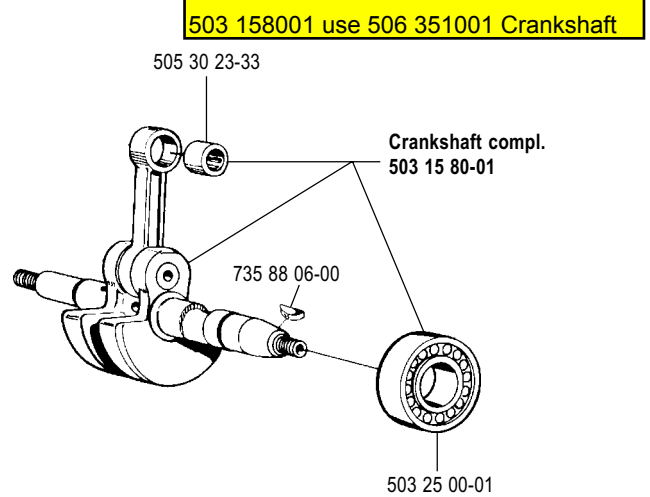

**Note:** When installing, place the tapered side of the inside bearing race towards the counter weight.

# F

**"SmartCarb"**  
 Proper Adjustment  
 L = 1-11/8  
 H = 3/4-7/8

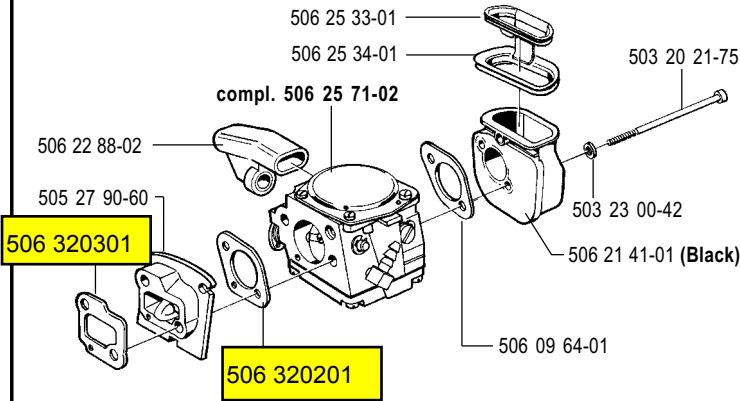

**"SmartCarb"**  
 Fixed jet carburetor ("EPA")

**Note:** Use only on saws equipped with Green Ignition System

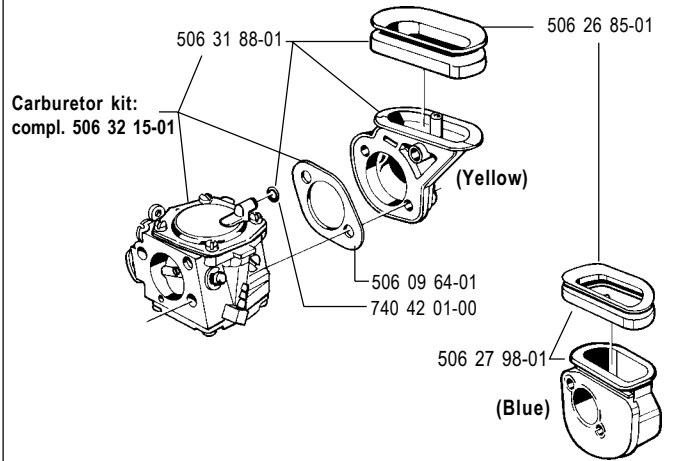

# G

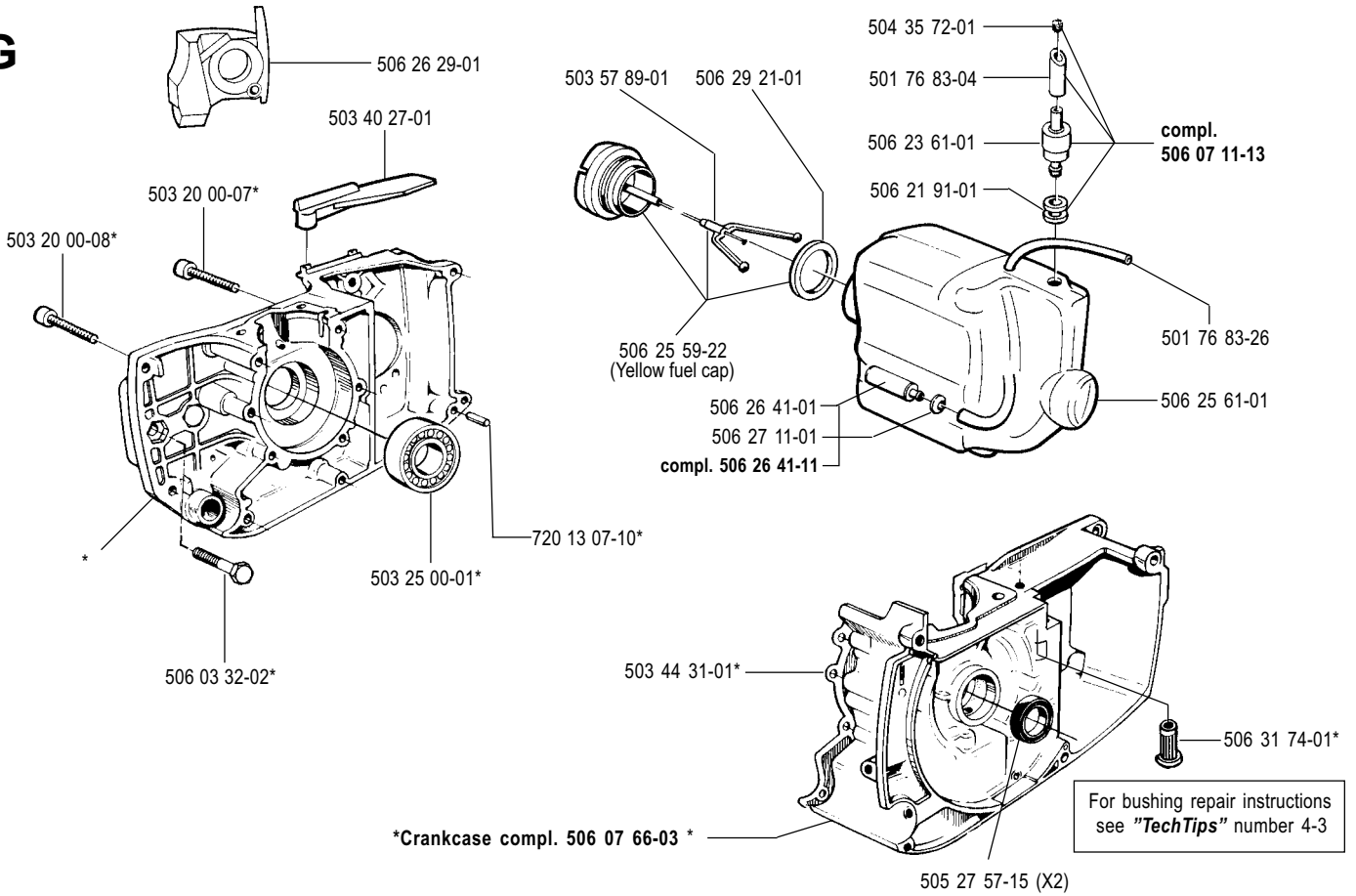

For bushing repair instructions see "TechTips" number 4-3

Early Active saws use a **black plastic** fuel tank with the filler cap by the starter assembly (left side). This tank is superseded with a translucent tank with the filler cap on the right side.

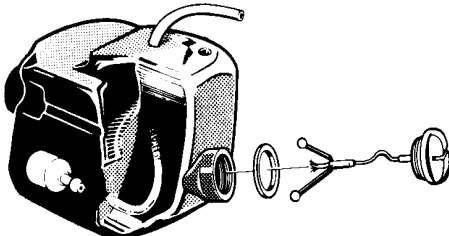

**NOTE:**  
 Replace All black gas caps with a yellow cap.  
 Contact Partner



506 23 52-02

H

506 23 64-34 USA Std  
506 27 84-21 USA EPA  
506 27 84-23 Canada EPA

506 27 84-22 (CE)

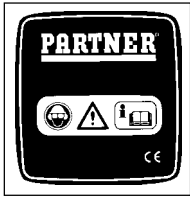

Decompression Valve  
Push before starting

506 32 21-02

\*\*506 25 82-01

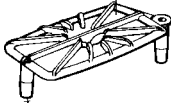

\*\*506 28 39-30

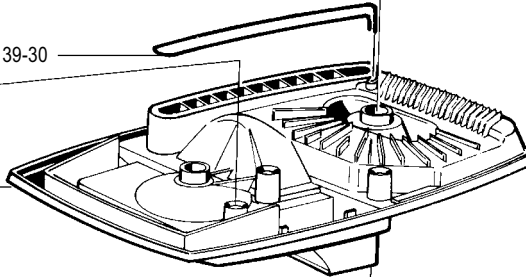

\*\*compl. 506 21 78-12

503 20 02-90



506 22 42-01

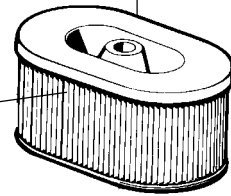

506 28 39-30

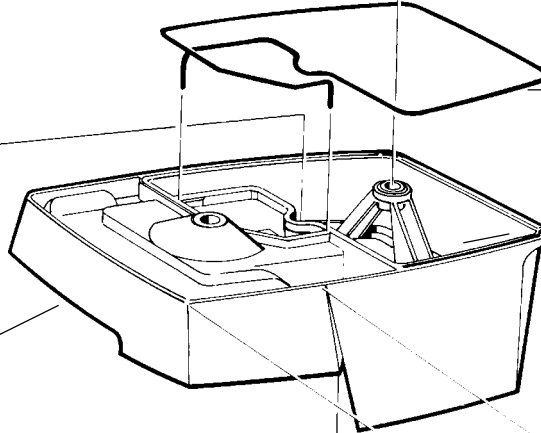

\*compl. 506 21 77-14

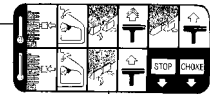

506 23 93-01\*



506 23 53-02 "Active"  
506 23 53-05 "Active II"

506 22 23-01

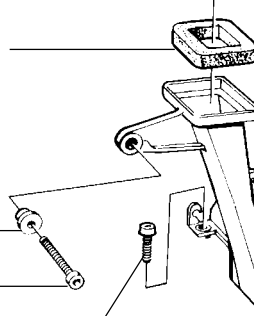

506 22 24-01

725 52 95-55

506 21 98-01

503 20 00-03

503 20 34-42



506 21 79-01

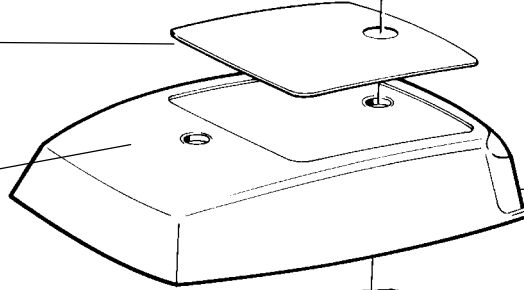

506 22 63-01

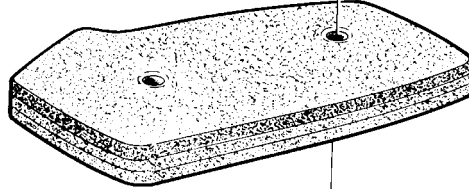

**J**

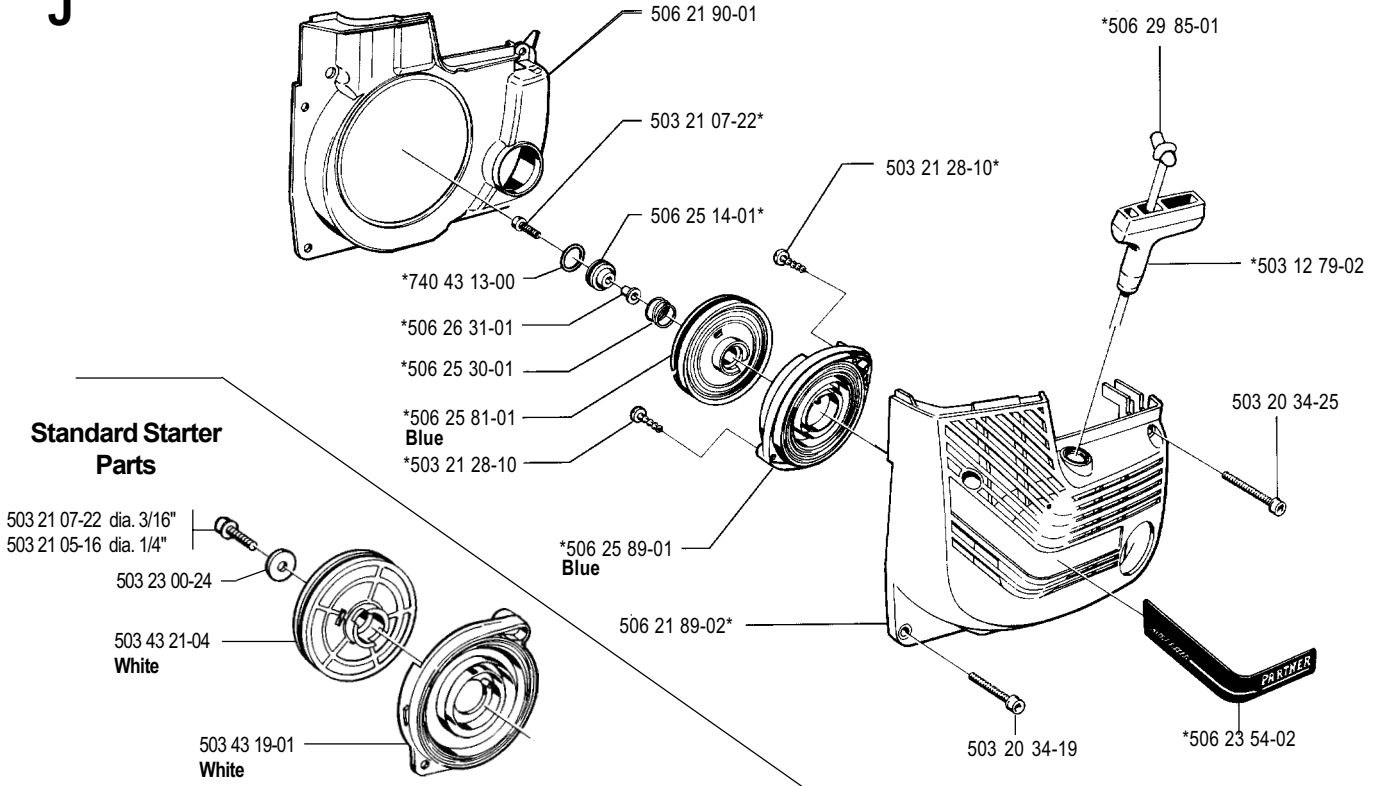

**Standard Starter Parts**

503 21 07-22 dia. 3/16"  
503 21 05-16 dia. 1/4"

**DuraStarter**

\*Starter compl. 506 25 95-01

**Note:**  
See the **Owner's Manual** for starter repairs

**K**

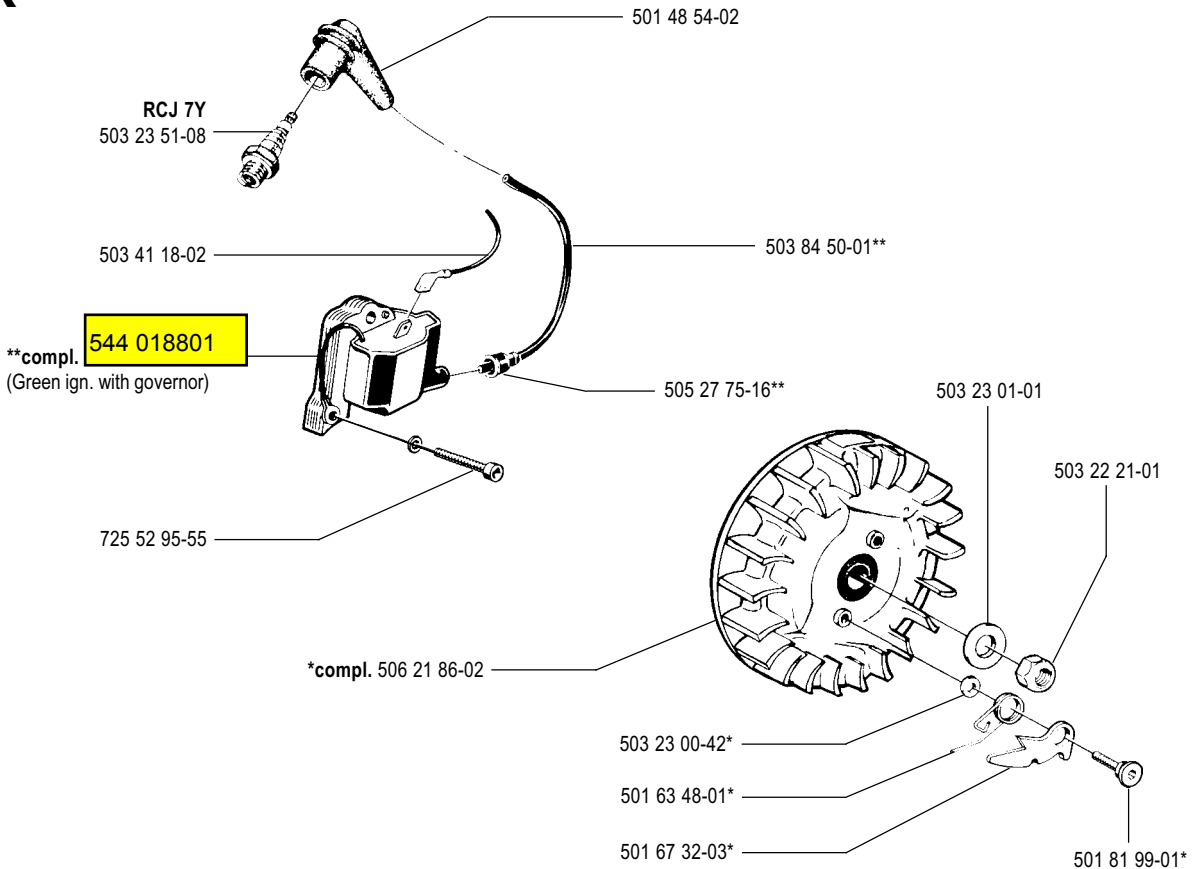

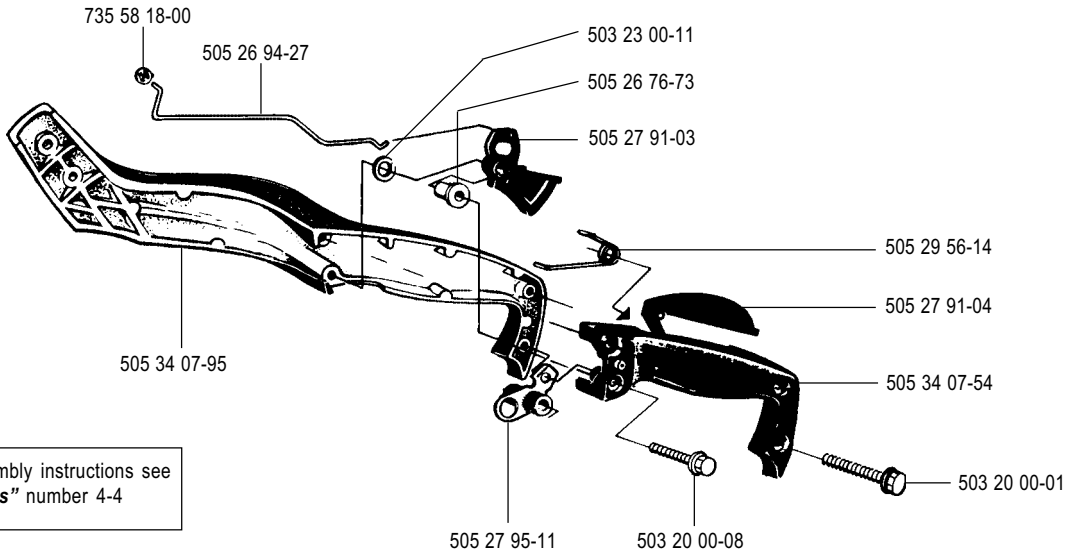
**L**

For assembly instructions see  
"TechTips" number 4-4

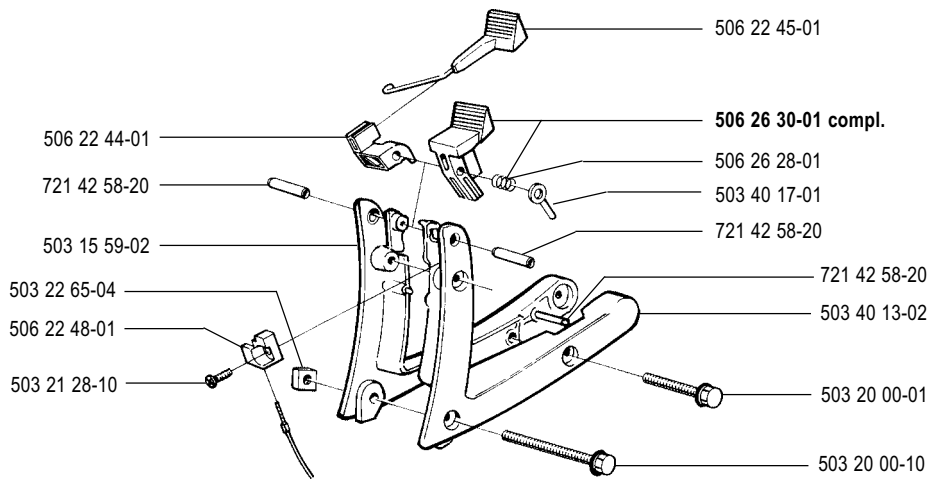
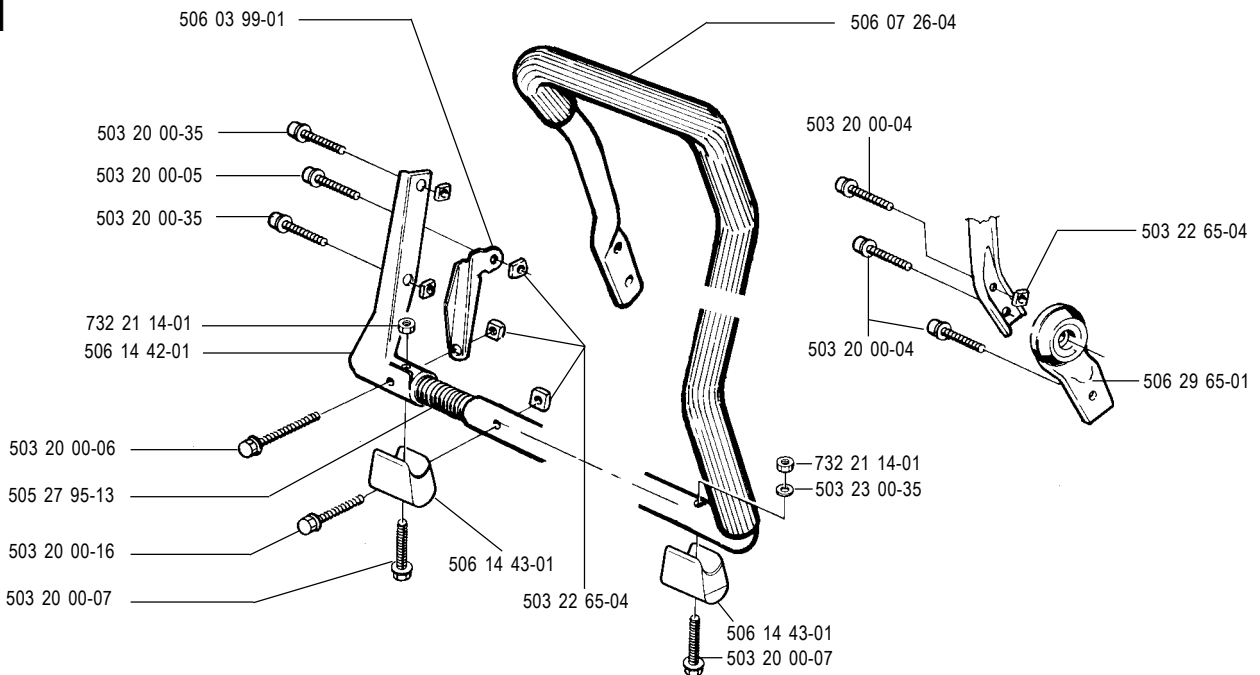
**M****N**



**Compl. 503 28 04-04 - Adjustable Jets**  
 Tillotson HS 175G "SmartCarb"

**Compl. 506 32 15-01 - Fixed Jets, "EPA"**  
 Tillotson HS 175K "SmartCarb"  
 (See below for specific parts)  
 Use only with "Green Ignition" system

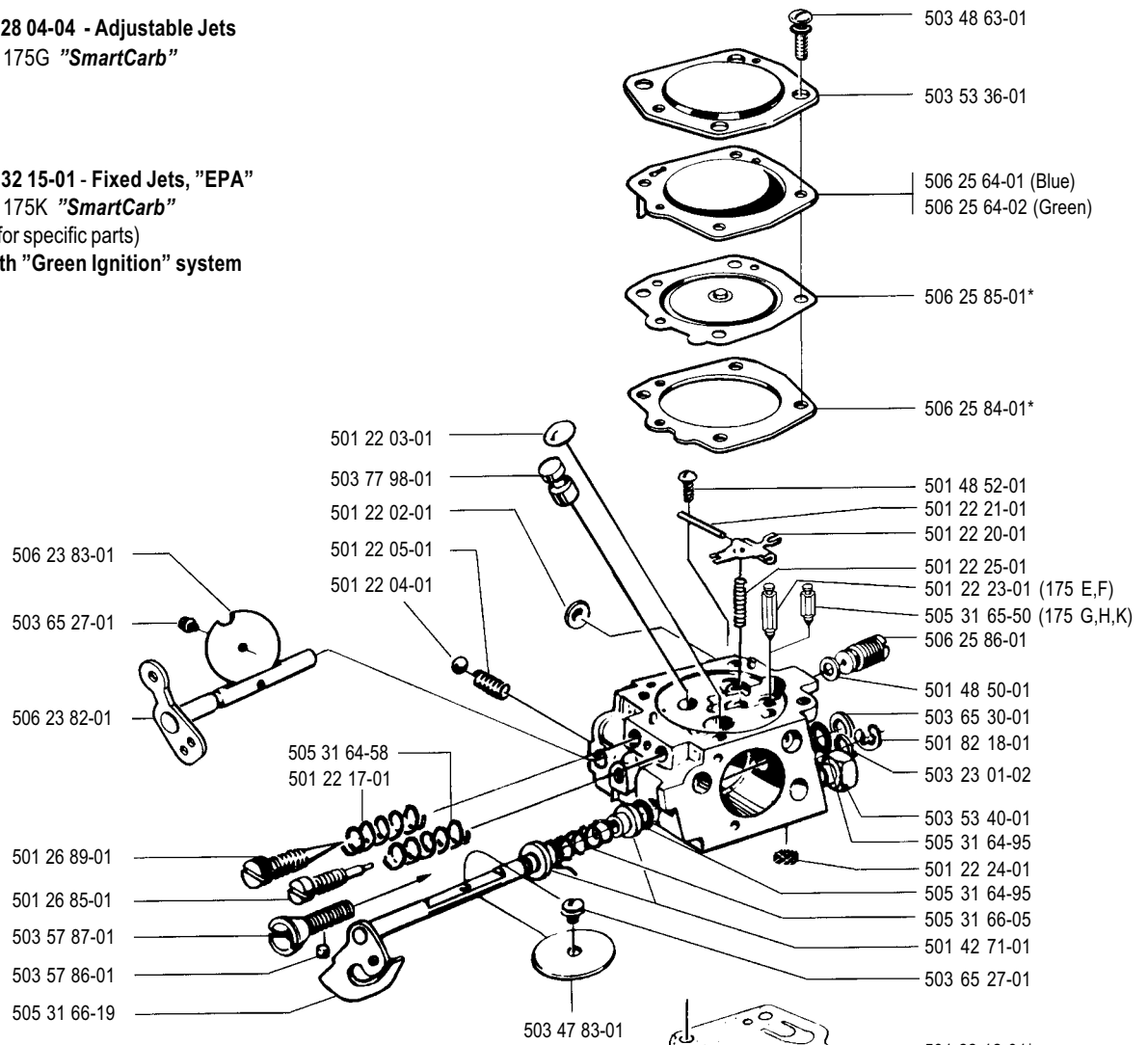

**Compl. 506 32 15-01 - Fixed Jets, "EPA"**  
 Tillotson HS 175K "SmartCarb"

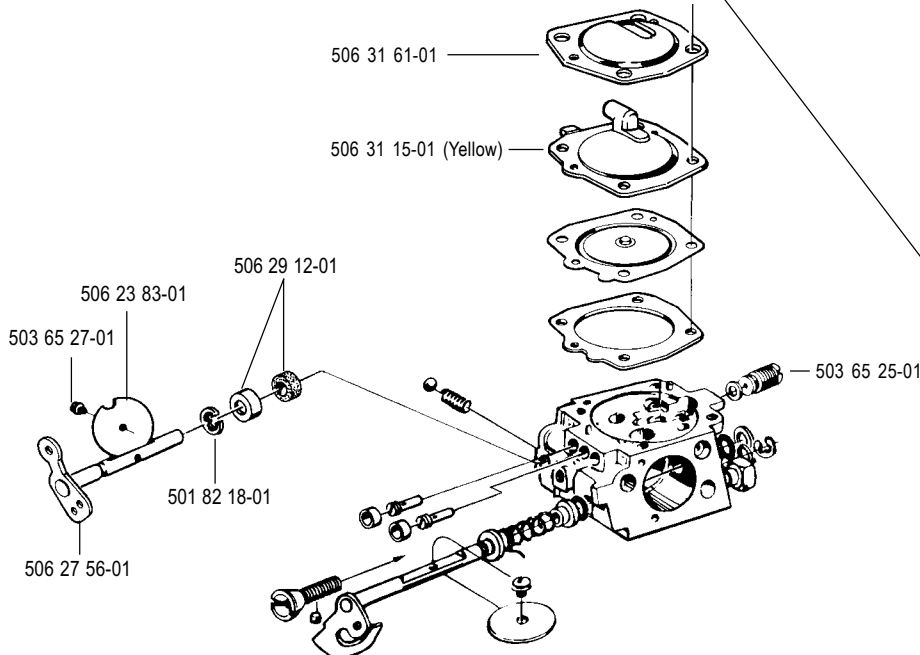

**Repair kit**  
**RK 31HS**

**Diaphragm and gasket set**  
**DG-10HS**

506 27 63-01

506 25 88-01

**Repair kits fit all Tillotson 175 series carburetors**



No.	Pos.	Description	No.	Pos.	Description	No.	Pos.	Description
501 22 03-01	O	Plug	503 55 22-01	C	Plug	506 21 89-02	J	Starter housing
501 22 04-01	O	Ball	503 57 86-01	O	Ball	506 21 90-01	J	Air conductor
501 22 05-01	O	Spring	503 57 87-01	O	Screw	506 21 91-01	G	Grommet
501 22 12-01	O	Fuel pump diaphragm	503 57 89-01	G	Holder	506 21 95-01	A	Spring
501 22 13-01	O	Gasket, pump side	503 65 25-01	O	Governor	506 21 98-01	H	Air jet
501 22 14-01	O	Cap	503 65 27-01	O	Screw	506 22 23-01	H	Sealing
501 22 15-01	O	Screw	503 65 30-01	O	Washer	506 22 24-01	H	Sealing
501 22 17-01	O	Spring	503 71 53-01	C	Valve decompr.	506 22 42-01	H	Air filter
501 22 20-01	O	Lever	503 77 98-01	O	Valve	506 22 44-01	M	Guide
501 22 21-01	O	Shaft	503 84 50-01	K	Cable	506 22 45-01	M	Choke control
501 22 23-01	O	Inlet needle, large	503 90 17-01	K	Ignition (Green)	506 22 48-01	M	Holder
501 22 24-01	O	Filter	504 35 72-01	G	Fuel filter	506 22 63-01	H	Filter
501 22 25-01	O	Spring	505 26 76-73	L	Spacer	506 22 88-02	F	Guide
501 26 85-01	O	Idle adj. screw	505 26 83-03	B	Cover	506 23 52-02	P, G	Gasket Set
501 26 89-01	O	Needle H	505 26 94-27	L	Throttle rod	506 23 53-02	H	Decal - Active
501 42 71-01	O	Bushing	505 27 57-15	B	Seal ring	506 23 53-05	H	Decal - Active II
501 48 50-01	O	Gasket	505 27 75-16	K	Insulating cap	506 23 54-02	J	Decal
501 48 52-01	O	Screw	505 27 90-60	F	Insul. flange	506 23 61-01	G	Tank vent.
501 48 54-02	K	Spark plug conn. kit	505 27 91-03	L	Throttle control	506 23 64-31	H	Decal, CE
501 50 24-01	O	Governor	505 27 91-04	L	Throttle catch	506 23 64-34	H	Warning Decal
501 60 68-01	G	Clamp	505 27 95-11	L	Absorber	506 23 64-35	H	Decal, USA
501 63 48-01	K	Spring	505 27 95-12	N	Absorber	506 23 82-01	O	Choke shaft
501 67 32-03	K	Pawl	505 27 95-13	N	Absorber	506 23 83-01	O	Choke flap
501 69 17-02	P	Comb. tool	505 29 56-14	L	Spring	506 23 93-01	H	Decal
501 76 83-04	G	Hose	505 30 23-33	E	Needle bearing	506 24 37-12	C	Cylinder cpl.
501 76 83-26	G	Hose, 245 mm	505 30 24-15	B	Needle bearing	506 25 14-01	J	Washer
501 81 99-01	K	Screw M5x14	505 30 32-37	B	Clutch	506 25 30-01	J	Spring
501 82 18-01	O	Retaining ring	505 30 32-47	B	Centrif. weight	506 25 33-01	F	Seal holder
503 12 79-02	J	Starter handle	505 30 51-20	J	Starter rope	506 25 34-01	F	Rubber seal
503 14 90-01	N	Foot	505 31 64-58	O	Pressure spring	506 25 59-22	G	Tank cap
503 15 59-02	M	Bracket right	505 31 64-95	O	X-ring	506 25 61-01	G	Tank unit
503 15 80-01	E	Crankshaft	505 31 65-50	O	Needle	506 25 64-01	O	Insert - Smart Carb
503 20 00-01	L,M	Screw M6SF 5x20	505 31 66-05	O	Spring	506 25 64-02	O	Insert
503 20 00-03	H	Screw M6SF 5x12	505 31 66-19	O	Throttle shaft	506 25 71-02	F	Smart Carb-Active Only
503 20 00-04	A,N	Screw M6SF 5x16	505 34 07-54	L	Handle, left half	506 25 71-02	F	Carburetor - Smart Carb
503 20 00-05	C,D,N	Screw M6SF 5x25	505 34 07-95	L	Handle, right	506 25 81-01	J	Starter pulley
503 20 00-06	N	Screw M5x35	505 34 11-62	C	Piston cpl 50 mm	506 25 82-01	H	Guard
503 20 00-07	G	Screw M6SF 5x40	505 35 01-50	D	Silencer	506 25 84-01	O	Gasket
503 20 00-08	G,L,N	Screw M6SF 5x30	505 39 75-88	B	Decal	506 25 85-01	O	Diaphragm
503 20 00-09	D	Screw M6SF 5x45	506 02 73-04	K	Ignition module	506 25 86-01	O	Governor
503 20 00-10	M	Screw M6SF 5x55	506 02 84-01	A	Washer	506 25 88-01	O	Diaphragm kit
503 20 00-12	B	Screw M6SF 5x70	506 02 86-01	A	Spacer	506 25 89-01	J	Return spring
503 20 00-16	N	Screw M5x28	506 02 87-01	A	Washer	506 25 95-01	J	Starter device
503 20 00-35	N	Screw	506 02 88-30	A	Bushing	506 26 28-01	M	Spring
503 20 00-45	A	Screw	506 02 91-02	A	Bearing housing	506 26 29-01	G	Protector
503 20 02-90	H	Screw	506 02 92-01	A	Guard	506 26 30-01	M	Knob
503 20 21-75	F	Screw	506 02 95-03	A	Hose - 14" Guard	506 26 31-01	J	Sleeve
503 20 30-09	A	Screw	506 02 96-01	A	Spring	506 26 41-01	G	Filter
503 20 32-42	H	Screw	506 02 98-04	A	Rod - 14" Guard	506 26 41-11	G	Filter cpl
503 20 34-19	J	Screw	506 03 00-01	A	Pulley	506 26 75-01	A	Slurry guard
503 20 34-25	J	Screw	506 03 06-02	A	Adjuster	506 26 85-01	F	Rubber seal
503 20 34-42	H	Screw	506 03 32-02	A,G	Screw	506 27 11-01	G	Weight
503 21 05-16	J	Screw - dia. 1/4"	506 03 45-01	A	Washer	506 27 56-01	O	Choke shaft
503 21 06-32	N	Screw	506 03 62-01	A	Spacer (rubber)	506 27 63-01	O	Repair kit
503 21 07-22	J	Screw	506 03 62-02	A	Spacer (rubber)	506 27 64-01	O	Diaphragm and gasket set
503 21 28-10	J,M	Screw	506 03 62-04	A	Spacer (plastic)	506 27 67-41	A	Belt
503 22 00-01	A,B	Nut M6MF M5	506 03 88-01	A	Warning label	506 27 84-21	H	Label USA EPA
503 22 21-01	K	Lock nut M8x1	506 03 95-20	A	Bushing	506 27 84-22	H	Label CE
503 22 65-04	M,N	Nut	506 03 95-22	A	Bushing	506 27 84-23	H	Label - Canada EPA
503 22 66-01	A	Nut	506 03 95-25	A	Bushing	506 27 98-01	F	Air horn with seal
503 23 00-05	A	Washer 6.5x11	506 03 99-01	N	Support	506 28 39-30	H	Sealing
503 23 00-11	L	Washer 5.3x12	506 07 07-01	A	Flange, support	506 28 40-14	A	Guard Label 14" - 1"
503 23 00-24	J	Washer - 6.4 x 18	506 07 11-13	G	Vent cpl	506 28 94-01	F,O	Carburetor, fixed jets
503 23 00-42	FK	Washer	506 07 25-01	B	Cutting arm	506 29 10-01	O	Seal kit
503 23 01-01	K	Washer 8.4x16	506 07 26-02	N	Handle	506 29 12-01	O	Seal kit
503 23 01-02	O	Washer 5.25x9	506 07 26-04	N	Front Handle	506 29 21-01	G	Gasket
503 23 01-04	A	Washer 15x21	506 07 37-01	B	Drive wheel	506 29 65-01	N	Absorber
503 23 01-11	B	Washer	506 07 66-03	G	Crankcase cpl	506 29 83-64	A	Shaft
503 23 51-08	K	Spark plug RCJ7Y	506 07 66-03	G	Crankcase Complete	506 29 85-01	J	Starter Rope
503 25 00-01	E,G	Ball bearing	506 09 64-01	F	Gasket	506 31 15-01	O	Insert - Yellow
503 25 21-01	A	Ball bearing 6202RS	506 09 82-01	B	Clutch spring	506 31 61-01	O	Cover
503 26 02-04	G	Sealing ring	506 09 90-01	C	Piston assy	506 31 74-01	G	Bushing
503 28 04-04	F,O	Carburetor	506 09 92-12	C	Cylinder cpl	506 31 88-01	F	Air horn (yellow)
503 28 90-17	C	Piston ring	506 13 95-11	A	Washer	506 32 15-01	F	Carburetor cpl
503 40 13-02	M	Bracket left	506 13 96-01	A	Screw	506 32 21-02	H	Label - Decom Valve
503 40 17-01	M	Contact spring	506 14 32-01	A	Catch	720 13 07-10	G	Pin
503 40 27-01	G	Spacer	506 14 42-01	N	Support	721 42 58-20	M	Spring pin 4x24
503 41 18-02	K	Cable	506 14 43-01	N	Support Feet	725 52 95-55	H,K	Screw MC6S 4x20
503 43 19-01	J	Spring, white	506 21 21-01	A	Washer	725 53 27-55	A	Screw MC6S 5x12
503 43 21-04	J	Pulley, white	506 21 23-01	H	Gasket	732 21 14-01	N	Locknut
503 44 31-01	G	Gasket	506 21 27-02	C	Gasket	735 31 09-20	A	E-ring 5
503 47 83-01	O	Shutter	506 21 28-01	C	Deflector	735 58 18-00	L	Lock washer 2.4
503 48 63-01	O	Cover screw	506 21 41-01	F	Intake (black)	735 88 06-00	E	Woodruff key
503 49 08-01	F	Gasket	506 21 77-14	H	Cyl.Cover 650/700	737 43 12-00	C	Retaining ring
503 49 09-01	F	Gasket	506 21 78-11	H	Filter holder	738 22 02-29	A	Ball bearing 6202-2RS1
503 49 10-01	C	Gasket	506 21 78-12	H	Filter Bottom	740 42 01-00	F	O-ring
503 53 36-01	O	Cover	506 21 79-01	H	Filter cover	740 43 13-00	J	O-ring
503 53 40-01	O	Nipple	506 21 86-02	K	Flywheel compl.			



### Thread Repair Bushing Part # 506 31 74-01

Partner offers a simple repair to a stripped-out thread or threaded bushing for the cylinder cover on the **K650/K700 ACTIVE** saws. The threaded insert can be installed without removing the cylinder.

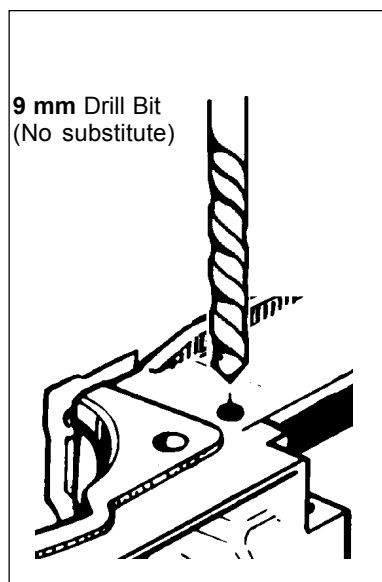

#### Step 1

Drill the existing hole with a **9.0 mm**, drill bit. Drill the hole clear through into the cavity underneath.

**Note: It is not necessary to remove the cylinder and carburetor.**

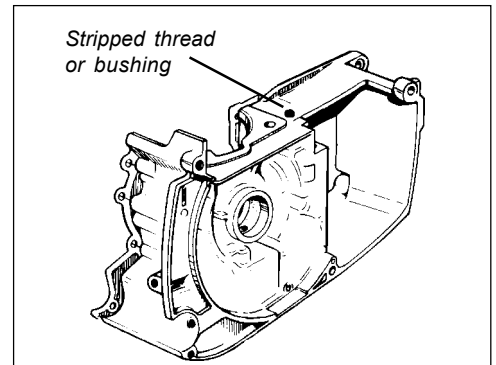

#### Step 2

Remove the flywheel.

Insert the repair bushing into the hole through the opening in the crankcase under the flywheel.

Note the location of the flat spot on the bushing

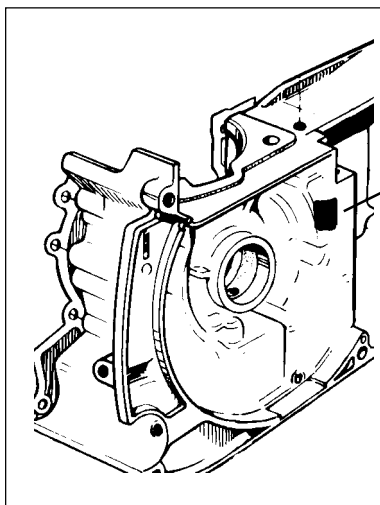

**Part # 506 31 74-01**

#### Step 3

Pull the bushing into place by using a M5 screw such as the rear handle screw.

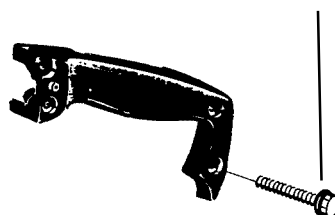



### Assembly of Rear Handle K650/K700 and K1200

When the handle is apart, follow these steps for re-assembly.

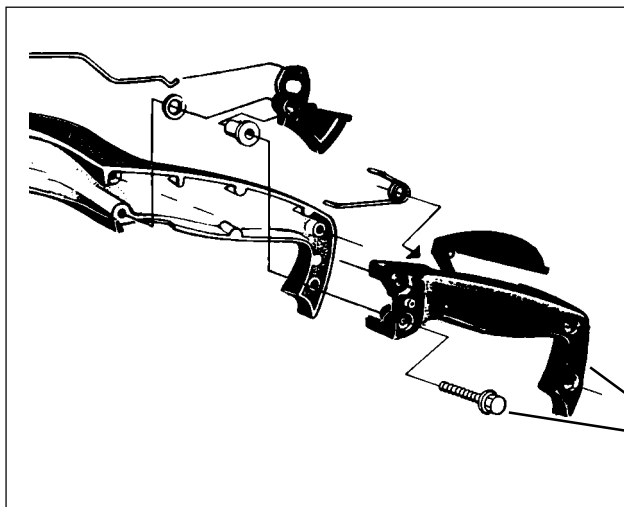

1. Insert the longer handle screw into this hole in the left handle half . This screw acts as a pivot for the trigger.

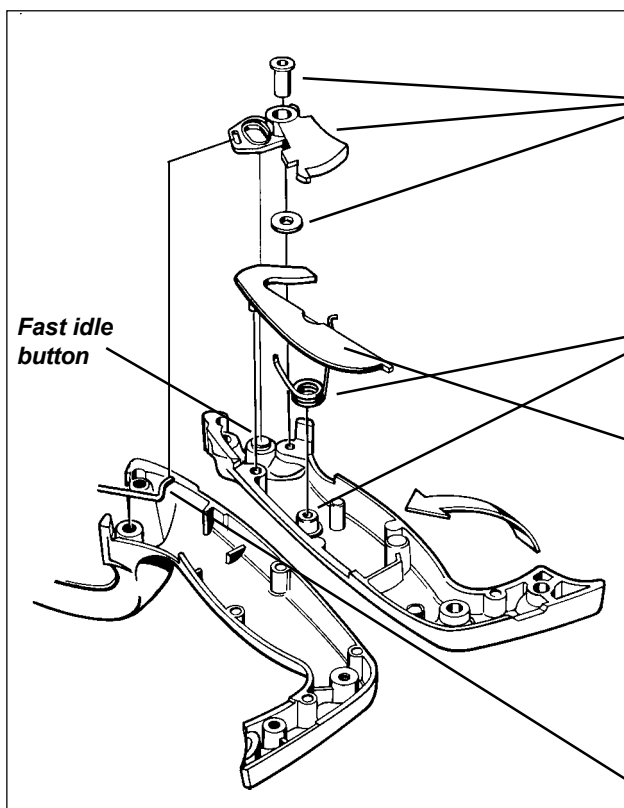

2. Install the **washer**, **trigger** and **sleeve** onto the screw.
3. Install the **spring** on the post identified in the drawing and insert the hook on the spring into matching hole on the trigger.
4. Install the **throttle lockout**.
5. Set the **fast idle button** by pressing on the throttle lockout and the trigger simultaneously. The fast idle button effectively holds the parts in place.
6. Install the handle assembly onto throttle linkage.