

# PARTS LIST

**CHAIN SAW**

**G621AVS**

**NOTE :**

1. Use ZENOAH genuine parts specified in the parts list for repair and/or replacement.
2. ZENOAH does not warrant the machines, those which have been damaged by the use of any parts other than those specified by the company.
3. When placing orders of parts for repair and/or replacement, check if the model name and the serial number are suitable to those specified in the parts list, then use parts number described in the parts list.
4. The contents described in the parts list may change due to improvement.
5. The parts for the machine shall be supplied within ten (10) years after the machine is discontinued.  
[It is possible that some specific parts may be subject to change of their delivery term and list price within the limit of ten (10) years after the machine is discontinued. And it is also possible that some parts may be available even after the limit of ten (10) years.]

Fig.1 POWER UNIT

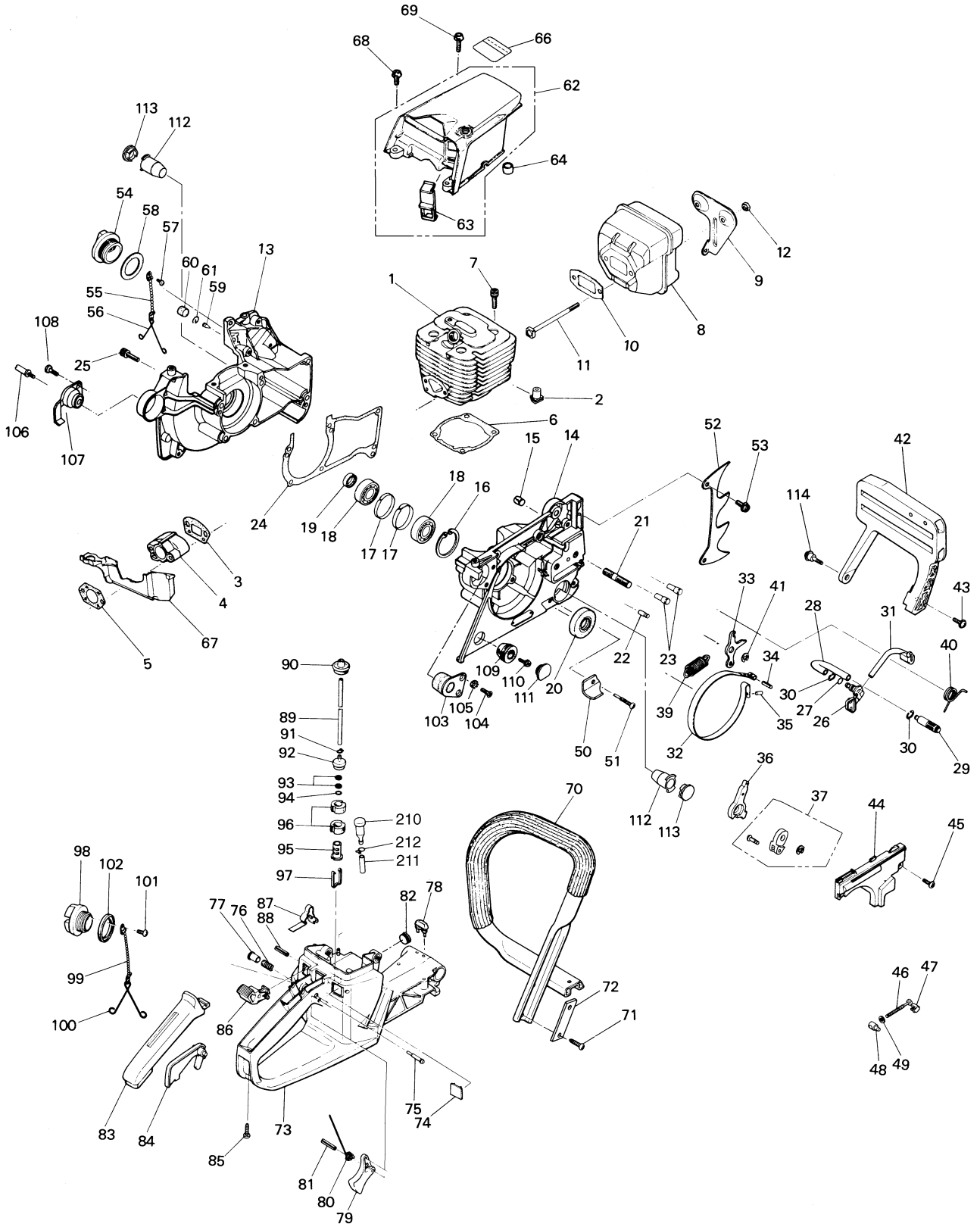

Fig.1 POWER UNIT

Key#	PART NUMBER	DESCRIPTION	Q'TY /UNIT	NOTE	Key#	PART NUMBER	DESCRIPTION	Q'TY /UNIT	NOTE
1	848C9712A0	CYLINDER	1		62	2626-31104	COVER COMP., cylinder	1	Incl. 62 thru 63
2	3356-12141	GROMMET	1		63	3356-31152	• GROMMET	1	
3	848C9014B3	GASKET, insulator	1		64	3356-31120	CAP, cylinder cover	1	
4	2618-14120	INSULATOR	1						
5	848C9014C2	GASKET, carburetor	1		66	2627-31171	LABEL	1	
6	2616-14211	GASKET, cylinder base	1		67	3356-31212	SEAL, cylinder cover	1	
7	3310-12281	BOLT	4		68	0263-90514	SCREW	2	
8	2610-15111	MUFFLER	1		69	0263-90520	SCREW	1	
9	3356-15123	STAY	1		70	2620-32100	FRONT HANDLE COMP.	1	
10	3356-15210	GASKET, muffler	1	K1	71	8488251901	SCREW	4	
11	3356-15220	BOLT	2		72	2851-32180	PLATE	2	
12	2850-15230	NUT	2						
	848C902104	CRANKCASE ASSY	1	Incl. 13 thru 24	73	2622-33005	REAR HANDLE ASSY	1	Incl. 73 thru 82
13	☆	CRANKCASE MAG	1	☆848C902104	74	2622-33105	REAR HANDLE COMP.	1	
14	☆	CRANKCASE PTO	1	☆848C902104	75	3350-33220	PLATE	1	
15	3356-21130	PIN	3		76	3330-33250	STOPPER	1	
16	04065-03515	SNAP RING	1		77	3310-33262	SPRING	1	
17	2616-21250	RING	2		78	3310-33271	KNOB	1	
18	T4012-21240	BEARING	2		79	2810-33280	DAMPER (A)	1	
19	3350-21210	OIL SEAL, MAG	1		80	848C1033C3	LEVER, throttle	1	
20	T1108-21220	OIL SEAL, PTO	1		81	3356-33321	SPRING, throttle	1	
21	2616-21230	STUD	2		82	04025-00524	SPRING PIN	1	
22	3350-21250	SPRING PIN	1		83	2616-33412	DAMPER (B)	1	
23	3356-21270	PIN, brake arm	2		84	3356-34111	COVER, grip	1	
24	848C9021D2	GASKET, crankcase	1	K1	85	848C3033E3	ARM	1	
25	3310-12281	BOLT	6		86	3356-32210	SCREW	1	
	3356-23100	OIL PIPE COMP.	1	Incl. 26 thru 30	87	3350-34210	LEVER, switch	1	
26	3356-23110	PIPE, oil	1		88	3356-34221	SPRING, switch	1	
27	07000-11008	O-RING	1			2616-34230	SPRING PIN	1	
28	3310-57312	PIPE	1			3356-34301	FUEL PIPE ASSY	1	Incl. 89 thru 97
29	3310-57412	WEIGHT	1		89	3356-34310	PIPE	1	
30	3310-57511	CLIP	2		90	3356-34320	GROMMET	1	
31	3356-23211	PIPE, oil	1		91	1260-85460	CLIP	1	
	3356-24101	BRAKE BAND COMP.	1	Incl. 32 thru 34		3302-85400	FILTER ASSY	1	Incl. 94 thru 97
32	3356-24111	BAND, brake	1		92	☆	BODY	1	☆3302-85400
33	3356-24120	ARM, brake	1		93	☆	SCREEN	2	
34	04025-00408	SPRING PIN	1		94	☆	RING	1	☆3302-85400
35	3356-24140	ROLLER	1		95	☆	SLEEVE	1	☆3302-85400
36	2622-24210	LEVER	1		96	☆	FILTER	2	
37	848C925431	STOPPER COMP.	1		97	☆	CLIP	1	☆3302-85400
	2622-24600	SPRING, brake	1			3350-34400	CAP ASSY, fuel tank	1	Incl. 98 thru 102
39	3356-24240	SPRING	1		98	☆	CAP, fuel tank	1	☆3350-34400
40	0308-00060	SNAP RING	2		99	☆	CHAIN, cap	1	☆3350-34400
41	848C9254A1	GUARD	1		100	☆	STOPPER	1	☆3350-34400
42	2670-14320	SCREW	1		101	☆	SCREW	1	☆3350-34400
43	3356-24412	COVER, brake	1		102	3350-34450	GASKET	1	
44	0263-60514	SCREW	2		103	2616-35151	DAMPER, rear right	1	
45	3350-25111	SCREW, chain adjust	1		104	0262-10514	SCREW	2	
46	3350-25121	STOPPER, adjust screw	1		105	3320-14140	WASHER	2	
47	3320-21191	NUT (A)	1		106	2616-35170	BOLT	2	
48	01641-20508	WASHER	1		107	2616-35132	DAMPER, rear left	1	
49	2616-25211	CATCHER, chain	1		108	2616-25320	SCREW	2	
50	2616-25230	SCREW	1		109	2616-35141	DAMPER, rear right bottom	1	
51	2623-25310	SPIKE	1		110	1490-32120	SCREW	1	
52	2616-25320	SCREW	2		111	2856-35180	CAP	1	
	3356-26100	CAP ASSY, oil tank	1	Incl. 54 thru 58	112	2616-35112	DAMPER, front	2	
54	☆	CAP, oil tank	1	☆3356-26100	113	3356-35121	CAP	2	
55	☆	CHAIN, cap	1	☆3356-26100	114	848C9075Z1	SCREW	1	
56	☆	STOPPER	1	☆3356-26100		3350-34501	BREATHER ASSY	1	Incl. 210 thru 212
57	☆	SCREW	1	☆3356-26100	210	3317-86100	BREATHER	1	
58	3317-57220	GASKET	1		211	3350-34540	PIPE	1	
59	3330-23121	VALVE	1		212	1260-85460	CLIP	1	
60	3350-26220	SEAL, breather	1						
61	3350-26230	CLIP	1						

Fig.2 POWER UNIT

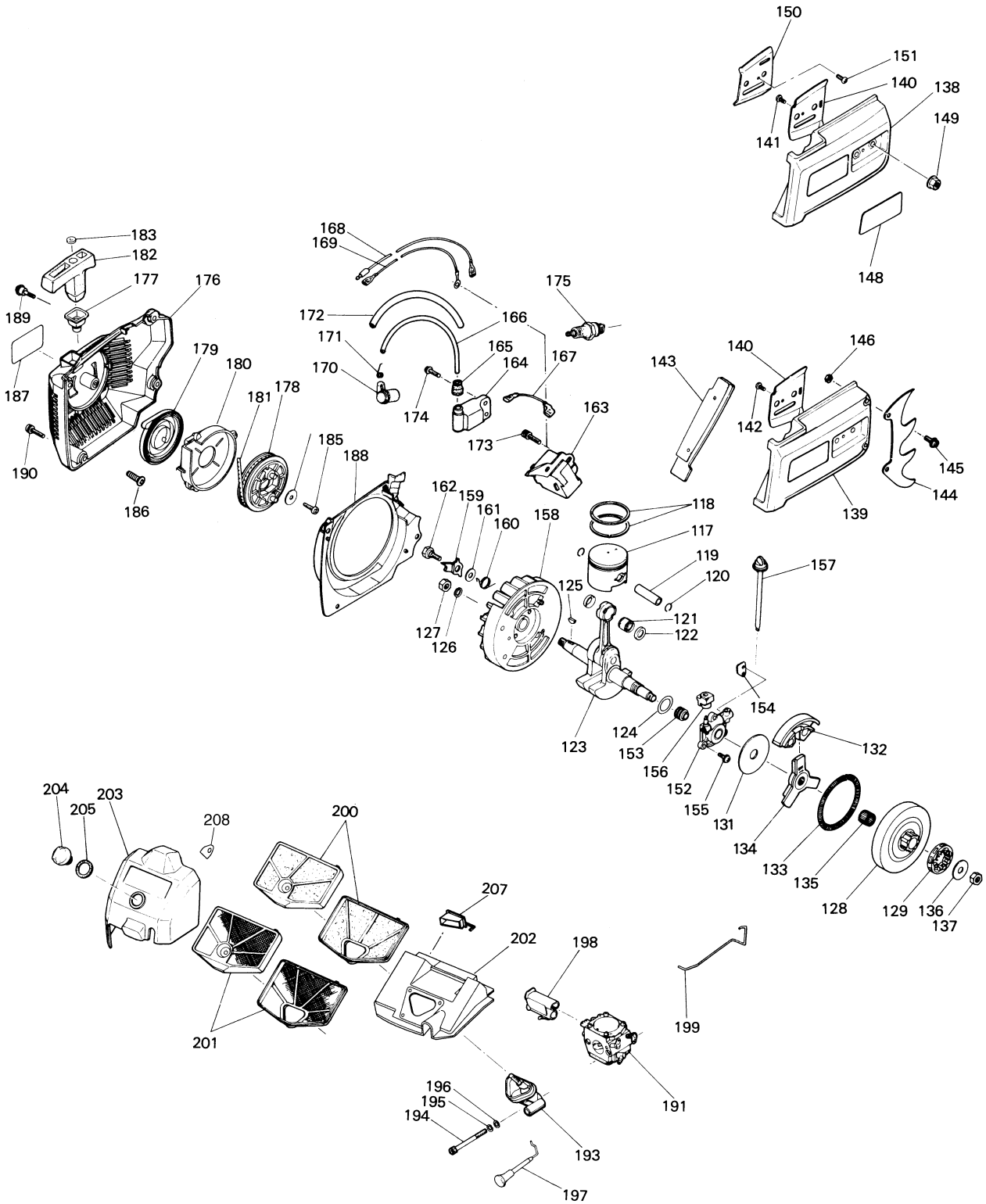
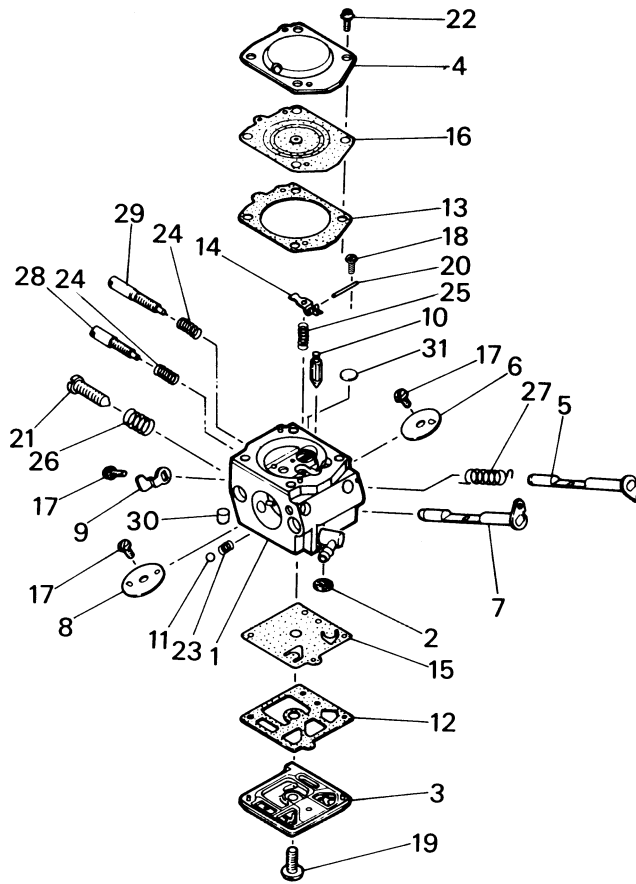

Fig.2 POWER UNIT

Key#	PART NUMBER	DESCRIPTION	Q'TY /UNIT	NOTE	Key#	PART NUMBER	DESCRIPTION	Q'TY /UNIT	NOTE
117	2618-41112	PISTON	1		167	2616-71410	CORD, primary	1	
118	2618-41210	RING, piston	2		168	2616-71420	CORD, switch	1	
119	3366-41310	PIN, piston	1		169	2616-71430	CORD, earth	1	
120	3350-41320	SNAP RING	2		170	2850-72110	CAP, spark plug	1	
121	1400-41410	NEEDLE BEARING	1		171	1400-72121	SPRING, plug cap	1	
122	2616-41510	THRUST WASHER	2		172	2850-71320	TUBE, high tension	1	
123	2616-42007	CRANKSHAFT COMP.	1		173	3350-15250	BOLT	2	
124	1300-42410	SHIM	0~2		174	0263-30416	SCREW	2	
125	1000-43240	KEY	1		175	3699-90032-10	SPARK PLUG	1	Champion RCJ-7Y
126	0290-21025	WASHER	1			2618-75004	STARTER ASSY	1	Incl. 176 thru 186
127	1300-43231	NUT	1			2618-75103	STARTER CASE COMP.	1	Incl. 176 & 177
128	3350-51110	DRUM, clutch	1		176		CASE, STARTER		
129	3360-51120	RIM, sprocket	1	3/8Px7T	177	2616-75120	GUIDE, rope	1	
	2616-51202	CLUTCH ASSY	1	Incl. 131 thru 134	178	3350-75213	REEL	1	
131	2616-51210	PLATE, clutch	1			3356-75302	SPIRAL SPRING COMP.	1	Incl. 179 & 180
132		SHOE, clutch	1		179		SPRING, spiral	1	
133	3350-51231	SPRING, clutch	1		180		HOLDER, spring	1	
134		BOSS, clutch	1		181	3356-75410	ROPE	1	
135	3320-41410	NEEDLE BEARING	1		182	3350-75420	KNOB, starter	1	
136	3350-51320	WASHER	1		183	3310-75431	WASHER	1	
137	3310-43220	NUT	1		184	3320-75350	WASHER	1	
	3356-53003	CHAIN COVER ASSY	1	Incl. 138 thru 141	185	1490-32120	SCREW	1	
	2618-53002	CHAIN COVER ASSY	1	OP Incl. 139 thru 143	186	2630-82550	SCREW	2	
138	☆	CHAIN COVER	1	☆3356-53003	187	2623-75131	LABEL	1	
139	☆	CHAIN COVER	1	OP ☆2618-53002	188	3366-75612	COVER, fan	1	
140	3356-53220	PLATE, outer	1		189	848C9075Z1	SCREW	1	
141	0277-10410	SCREW	1		190	2616-75720	SCREW	3	
142	0261-00410	SCREW	1	OP K6	191	848C928102	CARBURETOR ASSY	1	Ref. Fig.3
143	2616-53300	PROTECTOR COMP.	1	OP K6	193	3356-82114	MANIFOLD	1	
144	2618-53510	SPIKE	1	OP K6	194	8488158500	BOLT	2	
145	2670-14320	SCREW	2	OP K6	195	01601-20513	WASHER	2	
146	3310-53331	NUT	2	OP K6	196	01641-20508	WASHER	2	
148	2623-53121	LABEL	1		197	2616-82310	ROD, choke	1	
149	3350-53410	NUT, chain cover	2		198	3356-82321	GUIDE, adjuster	1	
150	3356-53210	PLATE, inner	1		199	2616-82410	ROD, throttle	1	
151	0261-00410	SCREW	1		200	848C908315	AIR CLEANER COMP.	1	Felt type, Incl. 208
	848C906703	OIL PUMP ASSY	1	Incl.152 & 153	201	848C918311	AIR CLEANER COMP.	1	OP Nylon net type, Incl. 208
152	848C906713	BODY	1		202	2627-83201	SILENCER COMP.	1	
153	3356-55120	WORM	1			2622-83302	CLEANER COVER COMP.	1	Incl. 203 thru 205
154	3356-55310	GASKET, oil pump	1		203	☆	COVER, air cleaner	1	☆2622-83302
155	0263-90520	SCREW	3		204	3356-83322	KNOB	1	
156	3356-55450	GROMMET, oil pump	1		205	3388-83340	GASKET, knob	1	
157	3356-55511	SHAFT, oil adjust	1		207	2610-83220	CAP, silencer	1	
	2618-71102	ROTOR COMP.	1	Incl. 159 thru 162	208	848C9083C0	PLATE	1	
158	2616-71112	ROTOR	1						
159	3366-71120	RATCHET	2						
160	3350-71131	SPRING	2						
161	3388-71150	WASHER	2						
162	3310-71142	BOLT	2						
163	848C9071B1	SOURCE COIL	1						
	2616-71301	IGNITION COIL COMP.	1	Incl. 164 thru 166					
164	☆	COIL, ignition	1	☆2616-71301					
165	2616-71320	CAP	1						
166	2616-71331	CORD, high tension	1						

**Fig.3 CARBURETOR COMPONENTS**



Key#	PART NUMBER	DESCRIPTION	Q'TY /UNIT	NOTE	Key#	PART NUMBER	DESCRIPTION	Q'TY /UNIT	NOTE
	848C928102	CARBURETOR ASSY	1		22	3310-81351	SCREW ASSY	4	
1		BODY ASSY	1		23	3350-81350	SPRING, friction	1	
2	3306-81380	SCREEN, inlet	1		24	1491-81161	SPRING, needle adjust	2	
3	3350-81130	COVER, pump	1		25	3350-81370	SPRING, metering lever	1	
4	3350-81140	COVER, diaphragm	1		26	3350-81380	SPRING, idle speed	1	
5	3366-81151	SHAFT ASSY, throttle	1		27	3350-81391	SPRING, throttle return	1	
6	3366-81340	VALVE, throttle	1		28	2618-81410	NEEDLE, high speed	1	
7	3356-81171	SHAFT ASSY, choke	1		29	2610-81420	NEEDLE, idle	1	
8	2616-81180	VALVE, choke	1		30	3356-81430	PLUG, friction	1	
9	3350-81190	STOP, throttle	1		31	1480-81420	PLUG, welch	1	
10	3356-81310	VALVE, inlet	1		K2	3350-06020	GASKET KIT	1	OP
11	3350-81220	BALL, friction	1		K3	3350-06030	DIAPHRAGM KIT	1	OP
12	3350-81230	GASKET, pump	1	K2					
13	3350-81240	GASKET, diaphragm	1	K2					
14	3350-81250	LEVER, metering	1						
15	2618-81260	DIAPHRAGM, pump	1	K3					
16	3350-81270	DIAPHRAGM ASSY	1	K3					
17	2880-81470	SCREW, valve	3						
18	3310-81240	SCREW, metering lever	1						
19	1491-81130	SCREW, pump cover	1						
20	3310-81250	PIN, metering lever	1						
21	2670-81430	SCREW, idle speed	1						

Fig.4 ACCESSORIES

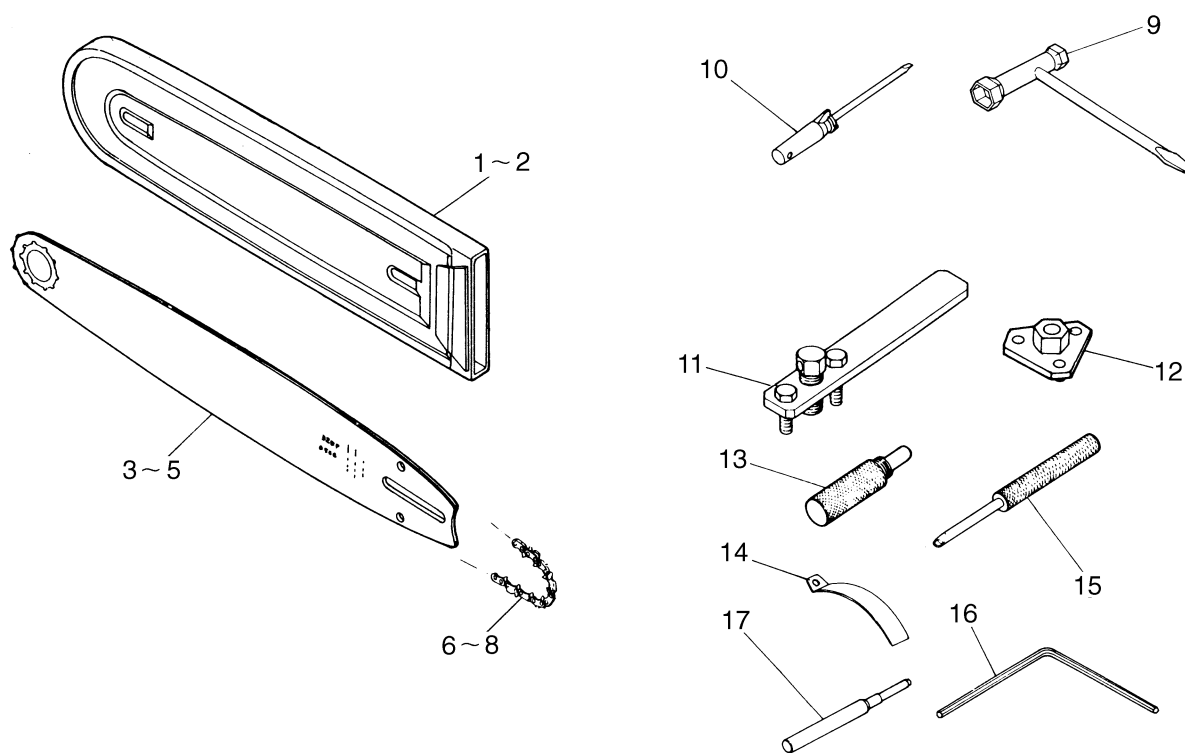

Key#	PART NUMBER	DESCRIPTION	Q'TY /UNIT	NOTE
1	3356-97110	PROTECTOR, guide bar	1	OP for 16"~18" bar
2	3665-97110	PROTECTOR, guide bar	1	OP for 20"~24" bar
3	3670-52112	BAR 16", sprocket nose	1	OP 3/8
4	3673-52113	BAR 18", sprocket nose	1	OP 3/8
5	3674-52113	BAR 20", sprocket nose	1	OP 3/8
6	848CC3LG60	CHAIN, for 16" bar	1	OP 73LGX-60E
7	848CC3LG66	CHAIN, for 18" bar	1	OP 73LGX-66E
8	848CC3LG72	CHAIN, for 20" bar	1	OP 73LGX-72E
9	3320-91140	PLUG WRENCH	1	
10	2670-91150	SCREWDRIVER	1	
	2616-96000	SPECIAL TOOL KIT	1	OP Incl. 11 thru 17
11	2890-96100	PULLER ASSY. rotor	1	OP
12	2616-96210	WRENCH, clutch	1	OP
13	3350-96220	STOPPER, piston	1	OP
14	3350-96240	GAUGE, air gap	1	OP
15	3350-96510	GUIDE, brake spring	1	OP
16	3330-97210	WRENCH	1	OP
17	3356-96230	GUIDE, piston pin	1	OP