

CHAIN SAW PARTS LIST

XL-113

XL-114

XL-122*

HOMELITE®

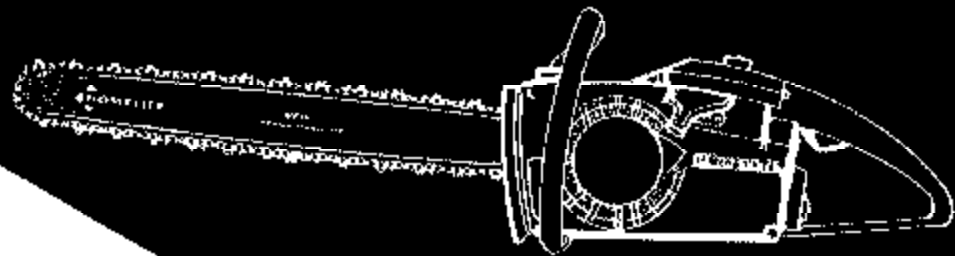

***INTERNATIONAL SALES ONLY**

Part No. 24360 Rev. 1

HOMELITE XL CHAIN SAWS

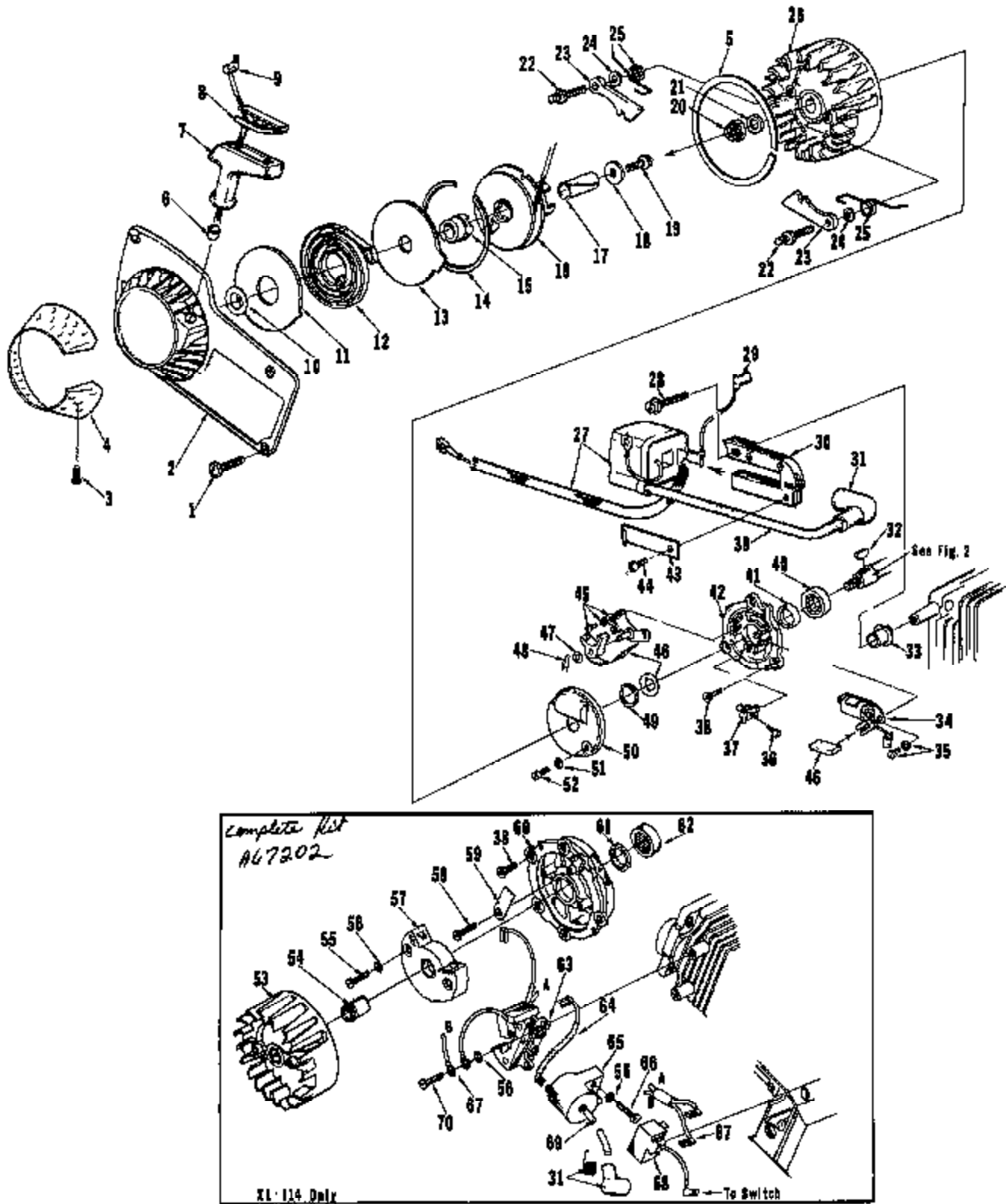

FIGURE 1

HOMELITE XL CHAIN SAWS

See Memo 972CS

No.	Description	Part No.	XL-113	XL-114	XL-122	Qty.
1	SCREW-hex, 8-32 x 1/2	80883	x	x	x	4
2	HOUSING-fan	A-67182-A	x	x	x	1
3	Includes: STUD-drive	67181	x	x	x	4
4	SCREEN-fan housing	65491	x	x	x	1
5	RING-air flow	67222	x	x	x	1
6	BUSHING-starter rope	67177	x	x	x	1
7	GRIP-starter rope	64186	x	x	x	1
8	INSERT-rope retaining	64164	x	x	x	1
9	ROPE-starter	63660	x	x	x	1
10	WASHER	67185	x	x	x	1
11	SHIELD-spring (inner)	63713	x	x	x	1
12	SPRING-rewind	63870	x	x	x	1
13	SHIELD-spring (outer)	63714	x	x	x	1
14	RING-shield retaining	63676	x	x	x	1
15	LOCK-spring	64943	x	x	x	1
16	PULLEY & CUP ASSY.	A-83952-A	x	x	x	1
17	BUSHING-starter post	64974	x	x	x	1
18	WASHER-retaining	63660	x	x	x	1
19	SCREW-hex, 10-32 x 1/2	80648	x	x	x	1
20	NUT-lock, 5/16-24	81112	x	x	x	1
21	WASHER-flat, 6/16	64086-1	x	x	x	1
22	STUD-shoulder	63677	x	x	x	2
23	PAWL-starter	64442	x	x	x	2
24	WASHER-flat	63851	x	x	x	2
25	SPRING-starter pawl	63758-2	x	x	x	2
26	ROTOR-magneto	63887	x	x	x	1
27	COIL-ignition	64021	x	x	x	1
28	SCREW-coil bore	64021	x	x	x	2
29	LEAD-ground to switch	A-63939	x	x	x	1
30	CORE-coil	64422	x	x	x	1
31	TERMINAL-spark plug	A-83055	x	x	x	1
32	KEY-woodruff	76078	x	x	x	1
33	RETAINER-lead	64301	x	x	x	1
34	CONDENSER & CLAMP	64086	x	x	x	1
35	SCREW-condenser clamp	64411	x	x	x	2
36	SCREW-terminal	64090	x	x	x	2
37	BLOCK-terminal	64088	x	x	x	1
38	SCREW-back plate retainer	63821	x	x	x	5
39	LEAD-high tension	63660	x	x	x	1
40	BEARING-roller	67385	x	x	x	1
41	SEAL	63688-A	x	x	x	1
42	PLATE-back	63624-1A	x	x	x	1
43	CLIP-coil retaining	64423	x	x	x	1
44	SCREW-coil retaining clip	63873	x	x	x	1
45	SCREW-breaker clamp	76421	x	x	x	2
46	POINT-act w/felt	A-64087	x	x	x	1
47	Includes: WASHER-post	28028	x	x	x	1
48	CLIP-post	28008	x	x	x	1
49	RETAINER-felt	64089	x	x	x	1
50	COVER-breaker box	A-83928	x	x	x	1
51	WASHER-flat, #8	64018	x	x	x	2
52	SCREW-cover	64086	x	x	x	2
53	ROTOR-magneto	67284	x	x	x	1
54	CAP-chest	64423	x	x	x	1
55	SCREW-pan, 8-32 x 3/8	82177	x	x	x	2
56	WASHER-lock, #8	63022	x	x	x	6
57	MODULE-ignition	67283	x	x	x	1
58	SCREW-pan, 8-32 x 5/16	80603	x	x	x	1
59	CLAMP-condenser lead	67285	x	x	x	1
60	PLATE-back	A-67287	x	x	x	1
61	Includes: SEAL	63688-A	x	x	x	1
62	BEARING-roller	67385	x	x	x	1
63	CORE & COIL	67277	x	x	x	1
64	LEAD-transformer	67483	x	x	x	1
65	TRANSFORMER	67275	x	x	x	1
66	SCREW-ful, 6-32 x 7/8	80183	x	x	x	2
67	LEAD-condenser	67280	x	x	x	1
68	CONDENSER	67281	x	x	x	1
69	LEAD-high tension	67484	x	x	x	1
70	SCREW-pan, 8-32 x 3/8	82177	x	x	x	2

ALWAYS FURNISH MODEL AND SERIAL NUMBER WHEN ORDERING PARTS.

HOMELITE XL CHAIN SAWS

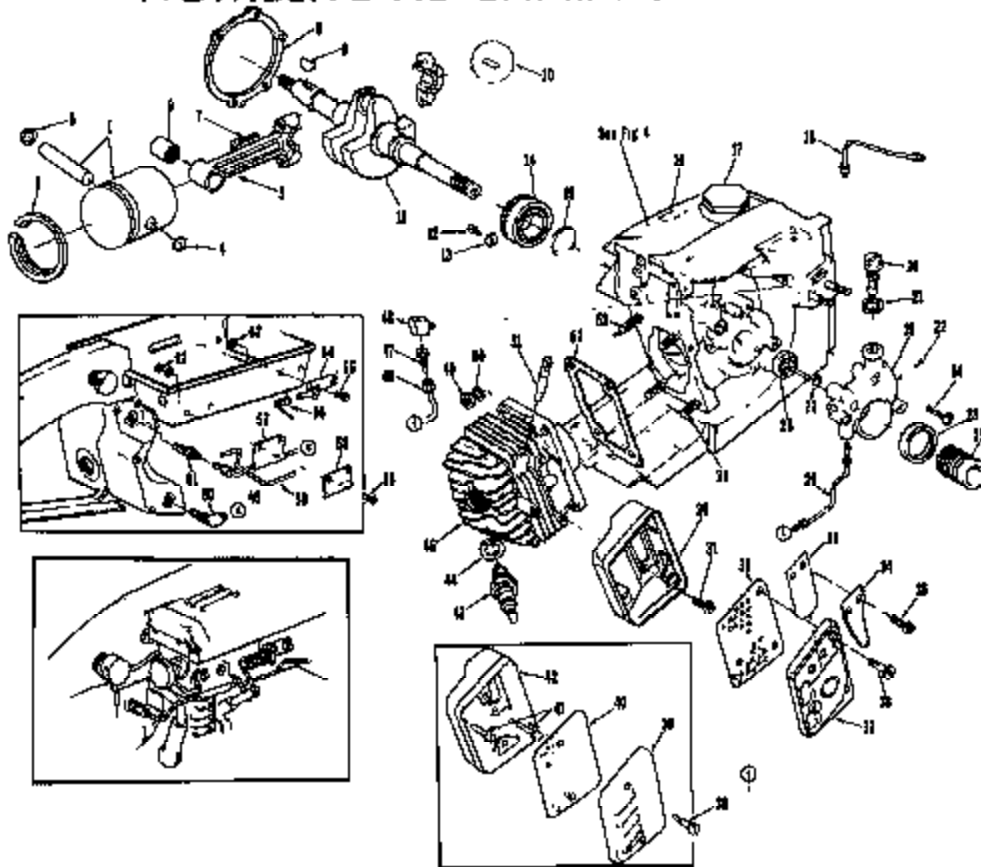

FIGURE 2

No.	Description	Part No.	XL-113	XL-114	XL-122	Qty.	No.	Description	Part No.	XL-113	XL-114	XL-122	Qty.
1	PISTON & PIN	A-67686	x	x	x	1	*14	STOP-valve	87418-1	x	x	x	1
2	Includes PISTON RING-"U" shaped	87340	x	x	x	1	36	SCREW-pan, 8-32 x 1/4	80675	x	x	x	2
3	RING-retaining	76120	x	x	x	1	38	SCREW-shoulder	64133-A	x	x	x	3
4	RING-piston pin retaining	64818	x	x	x	1	*37	CAP-muffler	A-67827-1	x	x	x	1
5	ROD-connecting	A-67411	x	x	x	1	38	SCREW-shoulder (See Note 1)	64133-A	/	/	/	2
6	Includes. BEARING-needle	67408	x	x	x	1	39	CAP-muffler (See Note 1)	64126	/	/	/	1
7	SCREW	80880	x	x	x	2	40	BAFFLE-muffler (See Note 1)	64125	/	/	/	1
8	GASKET-crankcase	63361-A	x	x	x	1	41	SCREW-box, 12-24 x 1/2 (See Note 1)	80821	/	/	/	3
9	KEY-woodruff	76078	x	x	x	1	42	BODY-muffler (See Note 1)	A-64110	/	/	/	1
10	ROLLER-needle (set of 2)	A-67437	x	x	x	1	43	SPARK PLUG	83047-8	x	x	x	1
11	CRANKSHAFT	83204-1	x	x	x	1	44	Includes GASKET	26038	x	x	x	1
12	SCREW-bearing retainer	58704	x	x	x	2	46	CYLINDER	A-64622-2A	x			1
13	WASHER-special	63206	x	x	x	2		CYLINDER	A-67122-1	x			1
14	BEARING-ball	63865-8	x	x	x	1		CYLINDER	64406-1	x			1
15	RING-retaining	68018-A	x	x	x	1	45	LINE-oil (manual)	A-67078	x	x	x	1
16	DECAL	64144	x	x	x	1	47	FITTING-straight	86896	x	x	x	1
17	CAP-fuel filter	A-67901	x	x	x	1	48	CONNECTOR-elbow	31754	x	x	x	1
18	LINE-oil (auto, upper)	A-61918	x	x	x	1	49	NUT-hex, 1/4-28	51081-2	x	x	x	4
19	PUMP-automatic oil	A-67023	x	x	x	1	50	WASHER-lock, 1/4	83008	x	x	x	4
20	Includes. SCREW-pan	64102-A	x	x	x	1	51	PIN-compression release	A-67482	x	x	x	1
21	GASKET	68735	x	x	x	1	52	GASKET-cylinder	65828	x	x	x	1
22	SCREW-pan, 4-40 x 3/4	80919	x	x	x	2	53	STUD-cylinder (long)	63858	x	x	x	1
23	SEAL-felt	64393	x	x	x	1	54	PIVOT PIN & BRACKET ASSY	A-64688-2	x	x	x	1
24	SCREW-pan, 8-32 x 7/8	80568	x	x	x	1	55	SCREW-pan, 6-32 x 3/8	80671	x	x	x	1
25	WORM-oil pump	63258	x	x	x	1		SCREW-pan, 8-32 x 3/8	80573	x			2
26	LINE-oil (auto, lower)	A-61947	x	x	x	1	56	SPRING-relief valve	64653	x	x	x	1
27	"O" RING	59074	x	x	x	1	57	CLAMP-oil	65943-2	x	x	x	1
28	SEAL	63308-A	x	x	x	1	58	CLAMP-lever	64655-2	x	x	x	1
29	STUD-cylinder (short)	65871	x	x	x	3	59	WASHER-relief valve	84654-13	x	x	x	1
*30	MUFFLER-head (complete)	A-67828-A	x	x	x	1	60	FILTER-oil	A-64741	x	x	x	1
	Includes BODY-muffler	A-67446-1A	x	x	x	1	61	VALVE-check	A-62848	x	x	x	1
*31	SCREW-box, 12-24 x 1/2	80821	x	x	x	3	62	NUT-flexlock, 8-32	81126	x	x	x	4
*32	BAFFLE-muffler	87450	x	x	x	1		NUT-flexlock, 6-32	81126				4
*33	BAFFLE-muffler	87394	x	x	x	1							

* Denotes new parts

/ Optional

Note 1 - Used on International Units Only

HOMELITE XL CHAIN SAWS

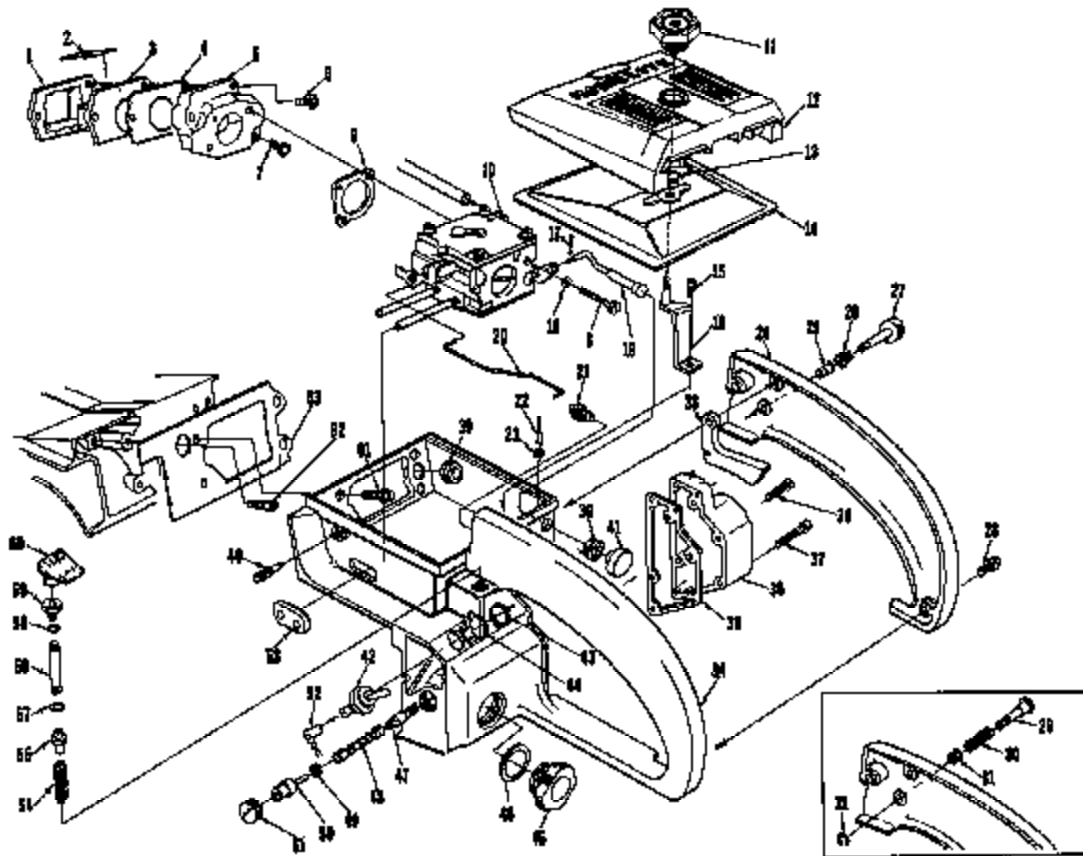

FIGURE 3

No.	Description	Part No.	XL-113	XL-114	XL-112	Qty.	No.	Description	Part No.	XL-113	XL-114	XL-112	Qty.
1	RETAINER-reed valve	64263	x	x	x	1	34	HANDLE-throttle	A-67697-A	x	x	x	1
2	REED-valve	58678-B	x	x	x	4		HANDLE-throttle	A-67698-A	x	x	x	1
3	BEAT-reed valve	64262	x	x	x	1		Includes RIVET-accordion (not shown)	03869	x	x	x	1
4	GASKET-reed valve seat	64266	x	x	x	1	35	GASKET-oil tank	07267	x	x	x	1
*5	MANIFOLD-intake	A-87602-A	x	x	x	1	36	COVER-oil tank	07148-3	x	x	x	1
6	Includes SCREW-pas, 8-32 x 1 1/4	82174	x	x	x	2	37	SCREW-flt, 8-32 x 1 5/8	82183	x	x	x	1
7	SCREW-pas, 8-32 x 1	82179	x	x	x	1	38	SCREW-flt, 8-32 x 3/4	82186	x	x	x	1
8	SCREW-hex, 10-32 x 1 7/8	82178	x	x	x	2	39	GROMMET	64862	x	x	x	1
9	GASKET-carburetor	67681	x	x	x	1	40	SCREW-Idle adjustment	64862	x	x	x	1
10	CARBURETOR	A-67681	x	x	x	1	41	SCREW-Idle adjustment	67288-3	x	x	x	1
11	NUT-cover mounting	A-87627	x	x	x	1	42	BUTTON-choke	A-03988	x	x	x	1
12	COVER-air filter	68189-2	x	x	x	1	43	SWITCH	72084-A1	x	x	x	1
13	ROD-retaining	58319-A	x	x	x	1	44	Includes. NUT	68010	x	x	x	1
14	FILTER ELEMENT-air	A-83955-A	x	x	x	1	45	PLATE-"On-Off"	A-05284	x	x	x	1
15	SCREW-hex, 12-24 x 1/2	80821	x	x	x	1	46	CAP-oil (vented)	65133	x	x	x	1
16	BRACKET-air filter cover	A-83876	x	x	x	1	46	Includes. "O" RING	64718	x	x	x	1
17	PIN-cotter	86124	x	x	x	1		VALVE-vent (not shown)	A-64263	x	x	x	1
18	WASHER-lock, #10	85046	x	x	x	2	47	FILTER-oil (manual)	64266	x	x	x	1
19	ROD-choke	A-63942-I	x	x	x	1	48	LINE-flexible oil	69726	x	x	x	1
20	ROD-throttle	63826-1	x	x	x	1	49	GASKET	A-68936	x	x	x	1
*21	ROD-throttle rod	67624	x	x	x	1	50	FITTING-bleed valve	69113	x	x	x	1
22	PIN-cotter	86801	x	x	x	1	51	SCREW-sec	A-63939	x	x	x	1
23	WASHER-felt	89280	x	x	x	1	52	LEAD-ground	66080	x	x	x	1
24	COVER-throttle handle	63589-3	x	x	x	1	53	GROMMET-"Hi-Lo"	60081	x	x	x	1
25	BUSHING-throttle lock	64846	x	x	x	1	54	SPRING-plunger	A-68188	x	x	x	1
26	SPRING-throttle lock	64877	x	x	x	1	55	PLUNGER-oil pump	67886	x	x	x	1
27	PIN-throttle lock	85592	x	x	x	3	56	SCREW-hex, 18-84 x 5/8	60678	x	x	x	1
28	SCREW-pas, 8-32 x 1/2	80660	x	x	x	2	57	VENT-fuel tank	A-68608	x	x	x	1
29	PIN-throttle lock	66984-I	x	x	x	1	58	GASKET-throttle handle	64267	x	x	x	1
30	SPRING-throttle lock	58406	x	x	x	1	59						
31	BUSHING-throttle lock	66004	x	x	x	1	59	NUT-plunger	67886	x	x	x	1
32	ROD-retaining	88408	x	x	x	1	60	BUTTON-oil pump	60678	x	x	x	1
33	TRIGGER-throttle	66212-A	x	x	x	1	61	SCREW-hex, 18-84 x 5/8	60678	x	x	x	1
							62	VENT-fuel tank	A-68608	x	x	x	1
							63	GASKET-throttle handle	64267	x	x	x	1

* Denotes new parts

ALWAYS FURNISH MODEL AND SERIAL NUMBER WHEN ORDERING PARTS.

HOMELITE XL CHAIN SAWS

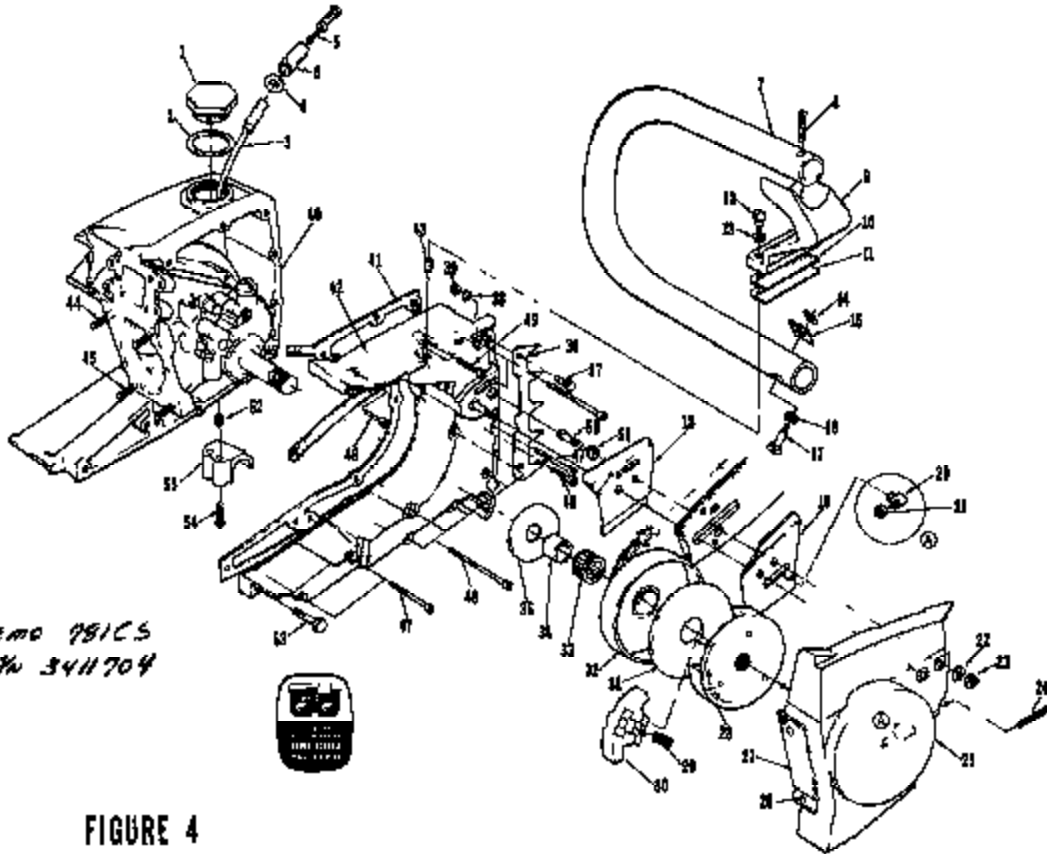

See Ser MEMO 781CS
Eff XL113 To 341704

FIGURE 4

No.	Description	Part No.	XL-113	XL-114	XL-122	Qty.	No.	Description	Part No.	XL-113	XL-114	XL-122	Qty.
1	CAP-fuel filler	A-67301	x	x	x	1	33	SPROCKET-3/8" pitch, 7 tooth	A-64908	/	/	/	1
2	Includes Gasket	68937	x	x	x	1	34	LEADING-edge	04324	x	x	x	1
3	LINK-fuel	6144	x	x	x	1	35	RACE-roller	62968	x	x	x	1
4	WASHER	64182	x	x	x	1	36	WASHER-thrust (inner)	63832-1	x	x	x	1
5	PISTON-Ring	A-61480	x	x	x	1	38	BUMPER-impact	A-64722	/	/	/	1
6	Includes PILLER-felt	64083	x	x	x	1	39	Includes Saw-cut bar, 12-24 x 5/8	60876	/	/	/	2
7	HANDLE-Bar	A-68877-1	x	x	x	1	40	WASHER-lock #72	83050	/	/	/	2
8	SCREW-screw, 10-32 x 1	82126	x	x	x	1	41	NU T-nut, 12-24	81008	/	/	/	2
9	BRACKET-1-handle bar	A-68866-1	x	x	x	1	42	CRANKCASE & TANK	668039	x	x	x	1
10	BAR-bracket	64610	x	x	x	1		Includes PIN-dowel (not shown)	71440	x	x	x	2
11	PLATE-handle bar bracket	63586	x	x	x	1		PIN-dowel (not shown)	63388	x	x	x	2
12	BEARING-shoulder	66614-A	x	x	x	2		BALL-See Pgs. 2, Index #88	08308-A	x	x	x	1
13	GRINDING-1-handle bar	64474	x	x	x	2		CARTRIDGE-fuel tank	66304-A	x	x	x	1
14	PLATE-handle bar	66870	x	x	x	1		Includes (not shown)	A-66876-A	x	x	x	1
15	PLATE-handle bar	66869	x	x	x	1	43	CARTRIDGE-check valve	58838	x	x	x	1
16	GRINDING-2-handle bar	67066	x	x	x	1	44	CAP-check valve	68339	x	x	x	1
17	SCREW-shoulder	64734	x	x	x	1	45	INNER-1-Liplock	92489	x	x	x	1
18	PLATE-guide bar (inner)	63618-B	x	x	x	1	46	STUD-cylinder (long)	63688	x	x	x	1
19	PLATE-guide bar (outer)	63638-A	x	x	x	1	47	STUD-cylinder (short)	55871	x	x	x	2
20	PIN-bar adjusting	65768-1	x	x	x	1	48	SCREW-fl, 8-32 x 1 1/16	82353	x	x	x	2
21	NU T-lock, 10-32	81211	x	x	x	1	49	SCREW-fl, 8-32 x 1 7/8	82354	x	x	x	1
22	WASHER-fl, 5/16	84032	x	x	x	4	50	SCREW-fl, 8-32 x 2 1/16	82355	x	x	x	7
23	NU T-hex, 5/16-18	81196	x	x	x	2	51	SCREW-fl, 8-32 x 1 1/4	82358	x	x	x	1
24	SCREW-guide bar adjusting	66844	x	x	x	1	52	STUD-guide bar	67143-63863	x	x	x	2
25	COVER-distributor	A-64680-1	x	x	x	1	53	INSERT-1-threaded	36886-A	x	x	x	2
26	Includes RIVET-curved lead	85061	x	x	x	2	54	INSERT-1-Liplock	72488	x	x	x	2
27	SHOULDER-sawcut	64618	x	x	x	1	55	SCREW-hex, 12-24 x 7/8	80881	x	x	x	1
28	PLATE-clutch	64904-1	x	x	x	1		Kit-handle bar stop	A-67700	x	x	x	1
29	SPRING-clutch	65842	x	x	x	1		Includes SCREW-pin, 10-32 x 5/8	80672	x	x	x	2
30	WHEEL-clutch	64880-1	x	x	x	1		HANDLE-handle bar	67506-2	x	x	x	1
31	COVER-clutch	65971	x	x	x	1							
32	WHEEL & HUB	A-65888	x	x	x	1							

*Homelite use parts

/ Optional

NOTE 1 - Units using A-64808 must use 63880 thrust washer, 61890 inner Race, 64328 Needle bearing.

HOMELITE XL CHAIN SAWS

SPECIAL TOOLS (available on order)

A-23937-B	WRENCH-combination
22820-5	COLLAR-bearing installation (bearing to shaft)
22828	PLIERS-retaining ring
23196-1	SLEEVE-bearing and shaft installation
23528	WRENCH-socket screw (connecting rod)
23756	PLUG-needle bearing (connecting rod)
23759	SLEEVE-seal protection (back plate)
23846-2	ANVIL-roller bearing disassembly
A-23934	SPANNER-clutch
A-23949	TOOL-piston pin removal
A-23980	BRACKET-rotor removal
23972	SLEEVE-seal installation
24006-2	PLATE-shaft alignment
A-24051	JACKSCREW (bearing to shaft to crankcase)
24054	PLUG-seal assembly (crankcase)
24055	PLUG-bearing and seal assembly (back plate)
A-24057	BEARING REMOVER-(back plate)
24076	SLEEVE-seal protecting (crankcase side)
A-24138	REAMER-compression release
24280	DRIVER-hand, pozidriv
24173	DRIVER-check valve installation
A-23841-A	WRENCH-insert
24304	BIT-pozidriv #2

Accessories

*A-68074	SPARK ARRESTER-(Reed Muffler)
65548-1	HEAT EXCHANGER
A-64818	SPARK ARRESTER-Note 1

Paint

24101	SPRAY CAN-dark blue
23475	SPRAY CAN-red

*Denotes new parts

NOTE 1 - Used on International Units only

HOMELITE XL CHAIN SAWS

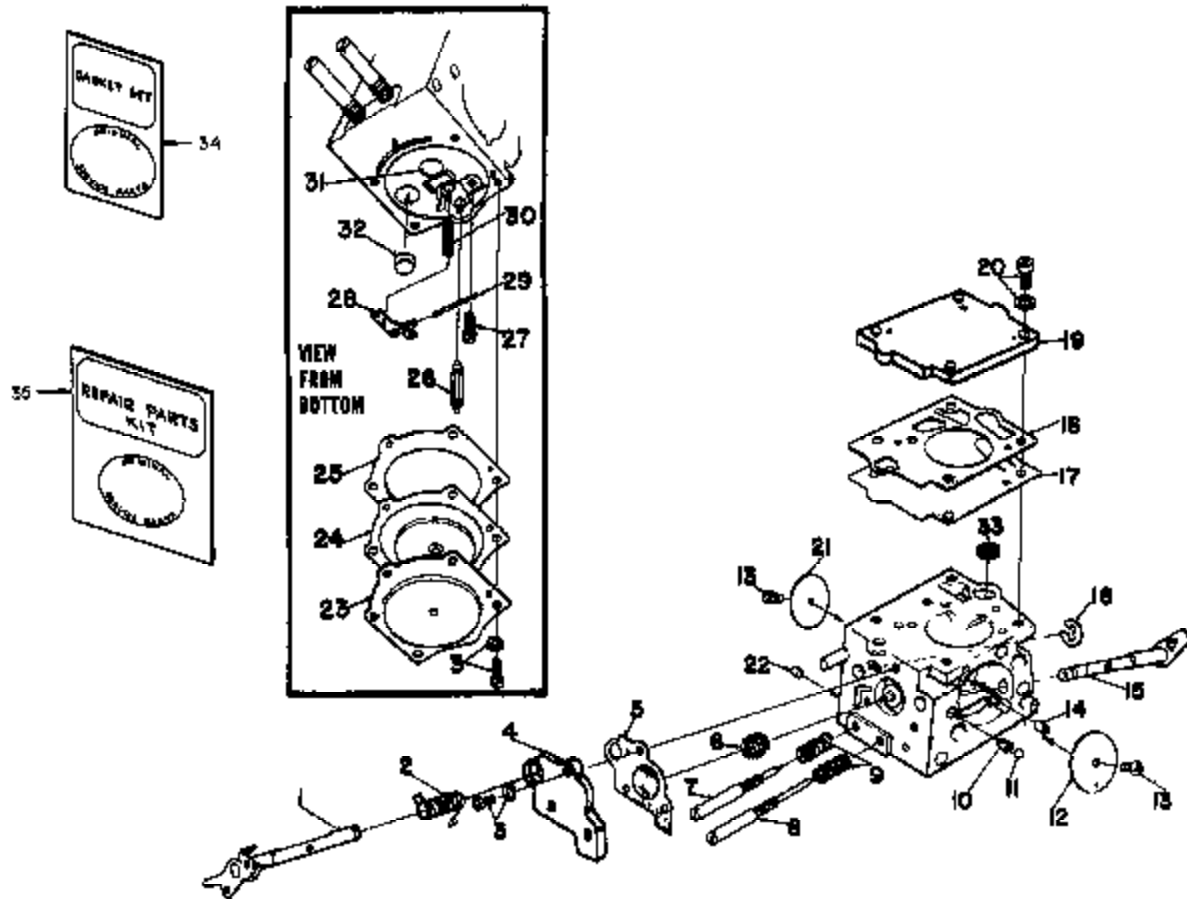

No.	Description	Part No.	Qty.	No.	Description	Part No.	Qty.
1	THROTTLE SHAFT ASSEMBLY	64225	1	19	COVER-fuel pump	67002	1
2	SPRING-throttle return	64239	1	20	SCREW-fuel pump cover	64694	4
3	SCREW ASSEMBLY	64689	7	*21	VALVE-throttle	67700	1
4	COVER-accelerator	67187	1	22	PLUG-limiting	64692	1
5	DIAPHRAGM-accelerator pump	67189	1	23	COVER	64224	1
6	SPRING-accelerator pump	64240	1	24	METERING DIAPHRAGM ASSEMBLY	64235	1
7	NEEDLE-idle	64241	1	25	GASKET-metering diaphragm	64231	1
8	NEEDLE-high speed	64242	1	26	VALVE-inlet needle	64229	1
9	SPRING-needle adjusting	64238	2	27	SCREW-metering lever pin	64668	1
10	SPRING-choke friction	64238	1	28	LEVER-metering	64245	1
11	BALL-choke friction	60051	1	29	PIN-metering lever	64244	1
12	VALVE-choke	64229	1	30	SPRING-metering lever	64237	1
13	SCREW-valve	64693	2	31	PLUG-valve (main)	66452	1
14	JET-idle air	64690	1	32	PLUG-valve (idle)	63018	1
15	CHOKE SHAFT ASSEMBLY	64227	1	33	SCREEN-fuel inlet	64243	1
16	RING-throttle shaft retaining	64221	1	34	GASKET SET	67013	1
17	DIAPHRAGM-fuel pump	64233	1	35	REPAIR KIT	67187	1
18	GASKET-fuel pump	67008	1		REPAIR KIT-check valve	65386	1

†Included in Repair Kit 67187
 *Denotes new parts.

HOMELITE XL CHAIN SAWS

Part No.	Description	Qty.	Part No.	Description	Qty.	Part No.	Description	Qty.	Part No.	Description	Qty.
22820-5	Collar	1	63716	Valve	2	A-64620-1	Cover	1	67285	Clamp	1
22826	Flora	1	63851	Stud	2	64644	Bushing	1	A-67287	Plate	1
23136-1	Sleeve	1	63855-B	Bearing	1	64653	Spring	1	67290	Proton Ring	1
23475	Paint-red	1	63858	Stud (long)	1	64654	Lever	1	67385	Button	1
23528	Wrench	1	63859	Rope	1	64655-2	Clamp	1	*67394	Reed-muff.	1
23758	Plug	1	63870	Spring	1	A-64656-2	Pivot Pin	1	67395	Bearing	1
23759	Sleeve	1	63875	Ring	1	64677	Spring	1	67403	Bearing	1
A-23841-A	Wrench	1	63877	Stud	2	64686	Screw	1	A-67411	Rod	1
23846-2	Anvil	1	63880-1	Rod	1	64689	Screw	7	*67413-1	Stop	1
A-23894	Wrench	1	63905	Washer	2	64690	Jet	1	A-67437	Bearing	1
A-23937-B	Wrench	1	A-63919	Loop	1	64692	Plug	1	*A-67446-1A	Body-muff.	1
A-23948	Plug	1	A-63920	Filter	1	64693	Screw	2	*67450	Rifle	1
A-23960	Puller	1	A-63930	Fitting	1	64694	Screw	4	A-67462	Valve	1
23972	Sleeve	1	63910	Plate	1	A-64722	Kit-bumper	1	67463	Lead-transfer	1
24006-2	Plate	1	A-63929	Cover	1	A-64741	Filter	1	67484	Lead-transfer	1
A-24051	Jackcrew	1	A-63938	Swab	1	64754	Screw	1	A-67501	Cap	1
24054	Plug	1	A-63939	Lead	1	A-64797-D	Crankcase	1	*A-67502-A	Mainfold	1
24065	Plug	1	A-63942-1	Rod	1	64813	Ring	1	67503-2	Stop	1
A-24057	Plug	1	A-63947	Lens	1	A-64815	Arrestor	1	*A-67527-1	Cap	1
24078	Sleeve	1	A-63952-A	Pulley	1	64962	Grommet	2	A-67627	Nut	1
24101	Paint-blue	1	A-63955-A	Filter	1	64904-1	Plate	1	67631	Gasket	1
A-24128	Reamer	1	63980	Race	1	A-64908	Sprocket	1	*67634	Boot	1
24173	Driver	1	64021	Screw	2	64948	Lock	1	A-67681	Carburetor	1
24220	Driver	1	64023-1	Element	1	A-64949	Spring	1	A-67686	Proton & Pin	1
24304	Bit	1	64028	Screw	2	65081	Plunger	1	A-67697	Handle	1
24308	Gasket	1	64030	Condensor	1	65092	Nut	1	A-67698	Handle	1
24308	Clip	1	A-64037	Pointe	1	65123	"O" Ring	1	67720	Valve	1
24323	Washer	1	64038	Block	1	A-65128	Rod	1	*A-67706	Kit-stop	1
30812	Plug	1	64039	Pell	1	A-65224	Cap	1	*A-67828-A	Muffler	1
31734	Connector	1	64080	Screw	2	65221	Screw	5	*A-68074	Spark Arrestor	1
A-33055	Terminal	1	64081	Coil	1	65354	Gasket	1	OM68210	Sprocket	1
54422	Core	1	64102-A	Screw	1	65355	Pin	2	71430	Pin	2
54423	Clip	1	64124	Bearing	1	65388	Repair Kit	1	72488	Invert	1
54411	Screw	2	64125	Cap	1	65482	Plug	1	78078	Key	1
54697	Stud	3	64126	Baffle	1	65491	Screw	1	78120	Ring	1
57299-1	Button	1	A-64130	Body	1	65522	Screw	1	78423	Screw	2
58006-A	Seal	1	64133-A	Screw	5	65543-1	Exchanger	1	FASTENING PARTS		
58118-A	Ring	2	64164	Invert	1	A-65559-1	Handle Bar	1	80189	8-32 x 7/8	2
58338	Gasket	2	64155	Grip	1	65569	Pad	1	80560	8-32 x 1/2	2
58338	Cap	1	64182	Washer	1	A-65576-A	Cover	1	80571	6-32 x 3/8	3
58405	Spring	1	64221	Ring	1	65585	Plate	1	80572	10-32x3/8	4
58408	"O" Ring	2	64224	Cover	1	65592	Pin	1	80575	8-32 x 1/2	2
58408	Ring	1	64225	Throttle	1	A-65608	Vent	1	80605	6-32 x 5/16	1
58488-A	Seal	1	64227	Choke	1	A-65666-1	Bracket	1	80648	10-32 x 1/2	1
58768-2	Spring	2	64228	Valve	1	65670	Plate	1	80676	12-24 x 5/8	2
58833-1	Washer	1	64229	Valve	1	65830	Fitting	1	80821	12-24 x 1/2	1
58851	Washer	2	64231	Gasket	1	65769-1	Pin	1	80889	8-36 x 1/2	2
58854	Grommet	1	64233	Diaphragm	1	65829	Gasket	1	80891	12-24 x 7/8	1
58924-1	Pin	1	64235	Metering	1	65842	Spring	3	80910	4-40 x 1/4	2
58957	Gasket	1	64236	Spring	2	65889	Rivet	2	80953	8-32 x 1/2	4
58986	Lead	1	64237	Spring	1	65944	Screw	1	81065-2	Nut-1/4-28	4
59064	Bushing	1	64238	Spring	1	A-65948	Valve	1	81068	Nut-12-24	2
59074	"O" Ring	1	64239	Spring	1	65948-2	Clamp	1	81112	Nut-5/16-24	1
59178-B	Reed	4	64240	Spring	1	65955	Race-inner	1	81126	Nut-6-32	2
59204	Screw	2	64241	Needle	1	A-65988	Drum & Hub	1	81196	Nut-5/16-38	2
59236	Gasket	2	64242	Needle	1	67002	Cover	1	81211	Nut-10-32	1
59286-A	Invert	2	64243	Screw	1	67008	Gasket	1	88128	10-32 x 1	1
60051	Ball	1	64244	Pin	1	67019	Gasket	1	82161	8-32 x 15/16	2
60119	Screw	1	64245	Lever	1	A-67023	Housing	1	82162	8-32 x 1 1/4	1
60188-2	Cover	1	64252	Seat	1	67068	Grommet	1	82159	8-32 x 1 5/8	3
63204-1	Crankschaft	1	64253	Retainer	1	A-67079	Lens	1	82164	8-32 x 1 7/8	1
63210-A	Trigger	1	64264	Gasket	1	67198-1	Cover	3	82155	8-32 x 2 3/16	1
63228	Worm	1	64267	Gasket	1	67197	Bushing	1	82156	8-32 x 1/1	1
63230	Washer	1	A-64283	Filter	1	67185	Washer	1	82173	8-32 x 1	1
63261-A	Gasket	1	64301	Retainer	1	67187	Cover	1	82174	8-32 x 1 1/4	2
63344	Lens	1	64333	Bearing	1	67188	Diaphragm	1	82177	8-32 x 6/8	2
63347-B	Plug	1	64350	Lens	1	A-67189-1	Cylinder	1	82178	8-32 x 1/1	2
A-63378	Bracket	1	64374	Bushing	1	67191	Stud	4	82179	10-32 x 1 7/8	1
63388-2	Cover	1	64393	Seal	1	A-67192-A	Housing	1	83009	Washer-1/4	1
63608	Washer	1	64405-1	Cylinder	1	67187	Repair Kit	1	83046	Washer-F10	2
63624-1B	Plate	1	64423	Cap	1	67222	Ring	1	83056	Washer-F12	2
63637	Rotor	1	64442	Pin	2	67225	Gasket	1	83106	Washer-F8	4
63639-B	Plate(inner)	1	64474	Grommet	2	67226	Pin	1	83900	Washer	1
63639-A	Plate(outer)	1	A-64522-2A	Cylinder	1	67227	Core	1	83018	Washer-F6	2
63671	Cover	1	64569-1	Shoe	1	67280	Lead	1	84034	Washer-5/16	2
63713	Shield(inner)	1	64610	Pad	1	67281	Condensor	1	84065-1	Washer-5/16	1
63714	Shield(outer)	1	64614-A	Screw	2	67282	Module	1	86301	Pin-cutter	1
						67284	Rotor	1	86324	Pin-cutter	1

*Denotes new parts

ALWAYS FURNISH MODEL AND SERIAL NUMBER WHEN ORDERING PARTS.

HOMELITE®
A **EXLON** DIVISION
FORT CHESTER, N. Y., U.S.A.

PRINTED IN U.S.A.

170

