

Ersatzteilliste
Spare parts list
Liste de pièces de rechange
ista de piezas de recambio

Motorsägen
Chain saws
Tronçonneuses
Motosierras

662 / 667 / 667 SP

**MADE
 BY
 SOLO**
 MADE IN GERMANY



Zeichenerklärung Legend

○XXXXX Bis Serien-Nr.
 Ab Serien-Nr.
 XXXXX○ Neues Teil gegenüber D 9 662 710
 + Neues Teil gegenüber D 9 662 710,
 mit Bezug auf Serien-Nr.
 *+

up to serial no.
 as of serial no.
 new part compared to D 9 662 710
 new part compared to D 9 662 710,
 referring to serial no.

Légende

jusqu'au no. de série
 à partir de no. de série
 nouvelle pièce par rapport à D 9 662 710
 nouvelle pièce par rapport à D 9 662 710,
 se référant au no. de série

Leyenda

hasta no. de serie
 desde de no. de serie
 parte nuevo comparado con D 9 662 710
 parte nuevo comparado con D 9 662 710
 referente al no. de serie

D 9 662 711

solo®

Zubehör/
 Attachments /
 Accessoires/
 Los Accesorios

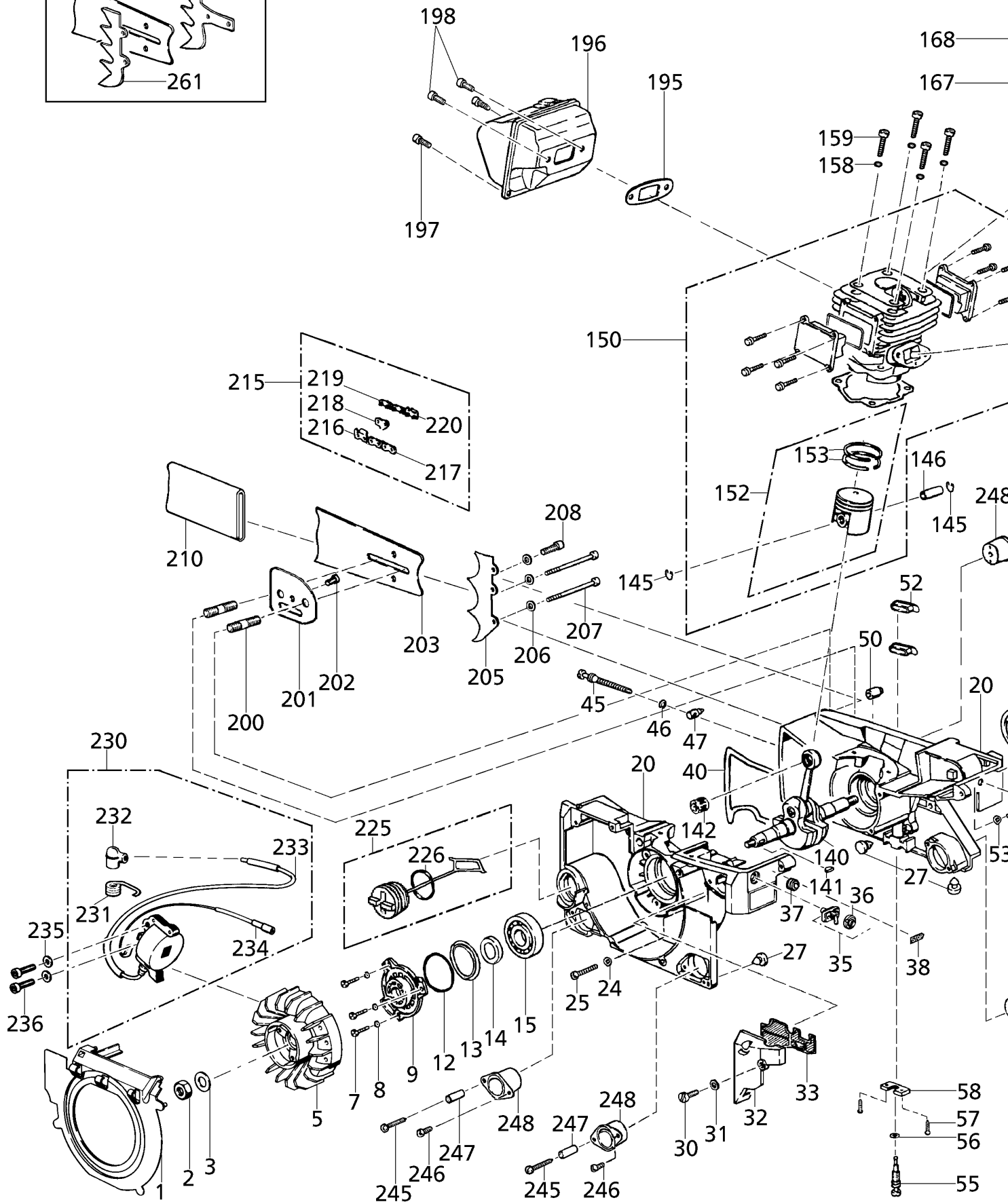
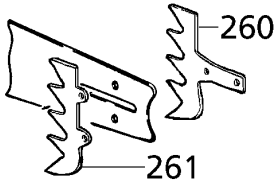

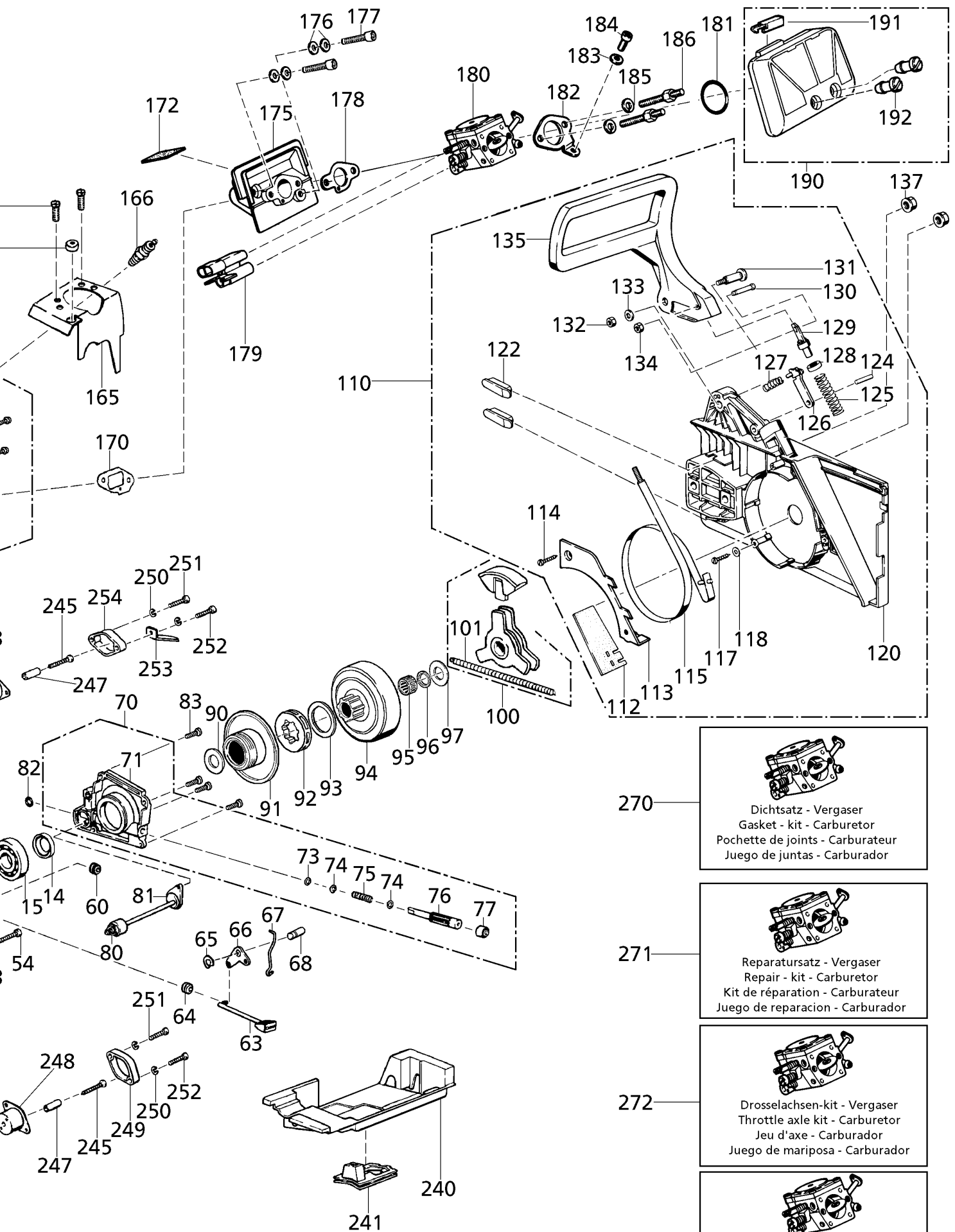

270

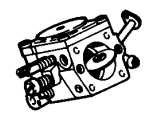

Dichtsatz - Vergaser
 Gasket - kit - Carburetor
 Pochette de joints - Carburateur
 Juego de juntas - Carburador

271

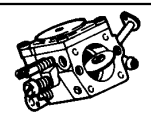

Reparatursatz - Vergaser
 Repair - kit - Carburetor
 Kit de réparation - Carburateur
 Juego de reparación - Carburador

272

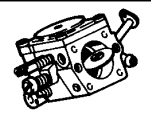

Drosselachsen-kit - Vergaser
 Throttle axle kit - Carburetor
 Jeu d'axe - Carburateur
 Juego de mariposa - Carburador

273

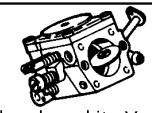

Chokeachsen-kit - Vergaser
 Choke axle kit - Carburetor
 Jeu d'étrangleur - Carburateur
 Juego eje choke - Carburador

Bild-Nr. Pos.-No. Pos.-No. Pos.-No.	Bestell-Nr. Order-No. No. de Cde. Ref.-Nr.	Modell Type Modèle Modelo	Menge Quantity Nombres Cantidad	Motor/ Gehäuse	Engine/ Housing	Moteur/ Carter	Motor/ Carter
1	60 73 489		1	Luftführung	air conduct	conduite d'air	guia aire
2	00 20 145		1	Sechskantmutter M8x1 ISO 8673	nut	écrou	tuerca
3	00 72 145		1	Spannscheibe 8 DIN 6796 A	tension washer	rondelle de tension	arandela elastica
5	24 00 265		1	Lüfterrad PVL	fan wheel, PVL	volant magnétique, PVL	turbina, PVL
5	24 00 301 *+		1	Lüfterrad, DUCATI	fan wheel, DUCATI	volant magnétique, DUCATI	turbina, DUCATI
7	00 11 267		3	Zylinderschraube M5x12 DIN 84	screw	vis	tornillo
8	00 72 140		3	Tellerfeder 12,5x5,2x0,6 DIN 2093	spring washer	rondelle ressort	muelle de disco
9	60 74 389		1	Generatöraufnahme	generator seat	carter génératrice	soporte generador
12	00 62 253		1	O-Ring 34x2,3	o-ring	joint torique	anillo
13	60 74 363		1	Stützscheibe 31,3x39,8/34,4x3,5/1	support washer	rondelle support	disco
14	00 54 247		2	Wellendichtring 17x28x5	oil seal	joint spil	anillo de junta del arbol
15	00 50 202		2	Kugellager 17x40x12	ball bearing	roulement	cojinete de bolas
20	21 00 470		1	Kurbelgehäuse A5+Z5 (inkl. Pos. 50)	crankcase, compl. (incl. pos. 50)	carter de moteur, compl. (incl. pos. 50)	carter del cigüenal (incl. pos. 50)
24	00 34 147		4	Federring 5 DIN 128 A	spring ring	rondelle élastique	anillo elástico
25	00 10 134		4	Zylinderschraube M5x30 DIN 912	screw	vis	tornillo
27	00 94 294		3	Anschlagpuffer	buffer	butoir	tope
30	00 10 177		1	Zylinderschraube M5x16 DIN 84	screw	vis	tornillo
31	00 30 108		1	Scheibe 5,3 DIN 125 B	washer	rondelle	arandela
32	20 74 377		1	Vorfilterdeckel	pre-filter cover	couvercle filtre	filtro
33	25 00 541		1	Vorfilter, kompl.	pre-filter, compl.	filtre	filtro
35	23 00 469		1	Kurzschlußschalter	short circuit switch	interrupteur	interruptor
36	00 21 232		1	Rundmutter M12x0,75	nut, round	écrou, rond	tuerca
37	00 66 197		1	Kabeltülle	grommet	passe-fil	manguito de cable
38	00 69 553		1	Klebeschild "STOP"	decal "STOP"	autocollant "STOP"	etiqueta "STOP"
40	20 61 428		1	Kurbelgehäusedichtung, 0,3 mm dick	crankcase gasket	joint carter	junta del carter
45	00 18 261		1	Spannschraube M6x53/70	tension screw	vis de tension	tornillo
46	00 55 171		1	Sicherungsscheibe 5 DIN 6799	safety washer	rondelle sécurité	disco
47	30 32 638		1	Kettenspannbolzen M6x6/9	chain tension bolt	vis de tension, chaîne	tensor de cadena
50	27 00 382		1	Rückschlagventil, grün	check valve, green	soupape antiretour, verte	valvula de retención
52	60 74 281		2	Gleitschuh	guide shoe	sabot	patin
53	00 34 147		1	Federring 5 DIN 128 A	spring ring	rondelle élastique	anillo elastico
54	00 10 260		1	Zylinderschraube M5x16 DIN 912	screw	vis	tornillo
55	64 00 179		1	Hubstift 3/5,8x14/33	pin	goujon	perno
55	60 31 222 *+		1	Hubstift 8x33,5	pin	goujon	perno
56	00 62 110		1	O-Ring 7x1,5	o-ring	joint torique	anillo
57	00 18 231		2	Schraube 4x13	screw	vis	tornillo
58	22 00 871		1	Anschlagstück	stop plate	butée	pieza
58	60 74 254 *++		1	Anschlagstück	stop plate	butée	pieza
60	60 74 401		1	Verschlußstopfen M14x1,5	plug	bouchon	tapon
63	60 74 253		1	Chokehebel	choke lever	levier de starter	palanca choke
64	00 66 440		1	Chokehebeltülle 5,5x10x2,3x14	grommet	passe-fil	manguito de cable
65	00 55 103		1	Sicherungsscheibe 3,2	safety washer	rondelle sécurité	disco
66	60 74 396		1	Umlenkhebel	lever	levier	palanca
67	20 36 373		1	Chokegestänge	linkage	tringle	varillaje
68	60 31 229		1	Achse 5x16 Hebel	axle	axe	eje
70	64 00 210		1	Ölpumpe, kompl. (enth.: Öl-Pumpengehäuse, kompl.	oil pump, compl. (incl.: pump housing, compl.	pompe à huile, compl. (incl.: carter de pompe, compl.	bomba de aceite, compl. (incl.: carter del bomba, compl.
(71)	64 00 211		1	Öl-Pumpengehäuse, kompl.	pump housing, compl.	carter de pompe, compl.	carter del bomba, compl.
(73)	00 62 284		1	O-Ring 6,5x1	o-ring	joint torique	anillo
(74)	00 31 515		2	Anlaufscheibe 71x10x0,3	washer	rondelle	disco
(75)	00 70 257		1	Druckfeder 0,7x7,9x27	spring	ressort	resorte presion
(76)	60 31 189		1	Pumpenkolben	pump piston	piston de pompe	piston de bomba
(77)	60 74 452		1	Verschlußstopfen	plug	bouchon	tapon
71	64 00 211		1	Öl-Pumpengehäuse, kompl.	pump housing, compl.	carter de pompe, compl.	carter del bomba, compl.
73	00 62 284		1	O-Ring 6,5x1	o-ring	joint torique	anillo
74	00 31 515		2	Anlaufscheibe 71x10x0,3	washer	rondelle	disco
75	00 70 257		1	Druckfeder 0,7x7,9x27	spring	ressort	resorte presion
76	60 31 189		1	Pumpenkolben	pump piston	piston de pompe	piston de bomba
77	60 74 452		1	Verschlußstopfen	plug	bouchon	tapon
80	67 00 124		1	Ölsieb	oil strainer	tamis à huile	tamiz de aceite
81	60 63 329		1	Ölschlauch	oil hose	tuyau d'huile	tubo de aceite
82	00 62 237		1	O-Ring 4x9x3	o-ring	joint torique	anillo
83	00 11 267		4	Zylinderschraube M5x12 DIN 84	screw	vis	tornillo
91	00 31 276		1	Anlaufscheibe 14x24x1	washer	rondelle	arandela de arranque
92	34 00 204		1	Mitnehmer, Power Mate	activator	entraîneur powermate	activador
93	00 31 512		1	Scheibe 26x37x0,5 DIN 988	washer	rondelle	arandela
94	35 00 359		1	Kupplungsglocke 3/8" Power Mate	clutch drum 3/8"	cloche embrayage 3/8"	campana embrague 3/8"
95	00 52 143		1	Nadelkäfig 14x18x13	needle bearing	douille	casquillo de cojinete
96	00 61 223		1	Filzring 14x18x0,8	felt ring	joint	anillo de fieltro
97	00 31 526		1	Anlaufscheibe 10x25x1	washer	rondelle	arandela de arranque
100	35 00 365		1	Fliehkraftkupplung (enth.: Kupplungsfeder 1,3x4,5x149	clutch (incl.: clutch spring	embrayage (incl.: ressort d'embrayage	embrague centrifugal (incl.: resorte de embrague
(101)	00 71 215		1	Kupplungsfeder 1,3x4,5x149	clutch spring	ressort d'embrayage	resorte de embrague
-	00 69 605			Klebeschild)	decal	autocollant)	etiqueta)

Bild-Nr. Pos.-No. Pos.-No. Pos.-No.	Bestell-Nr. Order-No. No. de Cde. Ref.-Nr.	Modell Type Modèle Modelo	Menge Quantity Nombres Cantidad	Motor/ Gehäuse	Engine/ Housing	Moteur/ Carter	Motor/ Carter
101	00 71 215		1	Kupplungsfeder 1,3x4,5x149	clutch spring	ressort d'embrayage	resorte de embrague
110	61 00 316		1	Schwertabdeckung, kompl.	chain guard, compl.	carter chaîne, compl.	cubierta espada, compl.
112	00 94 256		1	Prallschutz	baffle protection	silentbloc	proteccion de impacto
113	60 74 394		1	Bremsbandabdeckung	brake band cover	couvercle bandeau	cubierta del cinta de freno
114	00 18 231		1	Schraube 4x13	screw	vis	tornillo
115	62 00 129		1	Bremsband	brake band	bandeau frein	cinta del freno
117	00 13 243		1	Linseblechschrabe 3,5x13 DIN 7981 C	screw	vis	tornillo
118	00 30 115		1	Scheibe 4,3 DIN 9021	washer	rondelle	arandela
120	61 00 305		1	Schwertabdeckung	chain guard	carter chaîne	cubierta espada
122	60 74 281		2	Gleitschuh	guide shoe	patin	patin
124	00 40 102		1	Zylinderstift 5M6 x 16 DIN 7	pin	vis	perno cilindrico
125	00 70 254		1	Druckfeder 1,6x10,2x56	spring	ressort	resorte
126	63 00 175		1	Druckblech	pressure plate	tôle	chapa de presión
127	00 70 253		1	Druckfeder 1,5x7x21,5	spring	ressort	resorte
128	00 33 311		1	Distanzrohr 12x2,5x2,5	spacer	entretoise	tubo espaciador
129	63 00 174		1	Verstellung	adjuster	réglage	regulación
130	60 32 670		1	Schaltbolzen M4x30,6	bolt	boulon	perno
131	60 32 594		1	Lagerbolzen M5	bolt	boulon	perno de cojinete
132	00 28 137		1	Sicherungsmutter M5 DIN 980	lock nut	contre-écrou	tuerca de seguridad
133	00 72 140		1	Tellerfeder 12x5,2x0,6 DIN 2093	spring washer	ressort	muelle de disco
134	00 28 118		1	Sicherungsmutter M4 DIN 980	lock nut	contre-écrou	tuerca de seguridad
135	60 73 445		1	Handschutz	hand protection	protege main	proteccion de mano
137	00 20 214		2	Sechskantmutter M8 DIN 4032	nut	écrou	tuerca
140	22 00 952		1	Kurbelwelle, kompl.	crankshaft, compl.	vilebrequin, compl.	cigüenal
141	00 75 101		1	Scheibenfeder 3x3,7 DIN 6888	spring washer	rondelle ressort	disco
142	00 52 148		1	Nadelkäfig 12x5x15	needle bearing	roulement à aiguilles	jaula de agujas
145	00 55 266		2	Kolbenbolzensicherung 12x0,8 DIN 7130	piston pin circlip	circlip	seguro del bulón
146	20 31 233		1	Kolbenbolzen 12/8x32	piston pin	axe de piston	bulón
150	22 00 991	662	1	Nikasilzylinder, Ø 46 mm mit Kolben, kompl.	cylinder with piston, compl.	cylindre avec piston, compl.	cilindro con piston, compl.
150	22 00 884	667 / 667SP	1	Nikasilzylinder, Ø 48 mm mit Kolben, kompl.	cylinder with piston, compl.	cylindre avec piston, compl.	cilindro con piston, compl.
152	22 00 984	662	1	Kolben mit Kolbenring, Ø 46 mm	piston with piston ring	piston avec segment	piston con anillo de piston
152	22 00 883	667	1	Kolben mit Kolbenring, Ø 48 mm	piston with piston ring	piston avec segment	piston con anillo de piston
152	22 00 954	667SP	1	Kolben mit Kolbenring, Ø 48 mm	piston with piston ring	piston avec segment	piston con anillo de piston
153	20 48 324	662	2	Kolbenring Ø 46x1,5	piston ring	segment	anillo de piston
153	20 48 326	667 / 667SP	2	Kolbenring Ø 48x1,5	piston ring	segment	anillo de piston
158	00 34 202		4	Schnorricherung 6	circlip	rondelle d'arrêt	arandela estriada
159	00 10 145		4	Zylinderschraube M6x35 DIN 912	screw	vis	tornillo
165	20 43 342		1	Luftführungsblech	air deflector plate	tôle de guidage d'air	chapa guia aire
166	23 00 730		1	Zündkerze WSR 6 F 200	spark plug	bougie	bujia
167	00 66 197		1	Kabeltülle	grommet	passe-fil	manguito de cable
168	00 10 360		2	Sechskantschraube M4x8	screw	vis	tornillo
170	20 61 430		1	Vergaserstutzendichtung, 0,5 mm dick	manifold gasket	joint d'admission	junta boquilla carburador
172	00 61 342		1	Klebefilz 8x18x3	felt	feutre adhésif	fieltro
175	23 00 658		1	Vergaserstutzen	manifold	pipe d'admission	boca de carburador
176	00 34 201		4	Sicherungsschreibe 5	circlip	rondelle élastique	anillo circlip
177	00 10 567		2	Zylinderschraube M5x28 DIN 912	screw	vis	tornillo
178	20 61 432		1	Vergaserdichtung, 0,5 dick	manifold gasket	joint carburateur	junta carburador
179	20 74 390		1	Düsenführung	guide piece, carburetor	guide vis de régl.	guia tobera
180	23 00 714		1	Vergaser WALBRO HDA 130	carburetor HDA 130	carburateur HDA 130	carburador HDA 130
180	23 00 780 ***		1	Vergaser WALBRO HDA 158	carburetor HDA 158	carburateur HDA 158	carburador HDA 158
181	00 62 246		1	O-Ring 30x2,5	o-ring	joint torique	anillo
182	60 43 311		1	Vergaserstütze	carburetor support	tôle	soporte
183	00 34 201		1	Sicherungsscheibe 5	circlip	rondelle élastique	anillo circlip
184	00 10 157		4	Zylinderschraube M5x10 DIN 912	screw	vis	tornillo
185	00 34 201		2	Sicherungsscheibe 5	circlip	rondelle élastique	anillo circlip
186	00 15 279		2	Stiftschraube M5x46	screw	vis	tornillo prisionero
190	25 00 620		1	Luftfilter, kompl.	air filter, compl.	filtre à air, compl.	filtro de aire, compl.
191	00 73 391		1	Klemmprofil 3x20	profile	profil	perfil
191	20 74 946 *+		1	Klemmprofil 4x2x20	profile	profil	perfil
192	00 11 282		2	Filterschraube M5x12,5	screw	vis	tornillo
195	20 61 431		1	Auspuffdichtung, 0,8 mm dick	exhaust gasket	joint d'échappement	junta del escape
196	25 00 611		1	Auspuff, kompl.	muffler, compl.	échappement, compl.	escape mont.
197	00 18 336		2	Zylinderschraube M5x16	screw	vis	tornillo
198	00 18 346		2	Zylinderschraube M6x16	screw	vis	tornillo
200	00 18 256		2	Schwertschraube M6x26,3	screw	vis	tornillo
201	60 42 724		1	Kettenschutzblech	chain protection plate	tôle intermédiaire	chapa
202	00 10 478		1	Zylinderschraube B 3,5x6,5 DIN 7971	screw	vis	tornillo
203	69 00 368	662		Führungsschiene, 40 cm (16"); 3/8"; Teilung=1,5	guide bar 40 cm (16"); 3/8";G=1,5	guide 40 cm (16"); 3/8";P=1,5	espada 40 cm (16"); 3/8";P=1,5
203	69 00 498			Führungsschiene, 45 cm (18"); 3/8"; Teilung=1,5	guide bar 45 cm (18"); 3/8";G=1,5	guide 45 cm (18"); 3/8";P=1,5	espada 45 cm (18"); 3/8";P=1,5

Bild-Nr. Pos.-No. Pos.-No. Pos.-No.	Bestell-Nr. Order-No. No. de Cde. Ref.-Nr.	Modell Type Modèle Modelo	Menge Quantity Nombres Cantidad	Motor/ Gehäuse	Engine/ Housing	Moteur/ Carter	Motor/ Carter
203	69 00 370			Führungsschiene, 50 cm (20"); 3/8"; Teilung=1,5	guide bar 50 cm (20"); 3/8";G=1,5	guide 50 cm (20"); 3/8";P=1,5	espada 50 cm (20"); 3/8";P=1,5
203	69 00 372	667/667SP		Führungsschiene, 60 cm (24"); 3/8"; Teilung=1,5	guide bar 60 cm (24"); 3/8";G=1,5	guide 60 cm (24"); 3/8";P=1,5	espada 60 cm (24"); 3/8";P=1,5
203	69 00 937	667/667SP		Führungsschiene, 70 cm (28"); 3/8"; Teilung=1,5	guide bar 70 cm (28"); 3/8";G=1,5	guide 70 cm (28"); 3/8";P=1,5	espada 70 cm (28"); 3/8";P=1,5
205	60 42 768		1	Anschlagkralle innen	bucking spike	griffe	garra de apoyo
206	00 34 147		3	Federring 5 DIN 128 A	spring ring	rondelle élastique	anillo elástico
207	00 10 559		2	Zylinderschraube M5x65 DIN 912	screw	vis	tornillo
208	00 11 267		1	Zylinderschraube M5x12 DIN 84	screw	vis	tornillo
210	60 71 248		1	Kettenschutz 40/50 cm (16"/20")	chain protection 40/50 cm (16"/20")	fourreau de chaîne 40/50 cm (16"/20")	proteccion cadena 40/50 cm (16"/20")
215	69 00 369	662		Vollmeißelkette 40 cm (16"); 3/8"; T=1,5; 60 Treibglieder, "Oregon Super Guard"	chain 40 cm (16"); 3/8";G=1,5	chaîne 40 cm (16"); 3/8";P=1,5	cadena 40 cm (16"); 3/8";P=1,5
215	69 00 369S	662		Vollmeißelkette 40 cm (16"); 3/8"; T=1,5; 60 Treibglieder, "SOLO"	chain 40 cm (16"); 3/8";G=1,5	chaîne 40 cm (16"); 3/8";P=1,5	cadena 40 cm (16"); 3/8";P=1,5
215	69 00 499			Vollmeißelkette 45 cm (18"); 3/8"; T=1,5; 68 Treibglieder, "Oregon Super Guard"	chain 45 cm (18"); 3/8";G=1,5	chaîne 45 cm (18"); 3/8";P=1,5	cadena 45 cm (18"); 3/8";P=1,5
215	69 00 499S			Vollmeißelkette 45 cm (18"); 3/8"; T=1,5; 68 Treibglieder, "SOLO"	chain 45 cm (18"); 3/8";G=1,5	chaîne 45 cm (18"); 3/8";P=1,5	cadena 45 cm (18"); 3/8";P=1,5
215	69 00 371			Vollmeißelkette 50 cm (20"); 3/8"; T=1,5; 72 Treibglieder, "Oregon Super Guard"	chain 50 cm (20"); 3/8";G=1,5	chaîne 50 cm (20"); 3/8";P=1,5	cadena 50 cm (20"); 3/8";P=1,5
215	69 00 371S			Vollmeißelkette 50 cm (20"); 3/8"; T=1,5; 72 Treibglieder, "SOLO"	chain 50 cm (20"); 3/8";G=1,5	chaîne 50 cm (20"); 3/8";P=1,5	cadena 50 cm (20"); 3/8";P=1,5
215	63 00 373	667/667SP		Vollmeißelkette 60 cm (24"); 3/8"; T=1,5; 84 Treibglieder, "Oregon Super Guard"	chain 60 cm (24"); 3/8";G=1,5	chaîne 60 cm (24"); 3/8";P=1,5	cadena 60 cm (24"); 3/8";P=1,5
215	63 00 373S	667/667SP		Vollmeißelkette 60 cm (24"); 3/8"; T=1,5; 84 Treibglieder, "SOLO"	chain 60 cm (24"); 3/8";G=1,5	chaîne 60 cm (24"); 3/8";P=1,5	cadena 60 cm (24"); 3/8";P=1,5
215	69 00 941	667/667SP		Vollmeißelkette 70 cm (28"); 3/8"; T=1,5; 92 Treibglieder, "Oregon Super Guard"	chain 70 cm (28"); 3/8";G=1,5	chaîne 70 cm (28"); 3/8";P=1,5	cadena 70 cm (28"); 3/8";P=1,5
215	69 00 941S	667/667SP		Vollmeißelkette 70 cm (28"); 3/8"; T=1,5; 92 Treibglieder, "SOLO"	chain 70 cm (28"); 3/8";G=1,5	chaîne 70 cm (28"); 3/8";P=1,5	cadena 70 cm (28"); 3/8";P=1,5
216	05 40 226			Linksschneider, "Oregon"	left cutter, "Oregon"	gouge gauche, "Oregon"	cortador izquierda, "Oregon"
216	05 40 272			Linksschneider, "SOLO"	left cutter, "SOLO"	gouge gauche, "SOLO"	cortador izquierda, "SOLO"
217	05 40 184			Verbindungsglied ohne Niet, "Oregon"	connection link without rivet, "Oregon"	maillon d'attache sans rivet, "Oregon"	eslabón de conexión sin remache, "Oregon"
217	05 40 254			Verbindungsglied ohne Niet, "SOLO"	connection link without rivet, "SOLO"	maillon d'attache sans rivet, "SOLO"	eslabón de conexión sin remache, "SOLO"
218	05 40 228			Treibglied "Oregon"	drive link, "Oregon"	maillon entraineur, "Oregon"	eslabón, "Oregon"
218	05 40 263			Treibglied "SOLO"	drive link, "SOLO"	maillon entraineur, "SOLO"	eslabón, "SOLO"
219	05 40 185			Verbindungsglied mit Niet, "Oregon"	connection link with rivet, "Oregon"	maillon d'attache avec rivet, "Oregon"	eslabón de conexión con remache, "Oregon"
219	05 40 255			Verbindungsglied mit Niet, "SOLO"	connection link with rivet, "SOLO"	maillon d'attache avec rivet, "SOLO"	eslabón de conexión con remache, "SOLO"
220	05 40 227			Rechtsschneider, "Oregon"	right cutter, "Oregon"	gouge droite, "Oregon"	cortador derecha, "Oregon"
220	05 40 278			Rechtsschneider, "SOLO"	right cutter, "SOLO"	gouge droite, "SOLO"	cortador derecha, "SOLO"
-	05 40 188			Niet, "Oregon"	rivet, "Oregon"	rivet, "Oregon"	remache, "Oregon"
-	05 40 277			Niet, "SOLO"	rivet, "SOLO"	rivet, "SOLO"	remache, "SOLO"
225	27 00 353		1	Öltank-Verschluß, kompl. (enth.:	oil-tank lid (incl.:	bouchon de réservoir d'huile (incl.:	tapa del deposito (incl.:
226	00 61 356		1	Verschlußdichtung 25x37x2,2)	fuel cap gasket)	joint)	joint)
230	23 00 626		1	Zündmodul PVL 105	ignition coil PVL 105	bobine, PVL 105	bobina, PVL 105
230	23 00 770 *+		1	Zündmodul, DUCATI	ignition coil DUCATI	bobine, DUCATI	bobina, DUCATI
231	00 73 385		1	Kontaktfeder	contact spring	resort de contact	resorte de contacto
232	00 84 600		1	Kerzenstecker	spark plug cap	capuchon bougie	terminal de bujía
233	00 64 292		1	Schlauch 6x1	hose	tuyau	tubo
234	00 84 564		1	Kurzschlußkabel	short circuit cable	câble interrupteur	cable interruptor
235	00 10 112		2	Zylinderschraube M5x22	screw	vis	tornillo
236	00 72 144		2	Spannscheibe 5 DIN 6796 A	tension washer	rondelle de tension	arandela elastica
240	60 74 502		1	Isolierkasten	insulating box	case isolante	caja aislante
241	60 63 293		1	Verschlußstück	sealing	joint	junta
245	00 11 267		4	Schraube M5x12 DIN 84	screw	vis	tornillo
246	00 10 266		2	Schraube M5x12 DIN 912	screw	vis	tornillo
247	60 31 277		4	Distanzstück 7,5/12x12	spacer	entretoise	tubo espaciador
248	63 00 169		4	Schwingmetall 27/19x20x5,1	rubber metal connexion	silentbloc	elemento amortiguador
249	60 74 391		1	Schutzdeckel 1	protection cover 1	protecteur 1	tapa proteccion 1
250	00 34 147		4	Federring 5 DIN 128	spring ring	rondelle élastique	anillo elástico
251	00 10 266		2	Zylinderschraube M5x12 DIN 912	screw	vis	tornillo
252	00 10 541		2	Zylinderschraube M5x20 DIN 912	screw	vis	tornillo

Bild-Nr. Pos.-No. Pos.-No.	Bestell-Nr. Order-No. No. de Cde. Ref.-Nr.	Modell Type Modèle Modelo	Menge Quantity Nombres Cantidad	Motor/ Gehäuse	Engine/ Housing	Moteur/ Carter	Motor/ Carter
253	60 43 285		1	Kettenfangblech	protection plate	tôle guide	chapa parador de cadena
254	60 74 393		1	Schutzdeckel 2	protection cover 2	protecteur 2	tapa proteccion 2
260	60 42 696		1	Anschlagkralle, außen	bucking spike	griffe	garra
261	60 42 695		1	Anschlagkralle, innen	bucking spike	griffe	garra
270	05 10 888		1	Dichtsatz - Vergaser HDA 158	gasket-kit - carburetor HDA 158	pochette de joints - carbureteur HDA 158	juego de juntas - carburador HDA 158
271	05 10 866		1	Reparatursatz - Vergaser HDA 158	repair-kit - carburetor HDA 158	kit de réparation - carbureteur HDA 158	juego de reparacion - carburador HDA 158
272	05 10 968		1	Drosselachsen-kit - Vergaser HDA 158	throttle axle kit - carburetor HDA 158	jeu d'axe - carbureteur HDA 158	juego de mariposa - carburador HDA 158
273	05 10 969		1	Chokeachsen-kit - Vergaser HDA 158	choke axle kit - carburetor HDA 158	jeu d'étrangleur - carbureteur HDA 158	juego eje choke - carburador HDA 158

*+: 662: 15451Ø
667 SP: 15001Ø

*++: 662: 15940Ø
667 SP: 15701Ø

662 / 667 SP

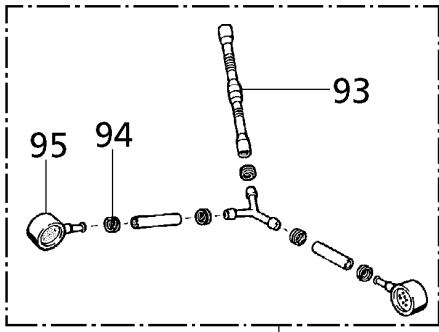

90

662: 15940Ø

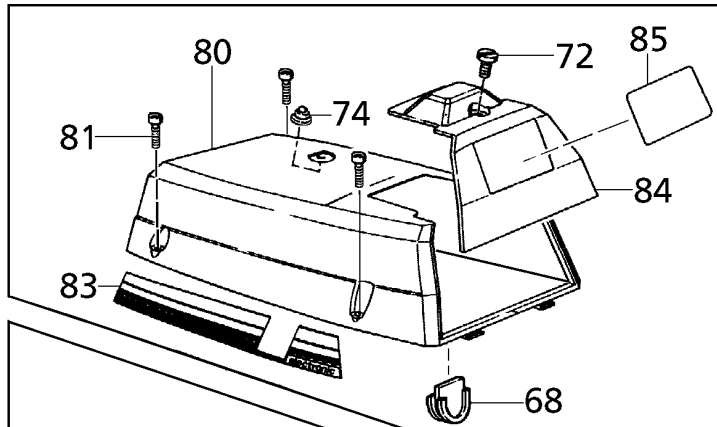

68

662: Ø 15939
667 SP: Ø 15700

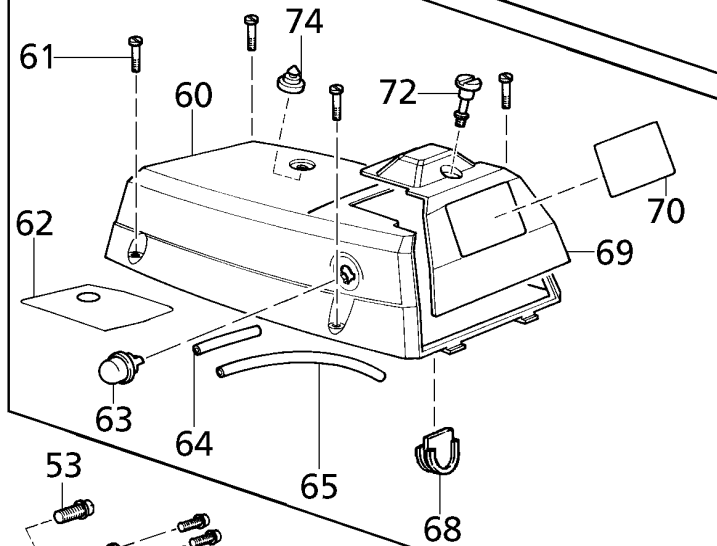

662: 15940Ø
667 SP: 15701Ø

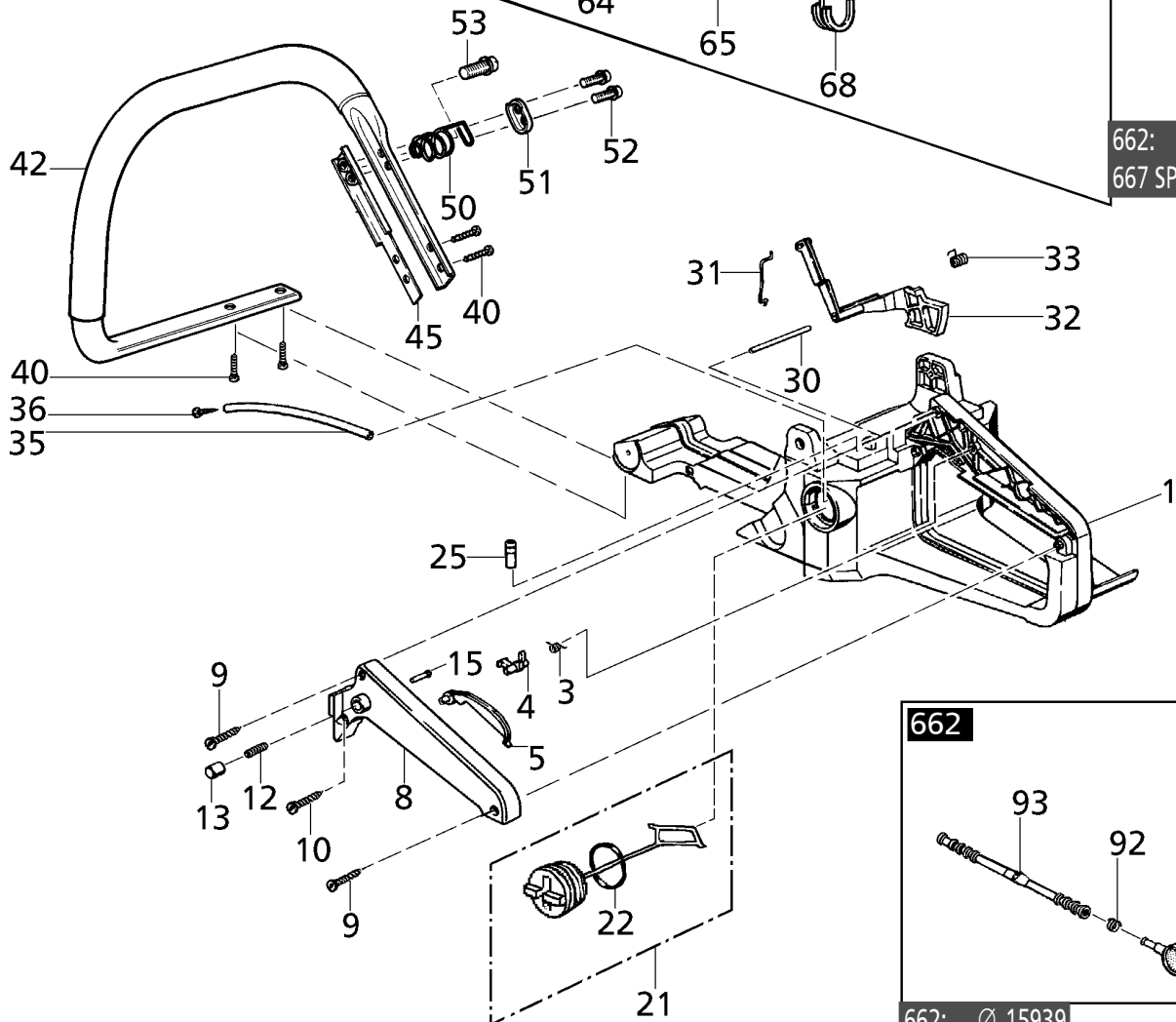

662

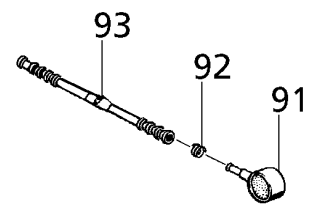

662: Ø 15939

662-b/04.98.tiff

Bild-Nr. Pos.-No. Pos.-No.	Bestell-Nr. Order-No. No. de Cde. Ref.-Nr.	Modell Type Modèle Modelo	Menge Quantity Nombres Cantidad	Bügel/Handgriff	Handle bar	Etrier	Asa
1	61 00 334		1	Hauptgehäuse, kompl.	main casing, kompl.	carter principal, compl.	carter, compl.
3	00 73 339		1	Drehfeder 0,7x7,7	spring	ressort	resorte
4	60 74 292		1	Blockierhebel	retainer lever	levier de blocage	palanca de bloquear
5	60 74 443		1	Sicherungshebel	safety lever	levier de sécurité	palanca seguro
8	60 73 480		1	Griffschale, links	grip plate, left	coquille poignée	pieza de la empunadura izq.
9	00 10 531		2	Zylinderschraube 4,2x19 DIN 7971	screw	vis	tornillo
10	00 18 355 +		1	Zylinderschraube 4x16	screw	vis	tornillo
12	00 70 147		1	Druckfeder 0,5x5,5x15	spring	ressort	resorte
13	60 74 381		1	Arretierrückler	lever	levier	bóton de sujecion
15	60 31 157		1	Arretierbolzen 3,8/5x20/22	retainer button	bouton de blocage	perno
21	27 00 353		1	Tankverschluß, kompl. (enth.:	tank lid, compl. (incl.:	bouchon de réservoir, compl. (incl.:	cierre deposito, compl. (incl.:
22	00 61 356		1	Verschlußdichtung)	gasket)	joint)	junta)
25	00 67 105		1	Impulsanschluß 3x14	impulse nipple	raccord d'impulsion	conexión impulso
30	20 31 227		1	Gashebelachse	throttle control axle	axe de gachette	eje de acelerador
31	20 36 370		1	Gasgestänge	throttle linkage	tringle, gaz	varillaje de gas
32	20 74 271		1	Gashebel	throttle lever	gachette, gaz	acelerador
33	00 73 356		1	Gashebelfeder 1x11	throttle control spring	ressort de gachette	resorte acelerador
35	00 64 300		1	Schlauch 3x1,5	hose	tuyau	tubo
36	00 10 446		1	Blechschrabe 3,5x19 DIN 7971	screw	vis	tornillo
40	00 18 274 +		4	Linsenschraube 5x16	screw	vis	tornillo
42	68 00 224		1	Haltebügel, kompl.	handle bar, compl.	étrier, compl.	asa, compl.
45	63 00 212		1	Verstärkungsblech	reinforcing plate	tôle de renfort	chapa de refuerzo
50	00 73 396		1	Dämpfungsfeder 3x19x26	spring	ressort	resorte
51	60 43 107		1	Flanschblech	flange plate	tôle bride	chapa
52	00 18 335		2	Zylinderschraube M5x12	screw	vis	tornillo
53	00 18 346		1	Zylinderschraube M6x16	screw	vis	tornillo
60	61 00 401 +*		1	Haube	cover	couvercle	cubierta
61	00 10 177 +*		4	Zylinderschraube M5x16 DIN 84	screw	vis	tornillo
62	60 42 714 +*		1	Isolierfolie	insulating foil	feuille d'isolement	laminilla
63	27 00 322 +*		1	Primer	primer	primer	cabador
64	00 64 407 +*		1	Schlauch 2x1,5	fuel hose	tuyau	tubo
65	00 64 430 +*		1	Schlauch 3x1,5	fuel hose	tuyau	tubo
68	20 74 309		1	Verschlußstopfen	plug	bouchon	tapón
69	60 73 486 +*		1	Haubendeckel	cover lid	couvercle capot	tapa de cubierta
70	60 49 295 +*	662	1	Typenschild "662"	decal	autocollant	etiqueta
70	60 49 296 +*	667	1	Typenschild "667"	decal	autocollant	etiqueta
70	60 49 398 +*	667 SP	1	Typenschild "667 SP"	decal	autocollant	etiqueta
72	00 11 283		1	Schraube M5x37,5	screw	vis	tornillo
74	00 94 252		1	Distanzgummi	rubber	cale caoutchouc	goma de distancia
80	61 00 318	662	1	Haube	cover	capot	tapa
80	61 00 320	667/667 SP	1	Haube	cover	capot	tapa
81	00 11 258		4	Zylinderschraube M5x17	screw	vis	tornillo
83	00 69 649		1	Klebeschild	decal	autocollant	etiqueta
84	60 73 486	662	1	Haubendeckel	cover lid	couvercle capot	tapa de cubierta
84	60 73 495	667/667 SP	1	Haubendeckel	cover lid	couvercle capot	tapa de cubierta
85	00 69 605	662	1	Klebeschild	decal	autocollant	etiqueta
85	00 69 607	667	1	Klebeschild	decal	autocollant	etiqueta
90	27 00 337		1	Benzinsucher, kompl.	fuel pick-up, compl.	crépine d'essence	busador
91	27 00 327	662	1	Benzinsucher	fuel pick-up	crépine d'essence	busador
92	00 73 351	662	1	Schlauchöse 6,7x0,9x2	grommet	collier	manguito de cable
93	60 63 328		1	Kraftstoffschlauch 3x149	fuel hose	tuyau à essence	tubo gasolina
94	00 73 352		5	Schlauchöse, 8x0,7x3	grommet	collier	ojete
95	27 00 327		2	Benzinsucher	fuel pick-up	crépine d'essence	busador

*+: 662: 15940Ø
667 SP: 15701Ø

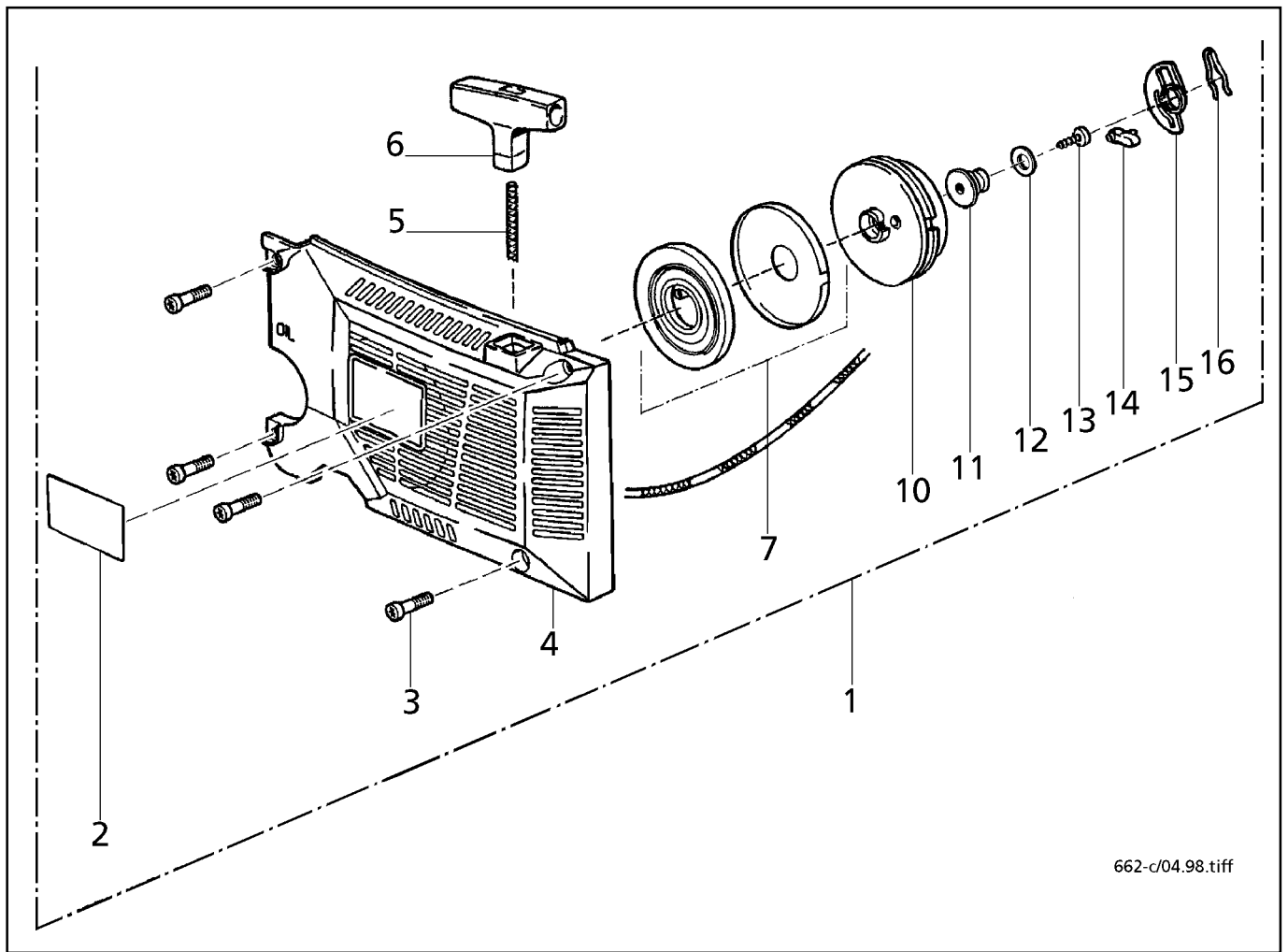

662-c/04.98.tiff

Bild-Nr. Pos.-No. Pos.-No. Pos.-No.	Bestell-Nr. Order-No. No. de Cde. Ref.-Nr.	Modell Type Modèle Modelo	Menge Quantity Nombres Cantidad	Starter	Starter	Lanceur	Arranque
1	26 00 278		1	Starter, kompl.	starter, compl.	lanceur, compl.	arranque
2	00 69 889		1	Klebeschild "SOLO"	decal	autocollant	etiqueta
3	00 10 177 +		4	Zylinderschraube M5x16 DIN 84 A	screw	vis	tornillo
4	21 00 558		1	Startergehäuse	starter housing	carter lanceur	caja de arranque
5	00 63 152		1	Starterseil	starter rope	corde	cuerda de arranque
6	20 74 365		1	Startergriff	starter grip	poignée	empunadura de arranque
7	26 00 283		1	Federkassette	spring cassette	cassette de ressort	caja de resorte
10	20 74 993		1	Seilrolle	starter pulley	poulie	roldana
11	20 31 995		1	Distanzstück 16x4,3x5,7	spacer	pièce d'écartement	espaciador
11	20 31 965 +		1	Distanzstück 4,3x12,5x5	spacer	pièce d'écartement	espaciador
12	00 31 611 +		1	Scheibe 4,3x16x1	washer	rondelle	arandela
13	00 18 384		1	Linsenschraube 4x16	screw	vis	tornillo
14	20 74 209		1	Starterklinke	pawl	cliquet lanceur	trinquete
15	20 74 408		1	Kulisse	template	coulisse	colisa
16	00 73 365		1	Federstecker 1,4	pin	goupille beta	clavija elastica

Bestell-Nr. Order-No. No. de Cde. Ref.-Nr.	Menge Quantity Nombres Cantidad	Seite page page pagina	Bestell-Nr. Order-No. No. de Cde. Ref.-Nr.	Menge Quantity Nombres Cantidad	Seite page page pagina	Bestell-Nr. Order-No. No. de Cde. Ref.-Nr.	Menge Quantity Nombres Cantidad	Seite page page pagina	Bestell-Nr. Order-No. No. de Cde. Ref.-Nr.	Menge Quantity Nombres Cantidad	Seite page page pagina
00 10 112	2	6	00 50 202	2	4	05 10 969	1	7	27 00 327	2	9
00 10 134	4	4	00 52 143	1	4	05 40 184		6	27 00 337	1	9
00 10 145	4	5	00 52 148	1	5	05 40 185		6	27 00 353	1	6
00 10 157	4	5	00 54 247	2	4	05 40 188		6	27 00 353	1	9
00 10 177	1	4	00 55 103	1	4	05 40 226		6	27 00 382	1	4
00 10 177 *+	4	9	00 55 171	1	4	05 40 227		6	30 32 638	1	4
00 10 177 +	4	10	00 55 266	2	5	05 40 228		6	30 38 399	1	4
00 10 260	1	4	00 61 223	1	4	05 40 254		6	34 00 204	1	4
00 10 266	2	6	00 61 342	1	5	05 40 255		6	35 00 359	1	4
00 10 266	2	6	00 61 356	1	6	05 40 263		6	35 00 365	1	4
00 10 360	2	5	00 61 356	1	9	05 40 272		6	60 31 157	1	9
00 10 446	1	9	00 62 110	1	4	05 40 277		6	60 31 189		4
00 10 478	1	5	00 62 237	1	4	05 40 278		6	60 31 189	1	4
00 10 531	2	9	00 62 246	1	5	20 31 227	1	9	60 31 222 *+	1	4
00 10 541	2	6	00 62 253	1	4	20 31 233	1	5	60 31 229	1	4
00 10 559	2	6	00 62 284		4	20 31 965 +	1	10	60 31 277	4	6
00 10 567	2	5	00 62 284	1	4	20 31 995	1	10	60 32 594	1	5
00 11 258	4	9	00 63 152	1	10	20 36 370	1	9	60 32 670	1	5
00 11 267	3	4	00 64 292	1	6	20 36 373	1	4	60 42 695	1	7
00 11 267	4	4	00 64 300	1	9	20 43 342	1	5	60 42 696	1	7
00 11 267	1	6	00 64 407 *+	1	9	20 48 324	2	5	60 42 714 *+	1	9
00 11 267	4	6	00 64 430 *+	1	9	20 48 326	2	5	60 42 724	1	5
00 11 282	2	5	00 66 197	1	4	20 61 428	1	4	60 42 768	1	6
00 11 283	1	9	00 66 197	1	5	20 61 430	1	5	60 43 107	1	9
00 13 243	1	5	00 66 440	1	4	20 61 431	1	5	60 43 285	1	7
00 15 279	2	5	00 67 105	1	9	20 61 432	1	5	60 43 311	1	5
00 18 231	2	4	00 69 553	1	4	20 74 209	1	10	60 49 295 *+	1	9
00 18 231	1	5	00 69 605		4	20 74 271	1	9	60 49 296 *+	1	9
00 18 256	2	5	00 69 605	1	9	20 74 309	1	9	60 49 398 *+	1	9
00 18 261	1	4	00 69 607	1	9	20 74 365	1	10	60 63 293	1	6
00 18 274 +	4	9	00 69 649	1	9	20 74 377	1	4	60 63 328	1	9
00 18 335	2	9	00 69 889	1	10	20 74 390	1	5	60 63 329	1	4
00 18 336	2	5	00 70 147	1	9	20 74 408	1	10	60 71 248	1	6
00 18 346	2	5	00 70 253	1	5	20 74 946 *+	1	5	60 73 445	1	5
00 18 346	1	9	00 70 254	1	5	20 74 993	1	10	60 73 480	1	9
00 18 355 +	1	9	00 70 257		4	21 00 470	1	4	60 73 486	1	9
00 18 384	1	10	00 70 257	1	4	21 00 558	1	10	60 73 486 *+	1	9
00 20 145	1	4	00 71 215		4	22 00 871	1	4	60 73 489	1	4
00 20 214	2	5	00 71 215	1	5	22 00 883	1	5	60 73 495	1	9
00 21 232	1	4	00 72 140	3	4	22 00 884	1	5	60 74 253	1	4
00 28 118	1	5	00 72 140	1	5	22 00 952	1	5	60 74 254 *++	1	4
00 28 137	1	5	00 72 144	2	6	22 00 954	1	5	60 74 281	2	4
00 30 108	1	4	00 72 145	1	4	22 00 984	1	5	60 74 281	2	5
00 30 115	1	5	00 73 339	1	9	22 00 991	1	5	60 74 292	1	9
00 31 276	1	4	00 73 351	1	9	23 00 469	1	4	60 74 363	1	4
00 31 512	1	4	00 73 352	5	9	23 00 626	1	6	60 74 381	1	9
00 31 515		4	00 73 356	1	9	23 00 658	1	5	60 74 389	1	4
00 31 515	2	4	00 73 365	1	10	23 00 714	1	5	60 74 391	1	6
00 31 526	1	4	00 73 385	1	6	23 00 730	1	5	60 74 393	1	7
00 31 611 +	1	10	00 73 391	1	5	23 00 770 *+	1	6	60 74 394	1	5
00 33 311	1	5	00 73 396	1	9	23 00 780 *++	1	5	60 74 396	1	4
00 34 147	4	4	00 75 101	1	5	24 00 265	1	4	60 74 401	1	4
00 34 147	1	4	00 84 564	1	6	24 00 301 *+	1	4	60 74 443	1	9
00 34 147	3	6	00 84 600	1	6	25 00 541	1	4	60 74 452		4
00 34 147	4	6	00 94 252	1	9	25 00 611	1	5	60 74 452	1	4
00 34 201	4	5	00 94 256	1	5	25 00 620	1	5	60 74 502	1	6
00 34 201	1	5	00 94 294	3	4	26 00 278	1	10	61 00 305	1	5
00 34 201	2	5	05 10 866	1	7	26 00 283	1	10	61 00 316	1	5
00 34 202	4	5	05 10 888	1	7	27 00 322 *+	1	9	61 00 318	1	9
00 40 102	1	5	05 10 968	1	7	27 00 327	1	9	61 00 320	1	9

Bestell-Nr. Order-No. No. de Cde. Ref.-Nr.	Menge Quantity Nombres Cantidad	Seite page page pagina	Bestell-Nr. Order-No. No. de Cde. Ref.-Nr.	Menge Quantity Nombres Cantidad	Seite page page pagina	Bestell-Nr. Order-No. No. de Cde. Ref.-Nr.	Menge Quantity Nombres Cantidad	Seite page page pagina	Bestell-Nr. Order-No. No. de Cde. Ref.-Nr.	Menge Quantity Nombres Cantidad	Seite page page pagina
61 00 334	1	9									
61 00 401 *+	1	9									
62 00 129	1	5									
63 00 169	4	6									
63 00 174	1	5									
63 00 175	1	5									
63 00 212	1	9									
63 00 373		6									
63 00 373S		6									
64 00 179	1	4									
64 00 210	1	4									
64 00 211		4									
64 00 211	1	4									
67 00 124	1	4									
68 00 224	1	9									
69 00 368		5									
69 00 369		6									
69 00 369S		6									
69 00 370		6									
69 00 371		6									
69 00 371S		6									
69 00 372		6									
69 00 498		5									
69 00 499		6									
69 00 499S		6									
69 00 937		6									
69 00 941		6									
69 00 941S		6									

Allgemeine Richtlinien für die Bestellung von Original SOLO Ersatzteilen:

Voraussetzung für eine reibungslose Erledigung sind folgende Angaben:

1. Ersatzteil-Bestellnummer
2. Gewünschte Anzahl
3. Typenbezeichnung des Geräts

Diese Ersatzteilliste ist für die Lieferung und Ausstattung von SOLO Erzeugnissen unverbindlich.

Im Interesse der technischen Weiterentwicklung bleiben Konstruktionsänderungen vorbehalten.

General Directions for Ordering Original SOLO Spare Parts:

Spare parts orders are to be placed with the SOLO Sales Branch or SOLO Distributor: For correct and diligent processing of your order, please give the following information:

1. Spare Part number
2. Quantity
3. Model and serial number
4. Shipping instructions

Delivery is made in accordance with our general sales and delivery conditions. This spare parts list is non-committal for us with regard to delivery and layout of SOLO products. In favour of technical improvements, design modifications are subject to change without notice.

Directives générales pour les commandes de pièces de rechange d'origine SOLO:

Il est indispensable de préciser dans toutes les commandes de pièces:

1. - le numéro de référence de la pièce
2. - la quantité
3. - le type de la machine
4. - le mode d'expédition

Les livraisons sont effectuées dans le cadre de nos conditions générales de vente. Toutes modifications réservées.

Directivas Generales de pedido de la firma SOLO:

Por adelantado de un arreglo sin dificultades necesitamos siguientes indicaciones:

1. Número de repuesto
2. Numero de cantidad
3. Modelo y número de serial
4. Instrucción de Envío

Este lista de repuestos no es obligatoria para los envíos y/o forma de equipo de los productos SOLO.

En el interés del constante desarrollo debemos reservarnos el derecho de cambios.