

solo[®]

Ersatzteilliste

Spare parts list

Liste de pièces de rechange

Lista de piezas de recambio

Motorsägen

Chain saws

Tronçonneuses

Motosierras

630 / 640

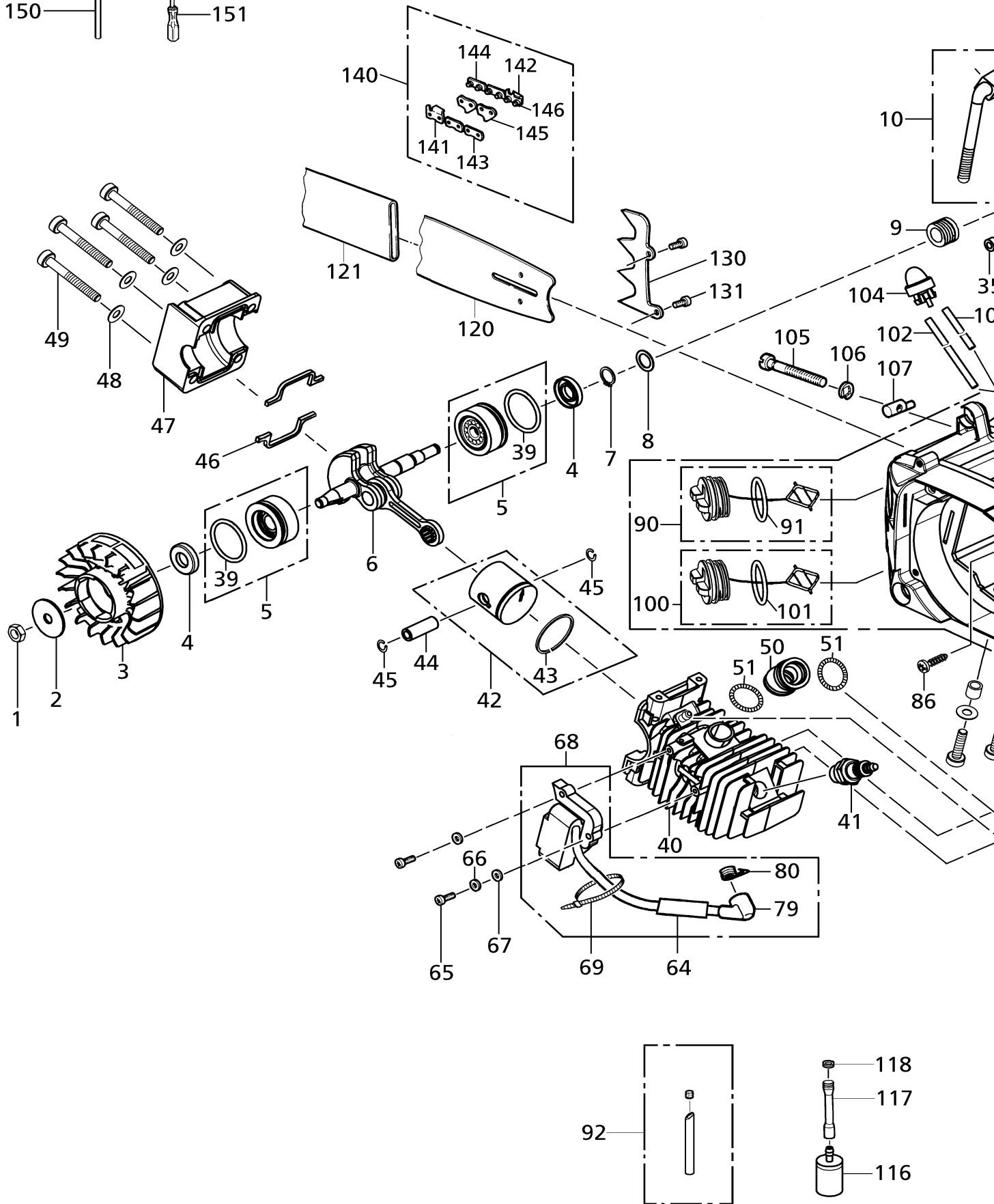
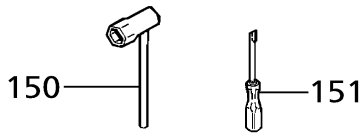

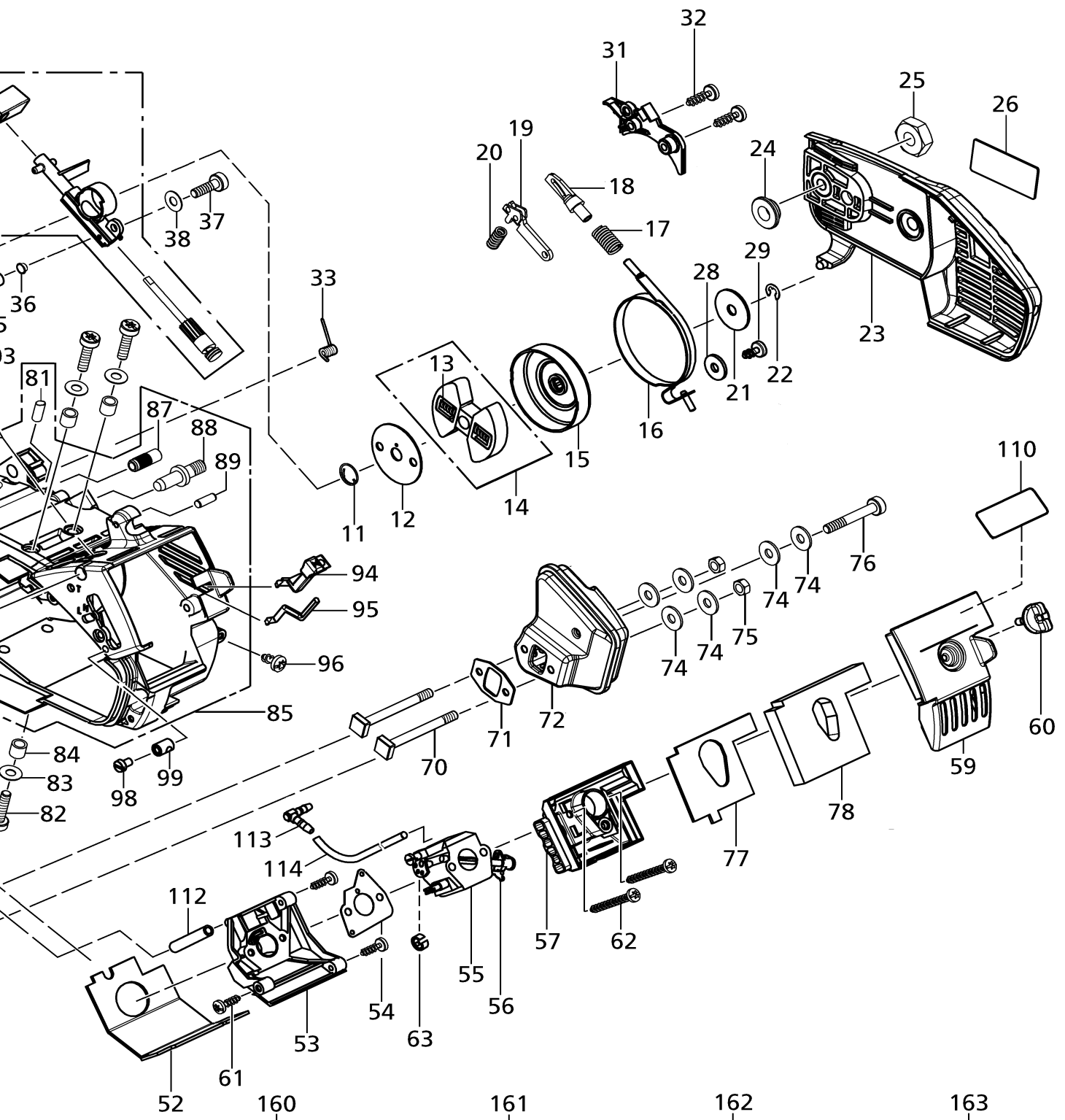

160

Dichtsatz - Vergaser
Gasket - kit - Carburetor
Pochette de joints - Carburateur
Juego de juntas - Carburador

161

Reparatursatz - Vergaser
Repair - kit - Carburetor
Kit de réparation - Carburateur
Juego de reparación - Carburador

162

Drosselachsen-kit - Vergaser
Throttle axle kit - Carburetor
Jeu d'axe - Carburateur
Juego de mariposa - Carburador

163

Chokeachsen-kit - Vergaser
Choke axle kit - Carburetor
Jeu d'étrangleur - Carburateur
Juego eje choke - Carburador

Bild-Nr. Pos.-No. Pos.-No. Pos.-No.	Bestell-Nr. Order-No. No. de Cde. Ref.-Nr.	Modell Type Modelo Modelo	Menge Quantity Nombres Cantidad	Motor	Engine	Moteur	Motor
1	00 20 145		1	Sechskantmutter M8x1 DIN 934	nut	écrou	tuerca
2	00 72 141		1	Scheibe 9,2x18x0,7 DIN 2093 B	washer	rondelle	arandela
3	24 00 278		1	Lüfterrad	fan wheel	volant magnétique	turbina
4	00 54 237		2	Wellendichtring 12x25x5	oil seal	joint spy	reten
5	21 00 364		2	Lagerhülse 12x38,17x17	sleeve	douille	casquillo
6	22 00 113		1	Kurbelwelle	crankshaft	vilebrequin	cigüenal
7	00 55 134		1	Sicherungsring 12x1 DIN 471	circlip	circlip	anillo de seguridad
8	00 31 194		1	Paßscheibe 12x18x0,5 DIN 988	washer	rondelle	arandela
9	60 74 117		1	Mitnehmerschnecke	activator	entraîneur à vis	activador
10	06 10 533		1	Ölpumpe Set	oil-pump set	kit pompe à huile	bomba de aceite
11	00 73 220		1	Feder 1x16	spring	ressort	resorte
12	60 42 630		1	Scheibe 10x48x1	washer	rondelle	arandela
13	00 71 226		2	Druckfeder 1,7x6,2x17,5	pressure spring	ressort de pression	resorte
14	35 00 429		1	Fliehkraftkupplung M10x1	centrifugal clutch	embrayage centrifuge	embrague centrifugal
15	35 00 196		1	Kupplungsglocke 3/8" 6Z12/46,5	clutch drum	cloche d'embrayage	campana embrague
16	62 00 134		1	Bremsband	brake band	ruban de frein	cinta de freno
17	00 70 305		1	Druckfeder 1,3x10,2x56	pressure spring	ressort de pression	resorte
18	63 00 208		1	Verstellung	brake linkage	poussoir ressort frein	varilla
19	63 00 175		1	Druckblech	pressure plate	tôle de pression	chapa de presión
20	00 70 253		1	Druckfeder 1,5x7x21,5	pressure spring	ressort de pression	resorte
21	00 31 333		1	Scheibe 8,1x32x1,5	washer	rondelle	arandela
22	00 55 216		1	Sicherungsscheibe 6 DIN 6799	safety washer	circlip	seguro
23	61 00 412		1	Schwertabdeckung	chain guard	carter de chaîne	cubierta espada
24	60 31 993		1	Distanzbuchse 8,5x18,6/14,5x5,8	distance sleeve	entretoise	casquillo
25	00 20 214		1	Sechskantmutter M8	nut	écrou	tuerca
26	00 69 106		1	SKS „SOLO“	decal „SOLO“	autocollant „SOLO“	adhesivo „SOLO“
28	00 30 102		1	Scheibe 5,3 DIN 125 B	washer	rondelle	arandela
29	00 18 362		1	Linsenschraube 5x10	screw	vis	tornillo
31	60 74 975		1	Bremsbandabdeckung	brake band cover	recouvrement frein de chaîne	cubierta cinta de freno
32	00 18 274		2	Linsenschraube 5x16	screw	vis	tornillo
33	00 73 381		1	Drehfeder 1,3x7,1	torsion spring	ressort de torsion	resorte
35	60 74 120		1	Distanzhülse	spacer sleeve	entretoise	espaciador
36	00 44 130		1	Hohl Niet	rivet	rivet	remache
37	00 18 336		1	Zylinderschraube M5x16	screw	vis	tornillo
38	00 30 108		1	Scheibe 5,3 125 B	washer	rondelle	arandela
39	00 62 280		2	O-Ring	o-ring	joint torique	anillo
40	22 00 989	630	1	Nikasilzylinder Ø 38,00 mm	cylinder	cyindre	cilindro
	22 00 987	640	1	Nikasilzylinder Ø 40,00 mm	cylinder	cyindre	cilindro
41	23 00 730		1	Zündkerze WSR6F200	spark plug	bougie	bujia
42	22 00 633	630	1	Kolben Ø 38,00 mm (enth.Pos.43)	piston	piston	piston
	22 00 630	640	1	Kolben Ø 40,00 mm (enth.Pos.43)	piston	piston	piston
43	20 48 386	630	1	Kolbenring 38x1,5	piston ring	segment	anillo de piston
	20 48 140	640	1	Kolbenring 40x1,5	piston ring	segment	anillo de piston
44	20 31 249 25		1	Kolbenbolzen 10/6x28	piston pin	axe de piston	bulon de piston
45	00 55 267		2	Sicherungsring 10x0,8 DIN 73130	piston pin circlip	clip d'axe piston	anillo de seguridad
46	20 63 370		2	Dichtungsteil Kurbelgehäuse			
47	61 00 134		1	Kurbelgehäuse kompl.	crankcase, compl.	carter moteur, compl.	carter cigüenal, compl.
48	00 72 140		4	Tellerscheibe 5,2x12x0,5 DIN 2093 A	spring washer	rondelle	muelle de disco
49	00 18 340		4	Zylinderschraube M5x40	screw	vis	tornillo
50	60 63 101		1	Verbindungsschlauch	hose connection	tuyau raccord	tubo
51	00 71 153		2	Ringfeder	spring ring	ressort bague	resorte
52	00 60 120		1	Isolierplatte	insulating plate	plaque isolatrice	chapa
53	23 00 815		1	Vergaserstutzen mit Kugel	manifold	bride de carburateur	brida carburador
54	20 61 514		1	Vergaserstutzendichtung 0,5mm dick	manifold gasket	joint bride carburateur	junta de brida
55	23 00 812		1	Vergaser BING 47A102B	carburetor	carburateur	carburador
55	23 00 138		1	Vergaser WALBRO WT-577	Carburetor	carburateur	carburador
56	60 74 940		1	Rasthebel	stop lever	levier d'arret	palanca de engaste
57	25 00 209		1	Filtergehäuse	filter housing	carter filtre	carter de filtro
59	60 74 116		1	Deckel	cover	couvercle	cubierta
60	68 00 334		1	Filterschraube M5x16	screw	vis	tornillo
61	00 18 274		3	Linsenschraube 5x16	screw	vis	tornillo
62	00 18 226		2	Linsenschraube 5x40	screw	vis	tornillo
63	20 74 905		1	Haltering	retaining ring	bague de support	anillo soporte
64	00 61 130		1	Klebefilz	felt	feutre	fieltro
65	00 18 327		2	Zylinderschraube M4x20	screw	vis	tornillo
66	00 30 101		1	Scheibe 4,3 DIN 433	washer	rondelle	arandela
67	00 72 148		2	Sicherungsscheibe 4 DIN 6796 A	washer	rondelle	disco de tension
68	23 00 481		1	Zündspule Selettra	ignition coil	bobine allumage	bobina
69	00 66 455		1	Kabelband	cabel band	serre cable	cinta de cable
70	00 18 110		2	Vierkantschraube M5x50	screw	vis	tornillo
71	20 61 516		1	Auspuffdichtung	muffler gasket	joint amortisseur	junta del escape
72	25 00 196		1	Auspuff	exhaust	échappement	escape
74	00 72 144		6	Sicherungsscheibe 5 DIN 6796 A	tension washer	rondelle de tension	arandela elastica

Bild-Nr. Pos.-No. Pos.-No. Pos.-No.	Bestell-Nr. Order-No. No. de Cde. Ref.-Nr.	Modell Type Modèle Modelo	Menge Quantity Nombres Cantidad	Motor	Engine	Moteur	Motor
75	00 28 137		2	Sechskantmutter M5 DIN 980	nut	contre-écrou	tuerca
76	00 18 399		1	Zylinderschraube M5x35	screw	vis	tornillo
77	20 48 390		1	Filterplatte	filter plate	plaque filtre	chapa filtro
78	20 48 389		1	Filter Schaumplatte	filter foam plate	plaque filtre	chapa filtro
79	00 84 621		1	Kerzenstecker	spark plug cap	capuchon de bougie	tapa de bujia
80	00 73 360		1	Kontaktfeder	contact spring	ressort de contact	resorte de contacto
81	27 00 403		1	Rückschlagventil	check valve	soupape de antiretour	valvula
82	00 18 423		4	Zylinderschraube M5x18	screw	vis	tornillo
83	00 72 140		4	Tellerscheibe 5,2x12x0,5 DIN 2093 A	spring washer	rondelle	muelle de disco
84	00 33 268 25		4	Distanzrohr 8x1,2x7,5	spacer	entretoise	pieza distanciadora
85	61 00 136		1	Hauptgehäuse kompl.	main housing, compl.	carter principal, compl.	carter principal, compl.
86	00 18 363		1	Linsenschraube 5x20	screw	vis	tornillo
(87)	00 41104		1	Schwertführungsbolzen	bolt	boulon	perno
(88)	00 18 380		1	Schwertstiftschraube M8x19/41	screw	vis	tornillo
(89)	00 40 188		1	Zylinderstift 5H 8x14	pin	goupille	perno
90	27 00 410		1	Tankverschluß, Benzin, enth. (tank cap	bouchon réservoir	tapa de deposito
(91)	00 62 332		1	O-Ring 23,39x3,53)	o-ring	joint torique	anillo
92	25 00 103		1	Entlüftungsschlauch kompl.	hose	tuyau	tubo
94	60 74 136		1	Chokehebel	choke lever	jeu levier	palanca choke
95	60 74 137		1	Stift Halbgas	pin	levier mi-gaz	perno
96	00 18 36		1	Linsenschraube 5x10	screw	vis	tornillo
98	00 10 231		1	Zylinderschraube M4x6	screw	vis	tornillo
99	60 32 130		1	Klemmbuchse	bushing	douille de serrage	cojinete
100	27 00 345		1	Tankverschluß, Öl. enth. (oil tank cap	bouchon réservoir	tapa de deposito
(101)	00 62 288		1	O-Ring 25,2x3)	o-ring	joint torique	anillo
102	00 64 407		1	Schlauch 2x1,5x240	tube	durite	manguera
103	00 64 441		1	Schlauch 3x1,5x200	tube	durite	manguera
104	27 00 322		1	Primer	primer	primer	cabador
105	00 18 420		1	Spannschraube	p.h. screw	vis t.c.	tornillo
106	00 55 101		1	Sicherungsscheibe 4 DIN 6799	tension washer	rondelle de tension	arandela elastica
107	60 32 640		1	Kettenspannbolzen	chain tension bolt	tendeur de chaîne	perno de fijacion de cad.
110	00 69 347	630	1	SKS „SOLO 630“	decal „SOLO 630“	autocollant „SOLO 630“	adhesivo „SOLO 630“
110	00 69 348	640	1	SKS „SOLO 640“	decal „SOLO 640“	autocollant „SOLO 640“	adhesivo „SOLO 640“
112	00 64 319		1	Schlauch 5x1,5x45	hose	tuyau	tubo
113	00 66 381		1	Winkelstutzen	elbow	raccord coude	racor
114	00 64 300		1	Schlauch 3x1,5x195	tube	durite	manguera
116	27 00 416		1	Filter Benzinsucher	fuel pick-up	crépine d'essence	filtro gasolina
117	20 63 212		1	Kraftstoffschlauch 3x107	tube	durite	manguera
118	00 73 352		1	Schlauchöse 8x0,7x3	tube eye	œillet	ojete
120	69 00 744	630	1	Schwert 35 cm (14"); 1,3	guide bar	guide chaîne	espada
120	69 00 900	640	1	Schwert 40 cm (16"); 1,3	guide bar	guide chaîne	espada
121	60 71 245		1	Kettenschutz	chainguard	protect. chaîne	protect. cadena
130	60 43 323		1	Anschlagkralle	bucking spike	griffe de butée	garra de apoyo
131	00 18 362		2	Linsenschraube 5x10	screw	vis	tornillo
140	69 00 136	630	1	Kette 3/8" S; 1,3; 52 E; 14"; für 35 cm	chain	chaîne	cadena
140	69 00 600	640	1	Kette 3/8" S; 1,3; 57 E; 16"; für 40 cm	chain	chaîne	cadena
141	05 40 197		1	Linksschneider	left cutter	couteau gauche	cortador izquierda
142	05 40 198		1	Rechtsschneider	right cutter	couteau droite	cortador derecha
143	05 40 199		1	Verbindungsglied ohne Niet	connect. link w/o rivet	maillon sans rivet	eslabon
144	05 40 200		1	Verbindungsglied mit Niet	connect. link with rivet	maillon avec rivet	eslabon
145	05 40 201		1	Treibglied	drive link	maillon entraineur	eslabon
146	05 40 202		1	Niet	rivet	rivet	remache
147	05 40 991		1	Sicherheitsverbindungsglied	connecting link	maillon de securite	diente
150	00 80 343		1	Kombischlüssel 19	combi wrench	clef universelle	llave
151	00 80 494		1	Schraubendreher 3	screw-driver	tournevis	destornillador
160	05 10 992		1	Dichtsatz Vergaser BING 47A102B	gasket-kit - carburetor	pochette - carburateur	juego de juntas - carburador
161	05 10 931		1	Reparatursatz Vergaser BING 47A102B	repair-kit - carburetor	kit de réparation carburateur	juego de rep. - carburador
162	05 10 932		1	Drosselachsenkit Vergaser BING 47A102B	throttle axle kit - carburetor	kit axe clapet gaz carburateur	juego de eje - carburador
163	05 10 305		1	Chokeachsenkit Vergaser BING 47A102B	choke axle kit - carburetor	kit axe de choke	juego eje choke - carburador
160	05 10 985		1	Dichtsatz Vergaser WALBRO WT-577	gasket-kit - carburetor	pochette - carburateur	juego de juntas - carburador
161	05 10 984		1	Reparatursatz Vergaser WALBRO WT-577	repair-kit - carburetor	kit de réparation carburateur	juego de rep. - carburador
162	05 10 986		1	Drosselachsenkit Vergaser WALBRO WT-577	throttle axle kit - carburetor	kit axe clapet gaz carburateur	juego de eje - carburador
163	05 10 987		1	Chokeachsenkit Vergaser WALBRO WT-577	choke axle kit - carburetor	kit axe de choke	juego eje choke - carburador



Bild-Nr. Pos.-No. Pos.-No.	Bestell-Nr. Order-No. No. de Cde. Ref.-Nr.	Modell Type Modèle Modelo	Menge Quantity Nombres Cantidad	Bügel/Handgriff	Handle bar	Etrier	Asa
2	00 18 358		1	Linsenschraube 4x35	screw	vis	tornillo
3	00 18 356		3	Linsenschraube 4x20	screw	vis	tornillo
4	60 73 102		1	Griffschale links	grip cup left	cosse de poignée g.	casca izqu.
5	60 73 103		1	Griffschale rechts	grip cup right	cosse de poignée dr.	casca der.
6	00 73 130		1	Schenkelfeder	spring	ressort	resorte
7	60 74 118		1	Gashebel	gas lever	levier des gaz	palanca de gas amarillo
8	00 35 160		1	Sicherungsscheibe 7x13,5x1,4	washer	rondelle	arandela de seguridad
9	60 74 968		1	Sicherungshebel	safety lever	levier de sécurité	palanca seguridad
10	28 00 101		1	Bowdenzug	throttle cable	câble bowden	cable de bowden
11	60 43 630		1	Befestigungsblech	fixing plate	tôle fixation	chapa de fijacion
12	00 18 354		1	Linsenschraube 4x12	screw	vis	tornillo
13	00 18 361		4	Linsenschraube 5x12	screw	vis	tornillo
14	00 73 397		4	Dämpfungsfeder 2,5x13,5x33	av spring	ressort amortisseur	resorte
15	00 84 868		1	Kabel; Masse+Kurzschluß	cable; ground+short circuit	câbles court-circuit	cable; masa +cortocircuito

Bild-Nr. Pos.-No. Pos.-No. Pos.-No.	Bestell-Nr. Order-No. No. de Cde. Ref.-Nr.	Modell Type Modèle Modelo	Menge Quantity Nombres Cantidad	Bügel/Handgriff	Handle bar	Etrier	Asa
16	00 84 477		1	Kurzschlußschalter	short circuit switch	interrupteur	interruptor
17	60 73 104		1	Haltebügel	handle	étrier	estribo
18	00 18 274		2	Linsenschraube 5x16	screw	vis	tornillo
19	68 00 348		1	Griffschale links kompl., enth.(grip cup left cpl.(cosse de poignée g.cpl.(casaca izqu. cpl (
(4)	60 73 102		1	Griffschale links	grip cup left	cosse de poignée g.	casaca izqu.
(6)	00 73 130		1	Schenkelfeder	spring	ressort	resorte
(7)	60 74 118		1	Gashebel	throttle lever	levier des gaz	palanca de gas
(8)	00 35 160		1	Sicherungsscheibe 7x13,5x1,4	washer	rondelle	arandela
(10)	28 00 101		1	Bowdenzug	throttle cable	câble bowden	cable de bowden
(11)	60 43 630		1	Befestigungsblech	fixing plate	tôle fixation	chapa de fijacion
(12)	00 18 354		1	Linsenschraube 4x12)	screw)	vis)	tornillo)
20	00 18 361		3	Linsenschraube 5x12	screw	vis	tornillo
21	60 74 130		4	Hülse	sleeve	douille	casquillo
22	00 18 276		1	Linsenschraube 5x35	screw	vis	tornillo
23	50 74 159		2	Kappe	cap	bouchon	caperuza
25	00 18 363		1	Linsenschraube 5x20	screw	vis	tornillo
26	00 30 108		1	Scheibe 5,3	washer	rondelle	arandela
27	00 33 231		1	Distanzrohr 10x2,3x9	spacer tube	entretoise	tubo distanciador
28	60 73 105		1	Handschutz	hand protection	protection main	proteccion de mano
29	60 32 690		1	6-kt.-Schraube M4x21,5	screw	vis	tornillo
30	00 28 118		1	6-kt. Mutter M4	nut	écrou	tuerca
31	00 33 230		1	Distanzrohr 10x2,3x15,5	spacer tube	entretoise	tubo distanciador
32	00 72 140		1	Scheibe 5,2x12x0,5	washer	rondelle	arandela
33	00 18 257		1	Linsenschraube 5x25	screw	vis	tornillo

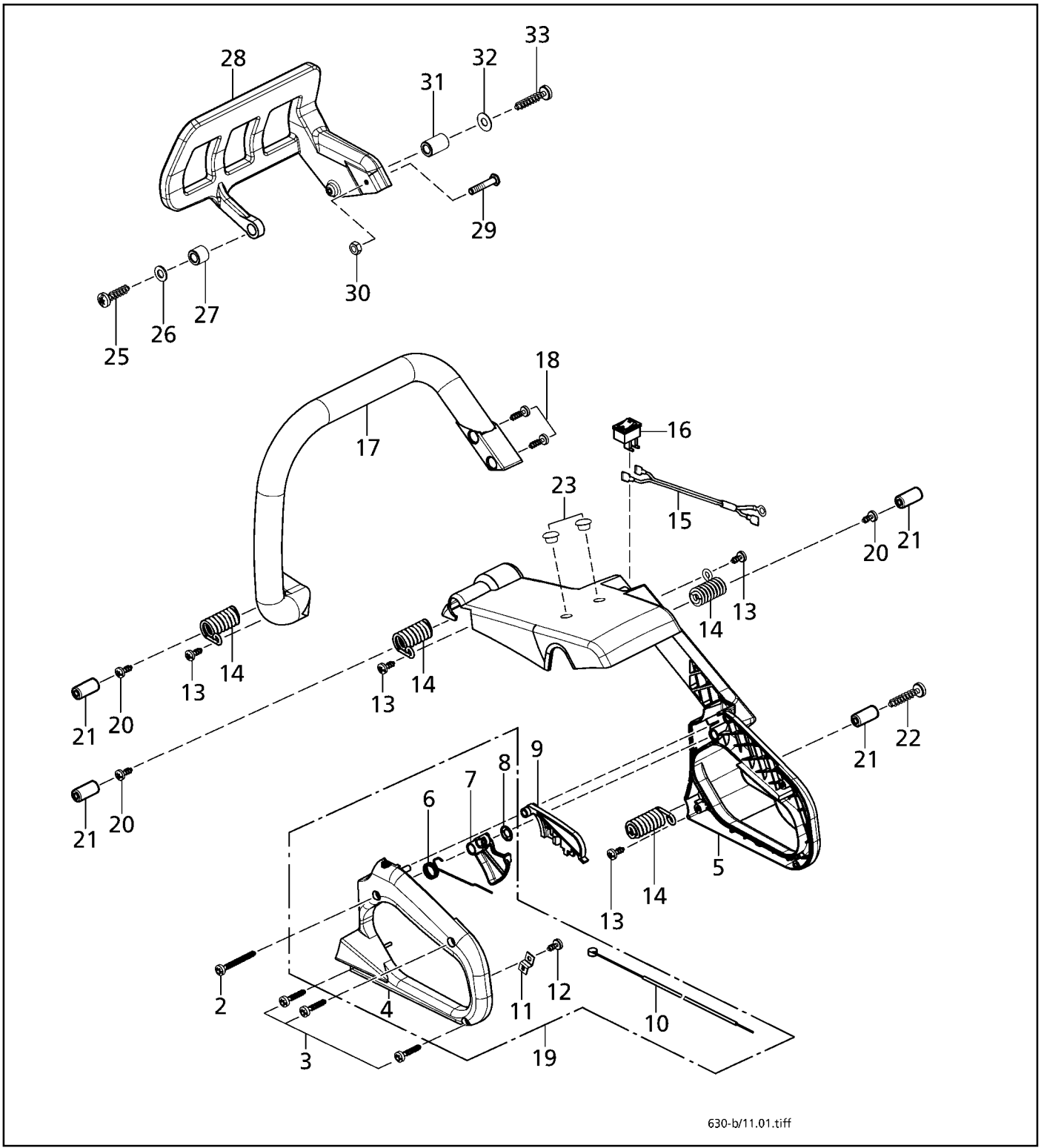

Bild-Nr. Pos.-No. Pos.-No. Pos.-No.	Bestell-Nr. Order-No. No. de Cde. Ref.-Nr.	Modell Type Modèle Modelo	Menge Quantity Nombres Cantidad	Starter	Starter	Lanceur	Arranque
1	26 00 306		1	Starter, kompl.	starter, compl.	lanceur, compl.	arranque, compl.
2	00 69 889		1	SKS "SOLO"	decal "SOLO"	autocollant "SOLO"	adhesivo "SOLO"
3	21 00 891		1	Startergehäuse	starter housing	carter lanceur	caja de arranque
4	00 63 170 25		1	Starterseil 3x850	starter rope	corde de lanceur	cuerda de arranque
5	20 74 570		1	Startergriff	starter grip	poignée lanceur	empuñadura arranque
6	26 00 283		1	Federkassette	spring cassette	cassette de ressort	caja de resorte
7	20 74 992		1	Seilrolle	rope pulley	poulie	roldana
8	20 74 135		1	Starterklinke	starter pawl	cliquet de lanceur	trinquete
9	20 74 136		1	Kulisse	template	coulisse	colisa
10	00 73 417		1	Federstecker 1,4	pin	goupille	enchufe
11	00 18 363		3	Linsenschraube 5x20	screw	vis	tornillo

Bestell-Nr. Order-No. No. de Cde. Ref.-Nr.	Menge Quantity Nombres Cantidad	Seite page page pagina	Bestell-Nr. Order-No. No. de Cde. Ref.-Nr.	Menge Quantity Nombres Cantidad	Seite page page pagina	Bestell-Nr. Order-No. No. de Cde. Ref.-Nr.	Menge Quantity Nombres Cantidad	Seite page page pagina	Bestell-Nr. Order-No. No. de Cde. Ref.-Nr.	Menge Quantity Nombres Cantidad	Seite page page pagina
00 10 231	1	5	00 55 101	1	5	05 10 984	1	5	27 00 345	1	5
00 18 110	2	4	00 55 134	1	4	05 10 985	1	5	27 00 403	1	5
00 18 226	2	4	00 55 216	1	4	05 10 986	1	5	27 00 410	1	5
00 18 257	1	7	00 55 267	2	4	05 10 987	1	5	27 00 416	1	5
00 18 274	2	4	00 60 120	1	4	05 10 992	1	5	28 00 101	1	6
00 18 274	3	4	00 61 130	1	4	05 40 197	1	5	28 00 101	1	7
00 18 274	2	7	00 62 280	2	4	05 40 198	1	5	35 00 196	1	4
00 18 276	1	7	00 62 288	1	5	05 40 199	1	5	35 00 429	1	4
00 18 327	2	4	00 62 332	1	5	05 40 200	1	5	50 74 159	2	7
00 18 336	1	4	00 63 170 25	1	8	05 40 201	1	5	60 31 993	1	4
00 18 340	4	4	00 64 300	1	5	05 40 202	1	5	60 32 130	1	5
00 18 354	1	6	00 64 319	1	5	05 40 991	1	5	60 32 640	1	5
00 18 354	1	7	00 64 407	1	5	06 10 533	1	4	60 32 690	1	7
00 18 356	3	6	00 64 441	1	5	20 31 249 25	1	4	60 42 630	1	4
00 18 358	1	6	00 66 381	1	5	20 48 140	1	4	60 43 323	1	5
00 18 361	4	6	00 66 455	1	4	20 48 386	1	4	60 43 630	1	6
00 18 361	3	7	00 69 106	1	4	20 48 389	1	5	60 43 630	1	7
00 18 362	1	4	00 69 347	1	5	20 48 390	1	5	60 63 101	1	4
00 18 362	1	5	00 69 348	1	5	20 61 514	1	4	60 71 245	1	5
00 18 362	2	5	00 69 889	1	8	20 61 516	1	4	60 73 102	1	6
00 18 363	1	5	00 70 253	1	4	20 63 212	1	5	60 73 102	1	7
00 18 363	1	7	00 70 305	1	4	20 63 370	2	4	60 73 103	1	6
00 18 363	3	8	00 71 153	2	4	20 74 135	1	8	60 73 104	1	7
00 18 380	1	5	00 71 226	2	4	20 74 136	1	8	60 73 105	1	7
00 18 399	1	5	00 72 140	4	4	20 74 570	1	8	60 74 116	1	4
00 18 420	1	5	00 72 140	4	5	20 74 905	1	4	60 74 117	1	4
00 18 423	4	5	00 72 140	1	7	20 74 992	1	8	60 74 118	1	6
00 20 145	1	4	00 72 141	1	4	21 00 364	2	4	60 74 118	1	7
00 20 214	1	4	00 72 144	6	4	21 00 891	1	8	60 74 120	1	4
00 28 118	1	7	00 72 148	2	4	22 00 113	1	4	60 74 130	4	7
00 28 137	2	5	00 73 130	1	6	22 00 630	1	4	60 74 136	1	5
00 30 101	1	4	00 73 130	1	7	22 00 633	1	4	60 74 137	1	5
00 30 102	1	4	00 73 220	1	4	22 00 987	1	4	60 74 940	1	4
00 30 108	1	4	00 73 352	1	5	22 00 989	1	4	60 74 968	1	6
00 30 108	1	7	00 73 360	1	5	23 00 138	1	4	60 74 975	1	4
00 31 194	1	4	00 73 381	1	4	23 00 481	1	4	61 00 134	1	4
00 31 333	1	4	00 73 397	4	6	23 00 730	1	4	61 00 136	1	5
00 33 230	1	7	00 73 417	1	8	23 00 812	1	4	61 00 412	1	4
00 33 231	1	7	00 80 343	1	5	23 00 815	1	4	62 00 134	1	4
00 33 268 25	4	5	00 80 494	1	5	24 00 278	1	4	63 00 175	1	4
00 35 160	1	6	00 84 477	1	7	25 00 103	1	5	63 00 208	1	4
00 35 160	1	7	00 84 621	1	5	25 00 196	1	4	68 00 334	1	4
00 40 188	1	5	00 84 868	1	6	25 00 209	1	4	68 00 348	1	7
00 41 104	1	5	05 10 305	1	5	26 00 283	1	8	69 00 136	1	5
00 44 130	1	4	05 10 931	1	5	26 00 306	1	8	69 00 600	1	5
00 54 237	2	4	05 10 932	1	5	27 00 322	1	5	69 00 744	1	5
									69 00 900	1	5

Allgemeine Richtlinien für die Bestellung von Original SOLO Ersatzteilen:

Voraussetzung für eine reibungslose Erledigung sind folgende Angaben:

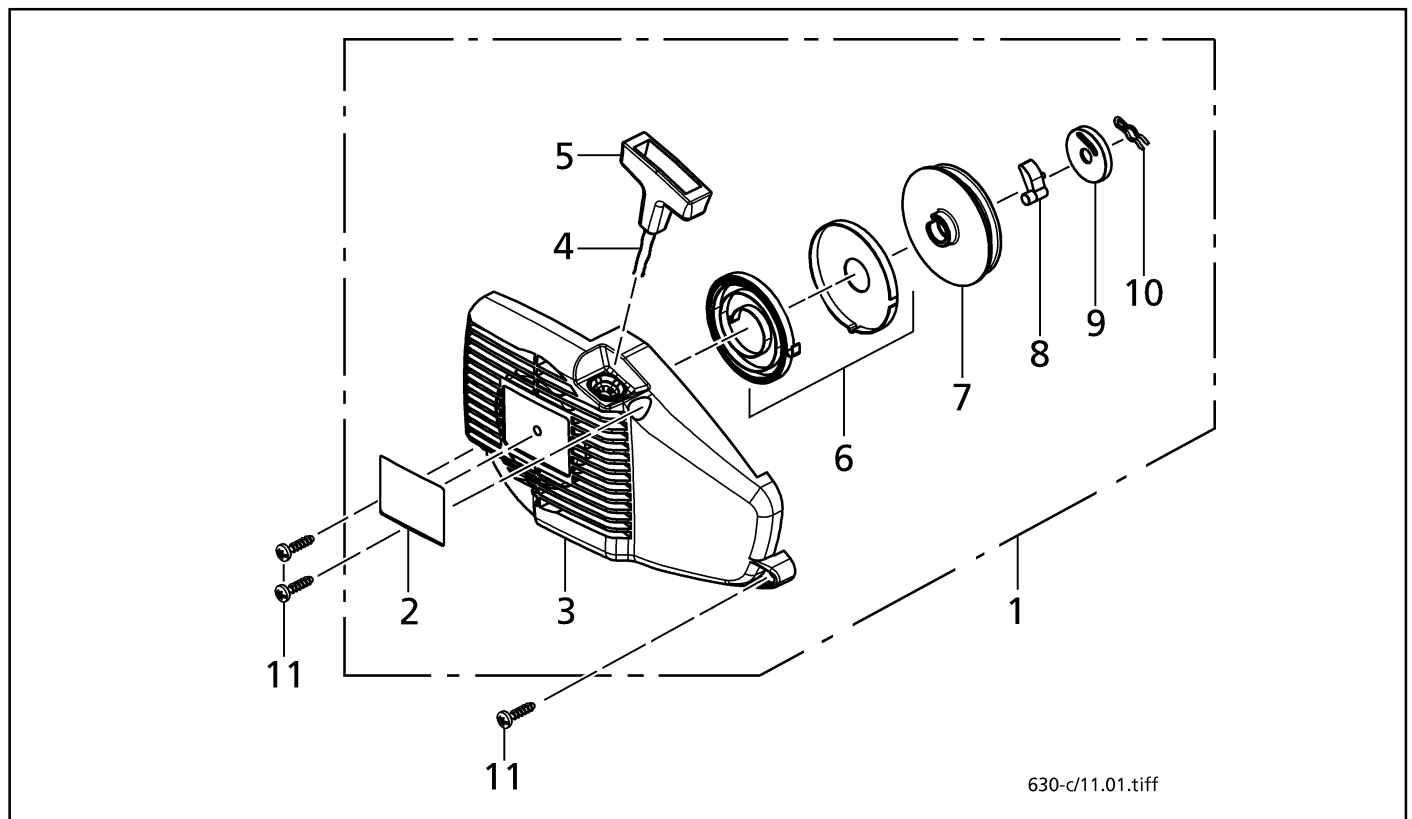
1. Ersatzteil-Bestellnummer
2. Gewünschte Anzahl
3. Typenbezeichnung des Geräts

Diese Ersatzteilliste ist für die Lieferung und Ausstattung von SOLO Erzeugnissen unverbindlich.

Im Interesse der technischen Weiterentwicklung bleiben Konstruktionsänderungen vorbehalten.

General Directions for Ordering Original SOLO Spare Parts:

Spare parts orders are to be placed with the SOLO Sales Branch or SOLO Distributor. For correct and diligent processing of your order, please give the following information:

1. Spare Part number
2. Quantity
3. Model and serial number
4. Shipping instructions

Delivery is made in accordance with our general sales and delivery conditions. This spare parts list is non-committal for us with regard to delivery and layout of SOLO products. In favour of technical improvements, design modifications are subject to change without notice.

Directives générales pour les commandes de pièces de rechange d'origine SOLO:

Il est indispensable de préciser dans toutes les commandes de pièces:

1. - le numéro de référence de la pièce
2. - la quantité
3. - le type de la machine
4. - le mode d'expédition

Les livraisons sont effectuées dans le cadre de nos conditions générales de vente. Toutes modifications réservées.

Directivas Generales de pedido de la firma SOLO:

Por adelantado de un arreglo sin dificultades necesitamos siguientes indicaciones:

1. Número de repuesto
2. Numero de cantidad
3. Modelo y número de serial
4. Instrucción de Envío

Este lista de repuestos no es obligatoria para los envíos y/o forma de equipo de los productos SOLO.

En el interés del constante desarrollo debemos reservarnos el derecho de cambios.

SOLO Kleinmotoren GmbH

Postfach 60 01 52
D-71050 Sindelfingen
Germany

Telefon 07031/301-0
Telefax 07031/301-130
Export 07031/301-149

<http://www.solo-germany.com>
e-mail: info@solo-germany.com

Zentral-Ersatzteilservice
Telefon 07031/301-209
Telefax 07031/301-206

05/02

