

McCULLOCH®

MODEL NAME	(+)SERIAL NUMBER PREFIX	MODEL NUMBER	BAR & CHAIN	ENGINE SIZE
MS1635AV	-	-	16"	35cc
MS1838AV	-	-	18"	38cc
EAGER BEAVER 2116	11-/21-	600035-08	16"	35cc
EAGER BEAVER 2116	11-/21-	600035-14	16"	35cc
EAGER BEAVER 2116	11-	600035-20	16"	35cc
EAGER BEAVER 2116	11-	600035-32	16"	35cc
EAGER BEAVER 2116	11-/21-	600035-35	16"	35cc
EAGER BEAVER 2316	11-/21-/22-	600038-10	16"	38cc
EAGER BEAVER 2316	11-	600038-22	16"	38cc
EAGER BEAVER 2318	11-	600038-23	18"	38cc
EAGER BEAVER 2318	11-/21-	600038-28	18"	38cc
EAGER BEAVER 2318	11-/21-	600038-12	18"	38cc
MAC 3516	11-/21-	600035-10	16"	35cc
MAC 3516	11-/21-	600035-12	16"	35cc
MAC 3516	11-/21-	600035-17	16"	35cc
MAC 3516	11-/21-/22-	600035-18	16"	35cc
MAC 3516	11-	600035-19	16"	35cc
MAC 3516	11-	600035-34	16"	35cc
MAC 3516	11-/21-	600035-50	16"	35cc
MAC 3516	11-	600035-53	16"	35cc
MAC 3516	11-/21-	600035-54	16"	35cc
MAC 3516	11-/21-	600035-57	16"	35cc
MAC 3516	11-/21-	600035-59	16"	35cc
MAC 3816	11-/21-	600038-31	16"	38cc
MAC 3816	11-/21-	600038-76	16"	38cc
MAC 3816	11-/21-	600038-77	16"	38cc
MAC 3818	11-/21-	600038-08	18"	38cc
MAC 3818	11-/21-	600038-18	18"	38cc
MAC 3818	11-	600038-27	18"	38cc
MAC 3818	11-/21-	600038-29	18"	38cc
MAC 3818	11-	600038-58	18"	38cc
MAC 3818	11-/21-/22-	600038-65	18"	38cc
MAC 3818	11-/21-/22-	600038-67	18"	38cc
MAC 3818	11-/21-	600038-68	18"	38cc
MAC 3818	11-	600038-71	18"	38cc
MAC 3818	11-/21-	600038-73	18"	38cc
MAC 3818	11-/21-	600038-81	18"	38cc
MACCAT 16	11-	600038-69	16"	38cc
MACCAT 18	11-/21-	600038-30	18"	38cc
MACCAT 18	11-	600038-46	18"	38cc
MACCAT 18	11-/21-	600038-72	18"	38cc
MACCAT 18	11-/21-	600038-74	18"	38cc
MACCAT 18	21-	600038-82	18"	38cc
MACCAT SUPER 16	11-/21-	600038-14	16"	38cc
MACCAT SUPER 16	11-	600038-24	16"	38cc
MACCAT SUPER 18	11-/21-/22-	600038-16	18"	38cc
MACCAT SUPER 18	11-/21-	600038-19	18"	38cc
MACCAT SUPER 18	11-/21-	600038-20	18"	38cc
MACCAT SUPER 18	11-/21-	600038-21	18"	38cc
MACCAT SUPER 18	11-	600038-25	18"	38cc
PROMAC 3205	11-/21-/22-	600032-10	14"	32cc
PROMAC 3505	11-/21-	600035-04	16"	35cc
PROMAC 3505	11-/21-/22-	600035-16	16"	35cc
PROMAC 3505	11-	600035-21	16"	35cc
PROMAC 3505	11-	600035-31	16"	35cc
PROMAC 3805	11-/21-/22-	600038-04	18"	38cc
PROMAC 3805	11-	600038-26	18"	38cc
PROMAC 3805	11-	600038-47	18"	38cc
PROMAC 3805	11-	600038-62	16"	38cc
SILVER EAGLE 2116	11-	600035-47	16"	35cc
SILVER EAGLE 2116	11-	600035-48	16"	35cc
SILVER EAGLE 2116	11-	600035-51	16"	35cc
SILVER EAGLE 2116	11-/21-	600035-02	16"	35cc
SILVER EAGLE 2318	11-/21-	600038-02	18"	38cc
SILVER EAGLE 2318	11-	600038-59	18"	38cc
SILVER EAGLE 2318	21-	600038-66	18"	38cc

MARCH 2003

32cc, 35cc and 38cc GASOLINE POWERED ANTI-VIBRATION (AV) CHAIN SAWS

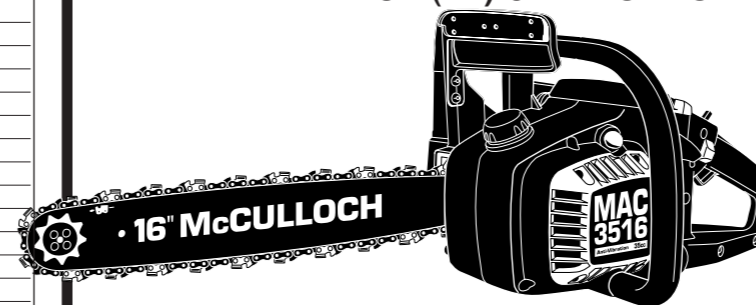

McCulloch products are identified by a model number (in this instance 600035) followed by a suffix number (08). Suffix numbers denote variations in parts or assemblies used in the manufacture of this product.

Illustrated Parts Lists (IPLs) contain a PART NUMBER, DESCRIPTION, UNITS per assembly and STOCKING CODE for each part.

Stocking Codes are:

- A - Dealer stocked. Fast to medium moving part.
- B - Distributor stocked. Medium to slow moving part.
- C - Factory stocked. Slow moving part.

NOTE: The following explains symbols and footnotes in this IPL:

- (-) A dash preceding a PART NUMBER indicates that it is a new part number, different from the one listed in the previous IPL for this unit.
- (.) One or more dots (. Spring, Starter) preceding a part DESCRIPTION indicates the part is included in the kit or assembly described directly above the dot(s).
- (-- --) If four dashes appear in place of a PART NUMBER, the part is not available individually but is included in the next higher assembly or subassembly.
- ①② Circled numbers preceding a DESCRIPTION footnote the part or assembly to additional information on the page.
- (*) An asterisk denotes that choices follow or precede.
- (+) Serial Number Prefix 21- denotes CARB approved unit -- all parts are interchangeable with Serial Number Prefix 11-.

The policy of McCulloch is one of continual improvement in design, manufacturing and engineering advancement wherever possible to assure still finer power tools. Hence, specifications, equipment colors, design and manufacturer's suggested list prices are subject to change without notice. McCulloch reserves the right to make such changes without prior notification or obligation to backfit or supply backfit components for units previously shipped from the factory.

ILLUSTRATED PARTS LIST

P.O. Box 31567
Tucson, Arizona 85751-1567 • U.S.A.

FIGURE 1

GENERAL ASSEMBLY

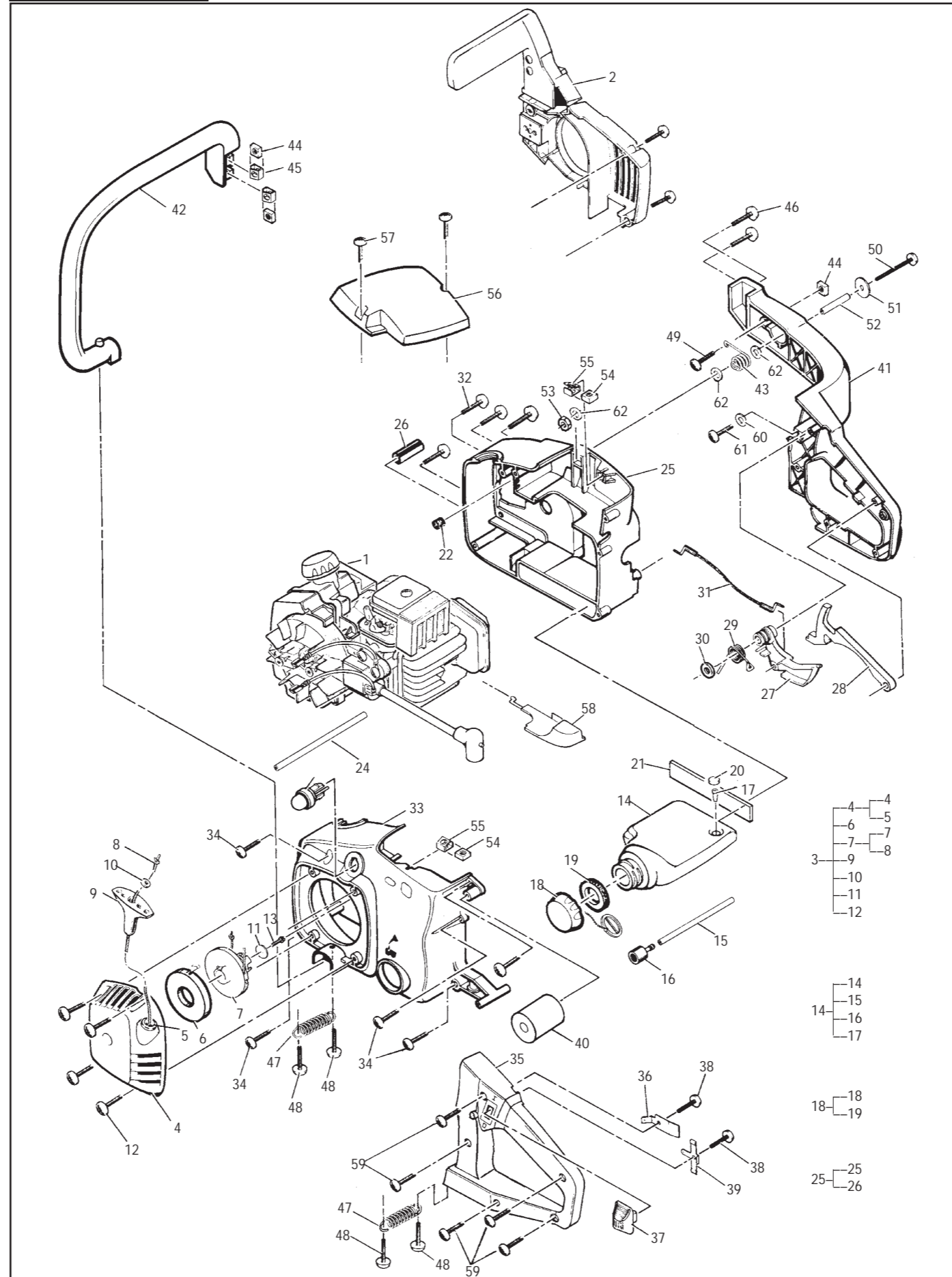

GENERAL ASSEMBLY

FIGURE 1

ITEM NO.	STK CODE	PART NUMBER	DESCRIPTION	UNITS PER ASY	ITEM NO.	STK CODE	PART NUMBER	DESCRIPTION	UNITS PER ASY
1	-	FIGURE 2	Powerhead Asy		*33	B	MC-323947-61	Engine Housing, Left, AV, Blk	1
2	-	FIGURE 3	Chain Brake Asy		34	A	MC-300294	Screw, 8-16 x .75 Tr Hd, Plastite	5
3	A	MC-300264	Starter Housing Asy, Yellow	1	35	B	MC-322164	Handle, Left Rear, Black, AV	1
4	B	MC-301044	Housing/Rope Guide Asy, Yellow	1	36	B	MC-322178	Contact, Ground Stud, AV	1
5	-	-- --	Rope Guide	1	37	A	MC-68846	Button, Stop Switch	1
6	A	MC-300475	Spring, Starter Rewind	1	38	A	MC-223357	Screw, 8-16 Plastite	2
7	A	MC-301043	Rope/Drum Asy (32cc)	1	39	B	MC-224844	Contact, Ignition	1
8	A	MC-300300	Rope, Starter 50 inch	1	40	A	MC-322193	Isolator, Rubber	1
9	A	MC-87851	Handle, Starter	1	41	A	MC-322163	Handle, Right Rear, Black	1
10	A	MC-223944	Bushing, Starter	1	42	A	MC-322162-01	Handle, Front	1
11	A	MC-300297	Washer, .19 ID x .68 OD	1	43	A	MC-322165	Spring, Extension	1
12	A	MC-300294	Screw, 8-16 x .75 Torx Hd Plast	1	44	A	MC-218005	Nut, Square 10-24	3
13	A	MC-300294	Screw, 8-16 x .75 Torx Hd Plastite	4	45	A	MC-300292	Retainer, Nut	2
14	B	MC-300260	Oil Tank Asy	1	46	A	MC-111226	Screw, 10-24 x .62 Tr Hd Torx	2
15	A	MC-300289	Hose, Oil Pick-up	1	47	A	MC-322166	Spring, Extension	2
16	A	MC-92465	Filter, Oil	1	48	A	MC-300294	Screw, 8-16 x .75 Tr hd Plastite	4
17	A	MC-300256	Valve, Duckbill	1	49	A	MC-217935	Screw, 10-24 x .50 Tr Tors	1
18	A	MC-300565	Oil Cap Asy	1	50	A	MC-218083	Screw, 10-24 x 2.0 Tr Torx	1
19	-	-- --	Gasket	1	51	A	MC-322176	Washer, 2.0 x 7.8 in. OD	1
20	A	MC-300259	Filter, Foam	1	52	B	MC-322175	Spacer, 0.2 ID x 1.0 Lg	1
21	B	MC-322195	Spacer, Oil Tank	1	53	B	MC-111135	Nut, Hex Lock 10-24	1
22	A	MC-300259	Filter, Foam	1	54	A	MC-218005	Nut, Square 10-24	2
23	A	MC-224242-02	Primer, Remote	1	55	A	MC-300292	Retainer, Nut	2
24	A	MC-300298	Hose	1	56	B	MC224830	Cover, Air Filter	1
25	B	MC-301056	Housing/Pin Asy, Right	1	57	A	MC-111099	Screw, 10-24 x .625 Pn Hd Torx	2
26	-	-- --	Pin, Roll 1/4 x 1.0 L	1	58	A	MC-224826-01	Rod, Choke	1
27	A	MC-224821	Trigger, Throttle	1	59	A	MC-300294	Screw, 8-16 x .75 Tr Hd Plastite	5
28	B	MC-224822	Latch, Throttle	1	60	A	MC-300297	Washer, .19 ID x .68 OD	1
29	A	MC-224823	Spring, Torsional	1	61	A	MC-300294	Screw, 8-16 x .75 Tr Hd Plastite	1
30	B	MC-111128	"O" Ring	1	62	A	MC-93469	Washer, .469 OD x .222 ID	3
31	B	MC-322409	Cable, Throttle	1					
32	A	MC-111226	Screw, 10-24 x .62 Tr Hd Torx	4					

ENGINE SPECIFICATIONS

Displacement, cc (ci)	.32cc (1.95) 35cc (2.14) 38cc (2.32)
Spark Plug	RDJ7Y
Spark Plug Gap	.025 in. (0.63mm)
Flywheel to Ignition Gap	.010-0.015 in. (0.254-0.381mm)
Max Power Speed	.8000 RPM
Idle Speed	.2800-3300 RPM
Clutch Engagement Speed	.3800-4000 RPM
Max No Load Speed	.11,000 RPM
Fuel Tank Capacity	.10 fl. oz
Oil Tank Capacity	.6.1 fl. oz

TORQUE SPECIFICATIONS

DESCRIPTION	FASTENER PART NO.	FIG/ ITEM	TORQUE (IN/LBS)	LOCTITE
Right Hsg to C'case	111226	1/32	40-50	262
Oil Pump to C'case	111226	2/9	30-40	262
Carb Insul to Cyl	217937	2/65	30-40	262
Spark Plug	322208	2/50	150	--
Flywheel Nut	110961	2/40	180	--
Clutch Nut	111079	2/82	180	--
Muffler Screws	111093	2/59	50	--
Carburetor Screws	218083	2/69	30-40	262

FIGURE 2

POWERHEAD ASSEMBLY

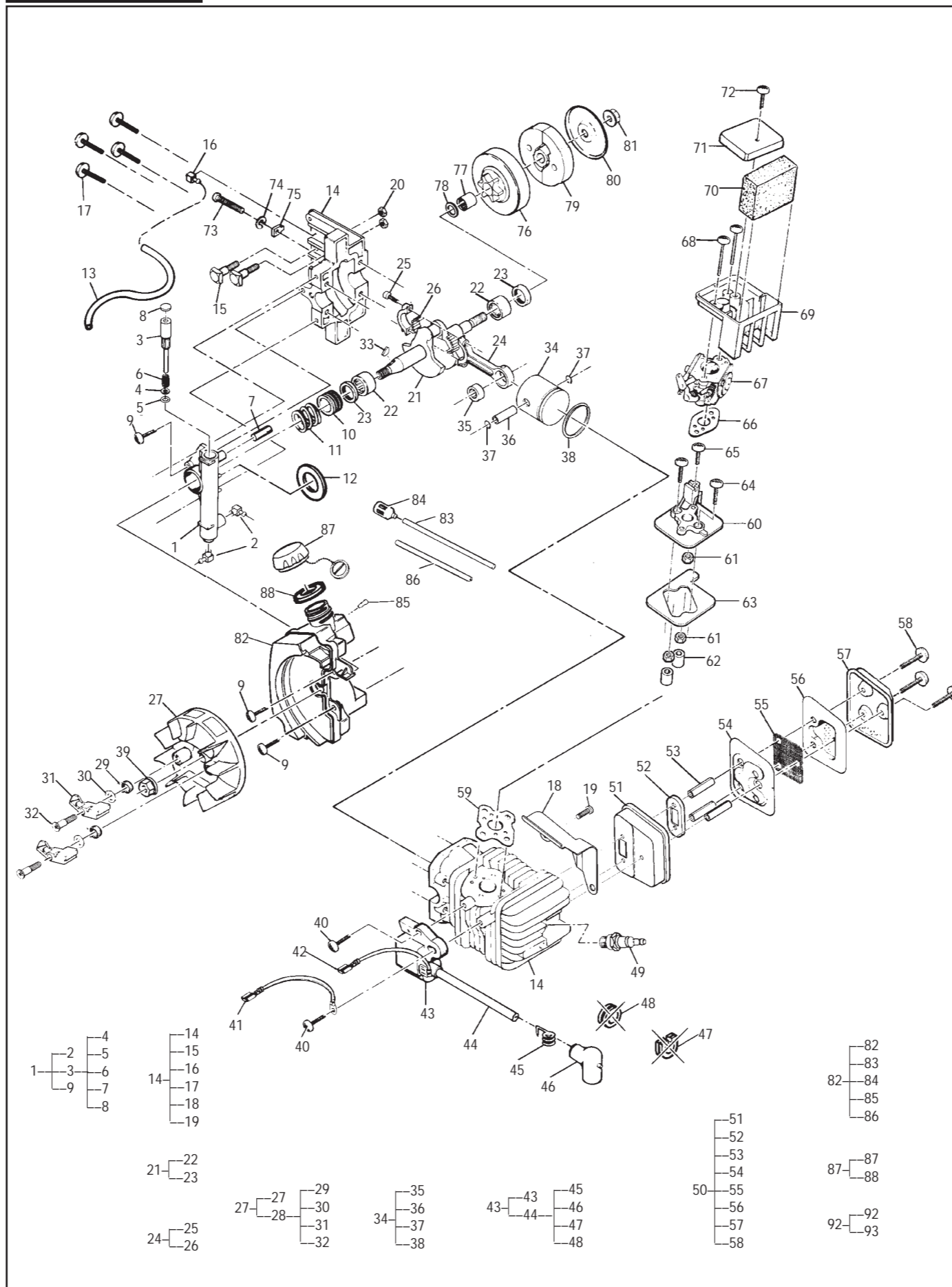

POWERHEAD ASSEMBLY

FIGURE 2

ITEM NO.	STK CODE	PART NUMBER	DESCRIPTION	UNITS PER ASY	ITEM NO.	STK CODE	PART NUMBER	DESCRIPTION	UNITS PER ASY
1	A	MC-301304	Oil Pump Asy	1	50	B	MC-301045	Muffler Asy	1
2	B	MC-322182	Fitting	2	51	-	---	Body	1
3	A	MC-301084	Kit, Gear/Plunger Asy	1	52	-	---	Plate, Reinforcing	1
4	A	MC-110582	Washer	1	53	-	---	Spacer	3
5	-	---	O-Ring	1	54	-	---	Baffle, Inner Muffler	1
6	-	---	Spring	1	55	B	MC-300286	Screen, Spark Arrester	1
7	-	---	Pin, Dowel	1	56	-	---	Baffle, Outer	1
8	B	MC-322187	Plug, Oil Pump	1	57	-	---	Cover, Muffler	1
9	A	MC-111226	Screw, 10-24 x .62 Tr Hd Torx	2	58	B	MC-111093	Screw, 10-24 x 1.75 Tr Hd Torx	3
10	A	MC-224814	Worm Gear	1	59	A	MC-300265	Gasket, Insulator	1
11	A	MC-224840	Spring, Compression	1	60	A	MC-224820	Insulator, Carburetor	1
12	A	MC-300295	Seal, Foam, Oil Pump	1	61	A	MC-218315	Nut, Hx 10-24	3
13	A	MC-300288	Connecting Hose	1	62	A	MC-322188	Spacer, Rubber	2
14	A	MC-301284	Short Block Asy	1	63	A	MC-224850	Seal, Foam	1
15	A	MC-83856-01	Bolt, Bar	2	64	B	MC-217937	Screw, Tr 10-24 x 1.00 Torx	2
16	B	MC-300257	Fitting	1	65	A	MC-217936	Screw, Tr 10-24 x .75 Torx	1
17	A	MC-111083	Screw, 12-24 x 1.0 Hx Wshr Hd	4	66	A	MC-300293	Gasket, Carburetor	1
18	C	MC-323923	Baffle, Air	1	67	-	FIGURE 4	Carburetor/Choke Asy	1
19	A	MC-111054	Screw, 10-24x.625	1	68	A	MC-218083	Screw, Tr 10-24 x 2.0 Torx	2
20	A	MC-110676	Nut, Hx 1/4-28 Flange	2	69	C	MC-224824	Box, Air Filter	1
21	-	---	Crankshaft/Bearing Asy	1	70	A	MC-224831	Filter, Air	1
22	A	MC-213282	Bearing, C'shaft	2	71	B	MC-224825	Shield, Carburetor	1
23	A	MC-83859	Seal, C'shaft Oil	2	72	A	MC-111055	Screw, 10-14 x .625 Plastite	1
24	-	---	Connecting Rod/Bearing Asy	1	73	A	MC-268656-33	Gas Bar Adj Screw Nut & Ring	1
25	-	---	Screw, Conn Rod	2	74	-	---	Ring, Retaining	1
26	-	---	Set, Roller Pins	1	75	-	---	Nut, Bar Adjusting	1
27	B	MC-302220	Flywheel/Pawl Asy	1	76	A	MC-302768	Drum/Sprocket/Bearing Asy	1
28	A	MC-300763-01	Kit, Flywheel Pawls	2	77	A	MC-91117	Bearing	1
29	A	MC-216982	Spring, Starter Pawl	2	78	B	MC-215259	Washer, Sprocket	1
30	C	MC-111131	Washer, Sp .469 OD x .222 ID	2	79	A	MC-301463	Kit, Clutch Asy	1
31	-	---	Pawls	2	80	B	MC-300276	Plate, Dust	1
32	A	MC-322721	Pin, Starter Pawl	2	81	A	MC-111079	Nut, Clutch, 5/16-24 LH	1
33	A	MC-102164	Key, Flywheel	1	82	A	MC-301834	Fuel Tank Asy	1
34	-	---	Kit, Piston, 38cc	1	83	A	MC-300289	Hose, Fuel Pickup	1
35	-	---	Bearing, Needle- Drawn Cup	1	84	A	MC-216985	Filter, Fuel	1
36	-	---	Pin, Piston	1	85	A	MC-322199	Valve, Duckbill	1
37	-	---	Ring, Snap	2	86	A	MC-300290	Hose, Primer Retain	1
38	-	---	Piston, Ring, 38cc	1	87	A	MC-300564	Cap, Fuel Asr	1
39	A	MC-110961	Nut, Hx 5/16-24	1	88	-	---	Gasket, Fuel Cap	1
40	A	MC-217936	Screw, Tr 10-24 x .75 Torx	2					
41	B	MC-300555	Wire Asy, Ground	1					
42	B	MC-300556	Wire Asy, Stop Switch	1					
43	A	MC-302138	Ignition Asy	1					
44	A	MC-223884	Kit, Plug Wire	1					
45	A	MC-102556	Connector	1					
46	A	MC-95266	Boot	1					
47	B	MC-110995	Grommet	1					
48	B	MC-215533-01	Grommet	1					
49	A	MC-322208	Spark Plug RDJ7Y	1					

① 32/35cc piston and cylinder are no longer available; for replacement parts, the 38cc Shortblock Asy, PN 301284, must be used.
 ② Contents of 38cc Shortblock Asy, PN 301284
 ③ Not used on these models

FIGURE 3

CHAIN BRAKE ASSEMBLY

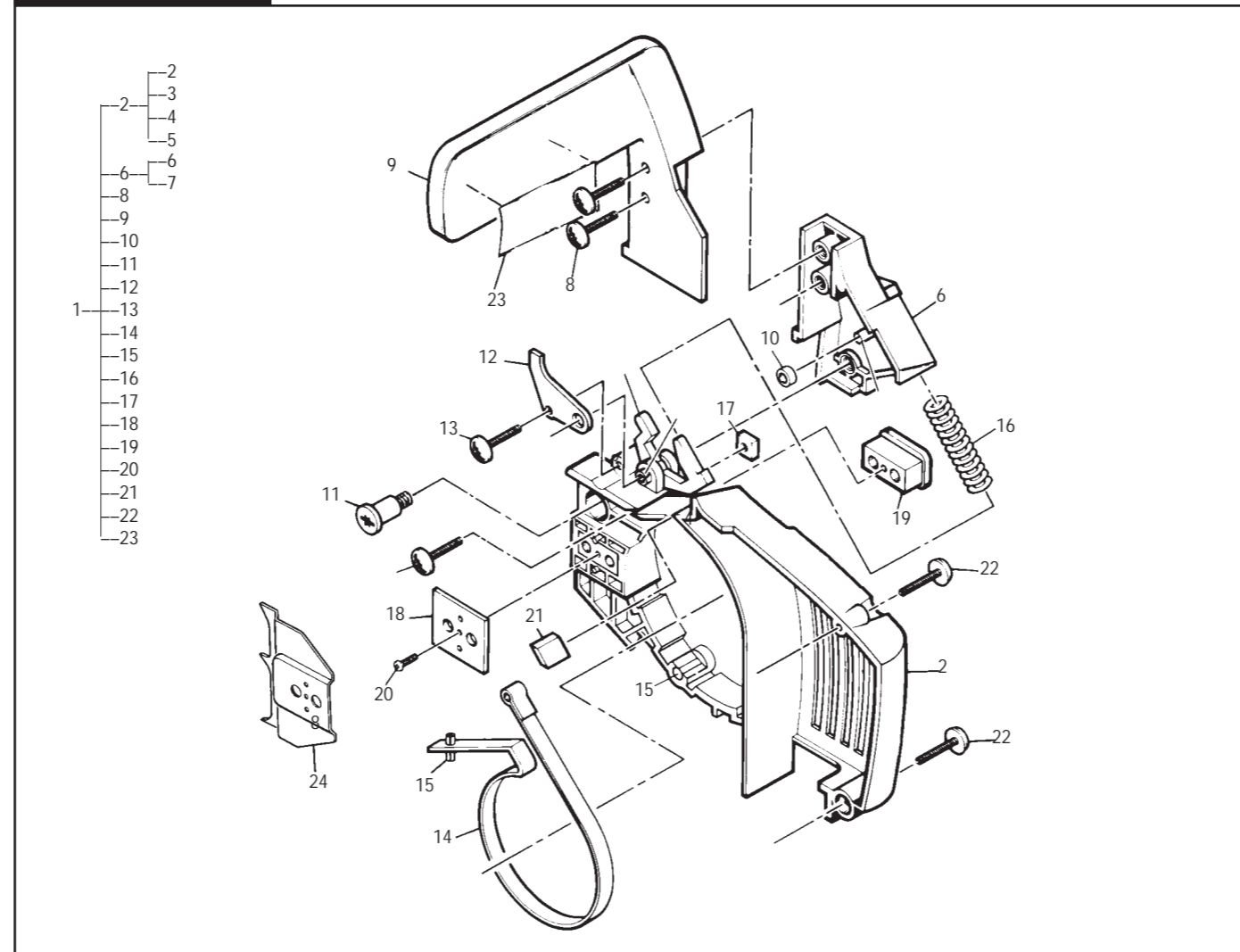

ITEM NO.	STK CODE	PART NUMBER	DESCRIPTION	UNITS PER ASY	ITEM NO.	STK CODE	PART NUMBER	DESCRIPTION	UNITS PER ASY
1	C	MC-301558	Brake Kit Asy, Yellow	1	16	A	MC-322204	Spring, Compression	1
2	C	MC-301559	Housing Kit Asy, Yellow	1	17	A	MC-218005	Nut, Square 10-24	1
3	C	MC-216755	Latch, Chain Brake	1	18	B	MC-300275	Shield	1
4	-	---	Dowel, Spring	1	19	B	MC-300271	Spacer, Bar Pad	1
5	-	---	Pin, Dowel	2	20	C	MC-111101	Screw, 4-40 x 5/16 Taptite	1
6	B	MC-301038	Lever, Actuating	1	21	A	MC-322194	Seal, Foam	1
7	-	---	Pin, Dowel	1	22	B	MC-300299	Screw, 8-16 x 1.0 Tr Hd Plastite	2
8	A	MC-111226	Screw, 10-24 x .62 Tr Hd Torx	3	23	B	MC-46703-41	Label, Safety	1
9	A	MC-323082	Guard, Hand	1	24	B	MC-322181	Ⓢ Spike, Bucking	1
10	B	MC-224849	Roller	1					
11	B	MC-224847	Screw, Shoulder	1					
12	B	MC-224848	Stop, Brake	1					
13	A	MC-300294	Screw, 8-16 x .75 Tr Hd Plastite	1					
14	A	MC-301037	Band, Brake	1					
15	-	---	Pin, Spring (.125 x .50)	1					

Ⓢ Optional equipment

BAR AND CHAIN INFORMATION

BAR AND CHAIN SIZE	BAR PART NUMBER	CHAIN PART NUMBER	CHAIN SPECIFICATIONS	SERVICE TOOLS	
				FILE AND GUIDE PN	FILE PN (Description)
14"	MC-214235-33	MC-214919-33	MPG370GLX49cl	301992-33 (5/32)	214217-33 (5/32)
16"	MC-214236-33	MC-214925-33	MPG370GLX54cl		
18"	MC-219276-33	MC-219275-33	MPG370GLX60cl		

FIGURE 4

CARBURETOR ASSEMBLY

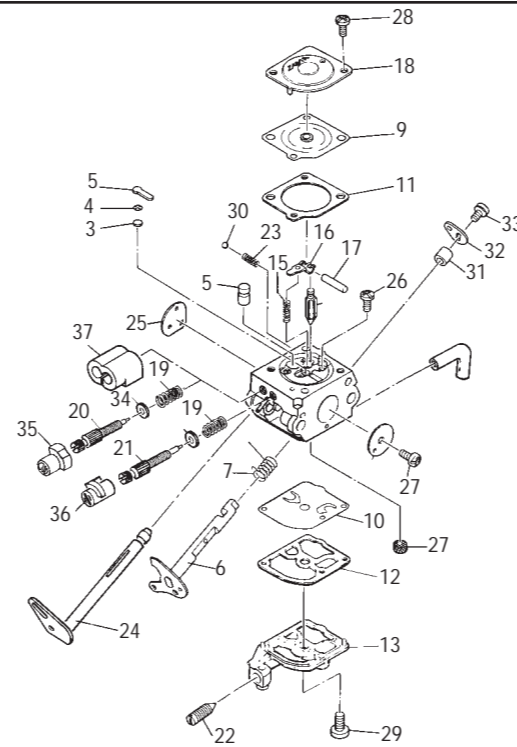

ITEM NO.	STK CODE	PART NUMBER	DESCRIPTION	UNITS PER ASY	ITEM NO.	STK CODE	PART NUMBER	DESCRIPTION	UNITS PER ASY
-	B	MC-323653-03	④ Carburetor, Zama CU1M28C		-	B	MC-323653-04	④ Carburetor, Walbro WT 438	
-	B	MC-323654-03	⑤ Carburetor, Zama CU1M33C		-	B	MC-323654-04	⑤ Carburetor, Walbro WT 439	
B		MC-324947-01	⑥ Carburetor, Zama C1QM36		1	---	---	① Strainer	1
1	---	---	① Strainer	1	2	---	---	① Plug, Welch	1
2	---	---	① Plug, Welch	1	3	---	---	① Valve, Check	1
3	---	---	① Valve, Check	1	4	---	---	Retainer, Check Valve	1
4	---	---	Retainer, Check Valve	1	5	---	---	Nozzle Asy, Check Valve	1
5	---	---	Nozzle Asy, Check Valve	1	6	---	---	Shaft Asy, Throttle	1
6	---	---	Shaft Asy, Throttle	1	7	---	---	Spring, Throttle Return	1
7	---	---	Spring, Throttle Return	1	8	---	---	Valve, Throttle	1
8	---	---	Valve, Throttle	1	9	---	---	①② Diaphragm Asy, Metering	1
9	---	---	①② Diaphragm Asy, Metering	1	10	---	---	①② Diaphragm, Pump	1
10	---	---	①② Diaphragm, Pump	1	11	---	---	①② Gasket, Metering Chamber	1
11	---	---	①② Gasket, Metering Chamber	1	12	---	---	①② Gasket, Pump	1
12	---	---	①② Gasket, Pump	1	13	---	---	Cover, Pump	1
13	---	---	Cover, Pump	1	14	---	---	① Valve, Inlet Needle	1
14	---	---	① Valve, Inlet Needle	1	15	---	---	① Spring, Metering Lever	1
15	---	---	① Spring, Metering Lever	1	16	---	---	① Lever, Metering	1
16	---	---	① Lever, Metering	1	17	---	---	① Pin	1
17	---	---	① Pin	1	18	---	---	Cover, Metering Chamber	1
18	---	---	Cover, Metering Chamber	1	19	---	---	Spring, Adjust Screw	2
19	---	---	Spring, Adjust Screw	2	20	---	---	Screw, Main Mixture	1
20	---	---	Screw, Main Mixture	1	21	---	---	Screw, Idle Mixture	1
21	---	---	Screw, Idle Mixture	1	22	---	---	Screw, Throttle Adjust	1
22	---	---	Screw, Throttle Adjust	1	23	---	---	Spring, Friction	4
23	---	---	Spring, Friction	4	24	---	---	Shaft Asy, Choke	1
24	---	---	Shaft Asy, Choke	1	25	---	---	Valve, Choke	1
25	---	---	Valve, Choke	1	26	---	---	Screw, Pin	1
26	---	---	Screw, Pin	1	27	---	---	Screw, Throttle/Choke Valve	1
27	---	---	Screw, Throttle/Choke Valve	1	28	---	---	Screw, Metering Chamber	2
28	---	---	Screw, Metering Chamber	2	29	---	---	Screw, Pump Cover	1
29	---	---	Screw, Pump Cover	1	30	---	---	Ball, Steel	1
30	---	---	Ball, Steel	1	31	---	---	Collar	1
31	---	---	Collar	1	32	---	---	Lever, Throttle	1
32	---	---	Lever, Throttle	1	33	---	---	Screw, Throttle Lever	1
33	---	---	Screw, Throttle Lever	1	34	---	---	Washer, Limiter	2
34	---	---	Washer, Limiter	2	35	B	MC-325465	Cap, Limiter, Hi	1
35	B	MC-111216	Cap, Limiter, Hi	1	36	B	MC-325466	Cap, Limiter, Lo	1
36	B	MC-111217	Cap, Limiter, Lo	1	37	---	---	Retainer, Limiter	1
37	---	---	Retainer, Limiter	1					
①	301041	Kit, Carburetor Repair RB-39 (Stk Code A)			①	324013	Kit, Carburetor Repair A1128WT (Stk Code A)		
②	301042	Kit, Gasket/Diaphragm GND-35 (Stk Code A)			②	324009	Kit, Gasket/Diaphragm B1110WT (Stk Code A)		
④	Can be used on 32/35cc models with serial number prefixes 11-, 21-				④	Can be used on 32/35cc models with serial number prefixes 11-, 21-			
⑤	Can be used on 38cc models with serial number prefixes 11-, 21-				⑤	Can be used on 38cc models with serial number prefixes 11-, 21-			
⑥	Can be used on 32/35/38cc models with serial number prefixes 11-, 21-, 22-								



P.O. Box 31567 • Tucson Arizona 85751-1567 • U.S.A.

• MANUFACTURING • SALES • SERVICE •

FOR WARRANTY OR SERVICE, CONTACT THE NEAREST McCULLOCH AUTHORIZED SERVICE CENTER LISTED UNDER 'SAWS' IN YOUR TELEPHONE DIRECTORY YELLOW PAGES.

IF FURTHER ASSISTANCE IS REQUIRED, CALL THIS TOLL-FREE HOT LINE.
PLEASE REFERENCE YOUR MODEL AND SERIAL NUMBER.

1-800-521-8559

MONDAY - FRIDAY - 6:00 AM - 4:30 PM (MST)

www.mccullochpower.com

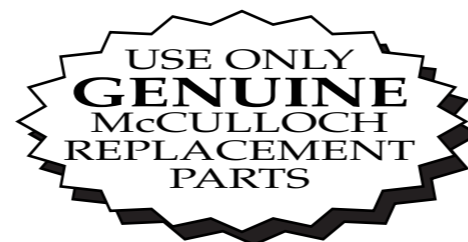

Gas Chain Saw

MS1636NAVCC

ENGINE

36cc, 2-Cycle Engine

Electronic Ignition

For reliable starts in all conditions

Chrome-Plated Cylinder

For longer engine life

SAW CAPABILITIES

16" Bar Length

Cuts logs up to 32" in diameter

Automatic Oiler

Provides consistent lubrication to bar and chain while the saw is running

Sprocket Tip Bar

Increases the RPM of the chain and decreases bar wear

Standard Chain Brake/Hand Guard

Immediately stops the chain when the user's hand contacts the chain brake lever in the event of kickback; for added safety and protection.

Inertia Chain Brake

Immediately stops the chain when the saw encounters inertia produced by kickback

OTHER FEATURES

Carry Case Included

Protects saw in transit, as well as eliminates oil drip while in storage

1-Year Limited Warranty



Carry Case Included



16" Gas Chain Saw
Model: TBD
UPC: TBD

McCULLOCH

Gas Chain Saw

MS1636AVCC

ENGINE

36cc, 2-Cycle Engine

Electronic Ignition

For reliable starts in all conditions

Chrome-Plated Cylinder

For longer engine life

SAW CAPABILITIES

16" Bar Length

Cuts logs up to 32" in diameter

Automatic Oiler

Provides consistent lubrication to bar and chain while the saw is running

Sprocket Tip Bar

Increases the RPM of the chain and decreases bar wear

Standard Chain Brake/Hand Guard

Immediately stops the chain when the user's hand contacts the chain brake lever in the event of kickback; for added safety and protection.

Inertia Chain Brake

Immediately stops the chain when the saw encounters inertia produced by kickback

OTHER FEATURES

Carry Case Included

Protects saw in transit, as well as eliminates oil drip while in storage

Anti-Vibration Handle

Reduced vibration decreases user fatigue.

1-Year Limited Warranty



Carry Case Included



16" Gas Chain Saw
Model: TBD
UPC: TBD

McCulloch