

PRICE 25

HOMELITE

Chain Saw

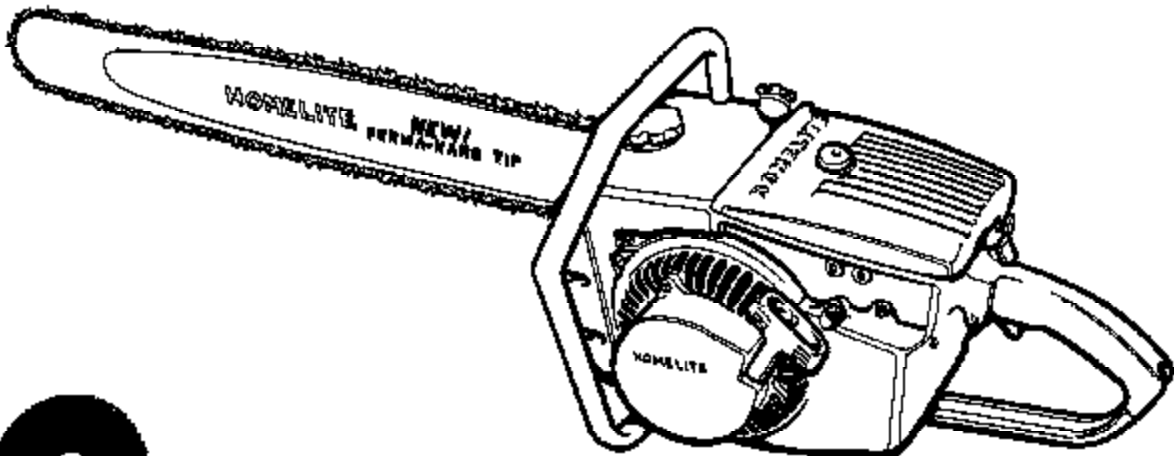

C-52

PARTS LIST

HOMELITE C-52 CHAIN SAW

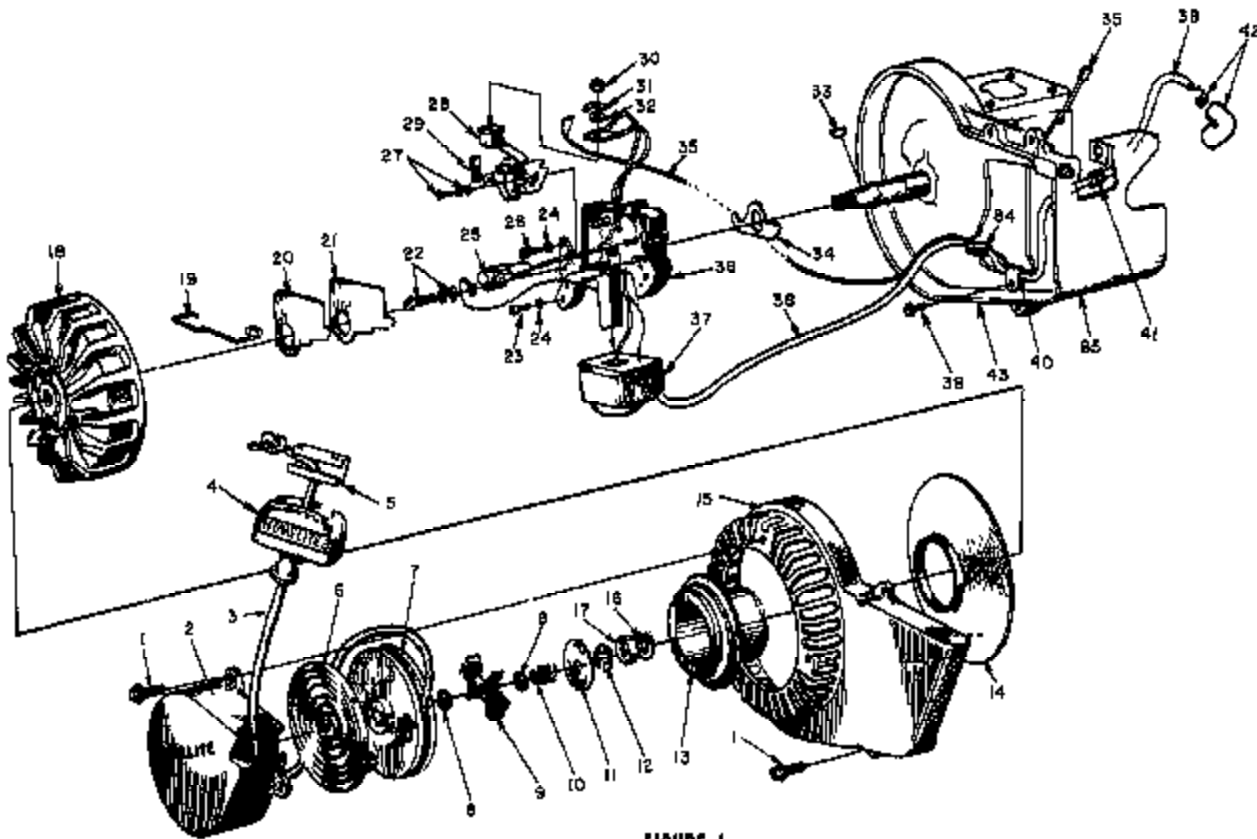

FIGURE 1

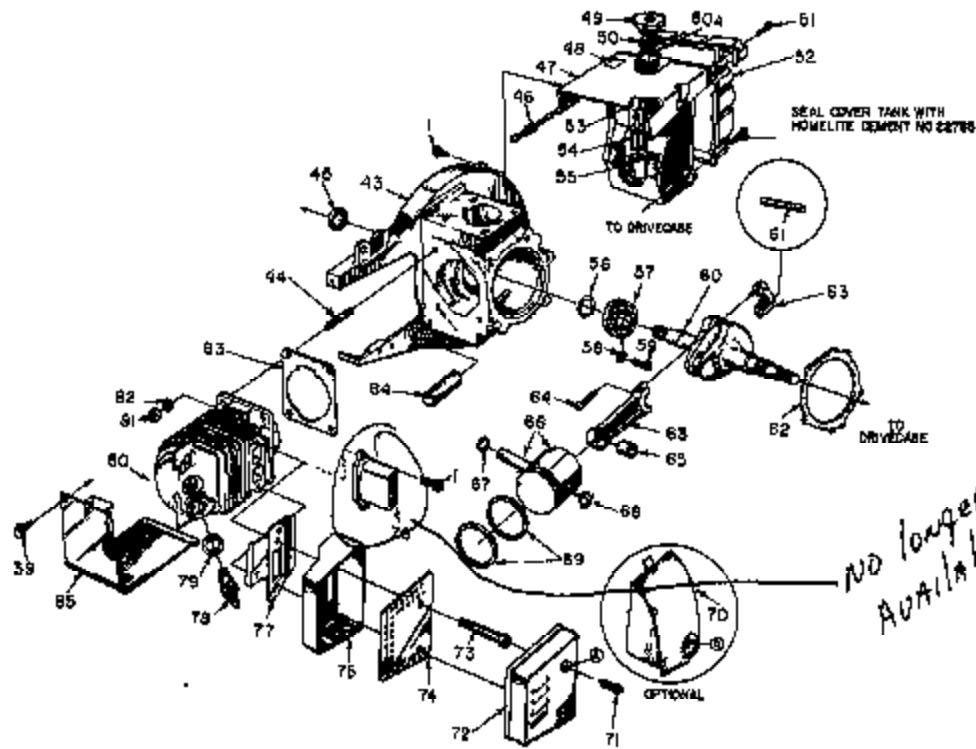

FIGURE 2

HOMELITE C-52 CHAIN SAW

No.	Description	Part No.	Qty.	No.	Description	Part No.	Qty.
1	SCREW - hex hd., 12-24 x 3/4	80897	19	44	Includes: STUD	80871	4
	STARTER ASSEMBLY (complete)	A-58384-1A	1	45	SEAL	88308-A	1
2	Includes: COVER - pulley w/2 roll pins	A-58802-1	1	46	FITTING - fuel outlet	68864	1
3	ROPE - starter	55898	1	47	TANK - fuel	88172-A1	1
4	GRIP - rope	56997	1	48	DECAL - caution	04134	1
5	INSERT - rope retaining	58817	1	49	CAP - tank	A-85741	1
6	SPRING - rewind	58451-1	1	50	Includes: VALVE - relief	58805-1	1
7	PULLEY - starter	58452	1	50A	GASKET - fuel filter cap	58807	1
8	WASHER - brake	58870	2	51	SCREW - rd hd., #6 x 1/2	80619	16
9	FRICITION SHOE ASSEMBLY	A-57647	1	52	COVER - tank	88173-1	1
10	SPRING - brake	58455	1		GASKET - fuel tank cover		
11	WASHER - brake retainer	78456	1		(optional - not shown)	88887	1
12	RING - retaining	80818	1	53	LINE - oil (flexible)	58805	1
13	CUP - starter	58820-1	1	54	FILTER ASSEMBLY	A-59251	1
14	SCREEN - rotary	68294	1	55	Includes: FILTER	60213-1	1
15	HOUSING - fan	59094-1	1	56	RING - retaining	58219-A	1
16	WASHER - flat, 7/16	84047	1	57	BEARING - ball	58110-B	1
17	NUT - hex hd., 7/16-20	81104	1	58	WASHER - lock	88001	2
18	ROTOR	57888-B	1	59	SCREW - bearing retainer	10838-B	2
19	CLAMP - dust cover	65890	1	60	CRANKSHAFT	68810-3	1
20	COVER - dust	58878	1	61	ROLLER - set of 27	A-68618	1
21	GASKET - dust cover	68978-2	1	62	GASKET - crankcase	88360	1
22	SCREW GROUP - condenser	57760	1	63	ROD - connecting	A-68483	1
23	SCREW - flt hd., 10-24 x 1/8	80880	2	64	Includes: SCREW	80805	2
24	WASHER - lock, #10	89048	2	65	BEARING - needle	69351	1
25	CONDENSER - w/terminal	58897	1	66	PETROL & TIN	A-68828-B	1
26	SCREW - flt hd., 10-24 x 1/2	80696	1	67	Includes: RING - retaining	55095	1
27	SCREW GROUP - point	57749	1	68	RING - retaining	84742	1
28	BLEAKER POINTS (set)	A-58188	1	69	RING - piston	55038	2
29	Includes: WICK - felt	58984	1	70	EXCHANGER - heat (optional)	59279	1
30	NUT - terminal	58982	1	71	SCREW - hex hd., 12-24 x 3/8 (optional)	80857	2
31	TAB - ground	87793	1	72	CAP - muffler (optional)	58425-A	1
32	WASHER - terminal	58983	1	73	STUD - muffler (optional)	68837	2
33	KEY - rotor	75078	1	74	BAFFLE - muffler (optional)	68423-A	1
34	WASHER - sealing mounting	58828-A	1	75	BODY - muffler (optional)	A-88419	1
35	LEAD - ground w/terminal	A-58821	1	76	MUFFLER	88419-1	1
36	BOX - breaker w/cors	57744	1	77	DEFLECTOR - air (optional)	88689	1
37	COIL - w/ground terminal	58886-A	1	78	SPARK PLUG	40190-B	1
38	LEAD - high location	68882	1	79	Includes: GASKET	25038	1
39	SCREW - hex hd., 10-24 x 3/8	80888-1	3	80	CYLINDER - 2" bore	58174-2	1
40	CLAMP - lead	56014	1	81	NUT - hex, 1/4-28	81068-B	4
41	GROMMET	60929	1	82	WASHER - lock, 1/4	85008	4
42	TERMINAL - spark plug	A-68878-A	1	83	GASKET - cylinder	68292	1
43	CRANKCASE	A-58317-B1	1	84	SLEEVE	58880	1
				85	SHIELD - cylinder	A-68818-1	1

*Denotes new part.

Ⓢ When HEAT EXCHANGER is installed, remove AIR DEFLECTOR.

SPECIAL TOOLS available on order

A-68993	COMBINATION WRENCH	33883	SLEEVE - shaft (drive case)
A-68999	PLUG - needle bearing (perm. rod)	23878	PLUG - bearing
23828	WRENCH - socket borew (perm. rod)	23138	TOOL - clutch drum bearing
23886	PLIERS - snap ring (pinion)	A-23888	REMOVER - spider, pin gear
A-23860	REMOVER - rotor	23878	TOOL - starter bearing
23138	BODY - assembly	A-68878	REMOVER - starter bearing
82480-2	ADAPTER - main bearing	-	BRADING PULLER - clutch drum
A-68672	JACKSCREW	A-23861	(#4-78 Snap-On or equivalent)
23870	PLATE - shaft aligning		PLUG - Piston Pin
23833-1	PLUG - seal assembly		
88871	PLUG - drive case seal		
		PART	
		23318	SPRAY CAN - blue

REPLACEMENT DECAL #23742 composed of "DIRECT DRIVE", "GEAR DRIVE", "STARTING INSTRUCTIONS" and two "HOMELITE" (letters 1/2" and 1/4" high).

HOMELITE C-52 CHAIN SAW

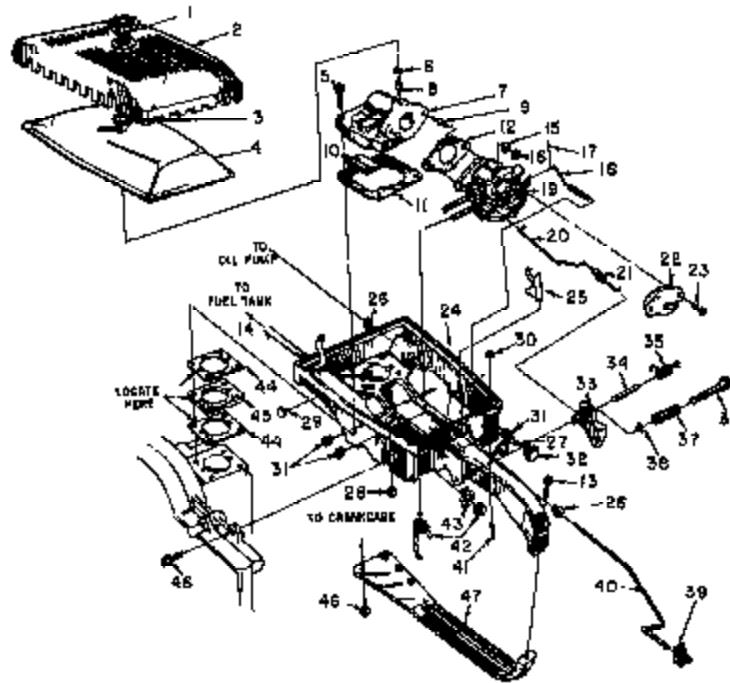

FIGURE 3

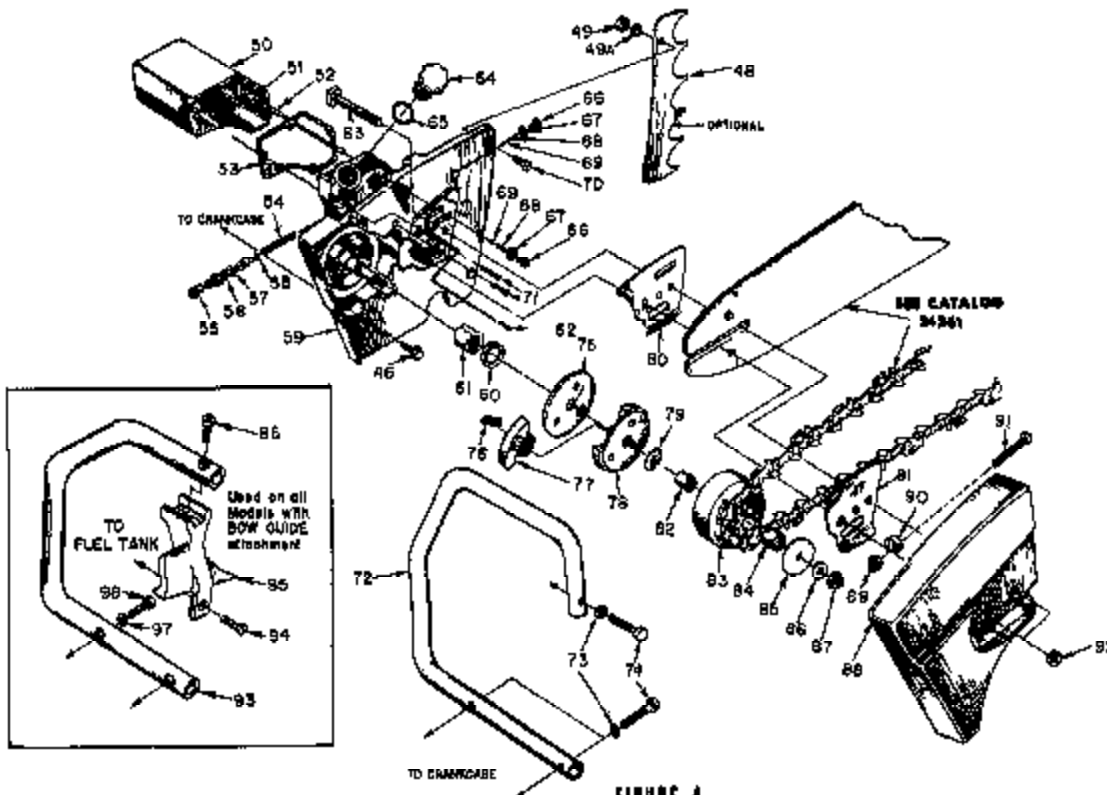

FIGURE 4

HOMELITE C-52 CHAIN SAW

No.	Description	Part No.	Qty.	No.	Description	Part No.	Qty.
1	NUT - cover	A-59220	1	58	GASKET - reservoir	58342	1
2	COVER - air filter	59230-1	1	54	SPRING - plunger	59298	1
3	RING - retaining	58318-A	1	55	CONNECTOR - oil pump	58327-A	1
4	ELEMENT - air filter	59225	1	56	PLUNGER - oil pump	A-59834-10	1
5	SCREW - hex hd., 12-24 x 1 1/2	50855	4	57	Includes: "O" RING	59074	1
6	GASKET - stud	58392	1	58	"O" RING	74388	1
7	ELBOW - reed	A-59490	1	59	DRIVECASE	A-58493-A1	1
8	Includes: STUD - cover	58381	1	60	Includes: SEAL	58258-A	1
9	STUD - carburetor	57404	2	61	BEARING - needle	58043	1
10	FILLER BLOCK	58933	1	62	PLUG	59821	1
11	GASKET - elbow	58344	1	63	BOLT - guide bar TUBE - oil line (not shown)	58334 59029	2 1
12	GASKET - carburetor	55553-B	1	64	CAP - oil filler ① w/Bow Guide (optional)	A-64310	1
13	SCREW - hex hd., 12-24 x 1	50884	1	65	Includes: GASKET	A-56580-1	1
14	LINE - fuel	55590	1	66	VALVE - vent (not shown)	58807	1
15	WASHER - lock, 1/4	59009	2	68	CAP - check valve	58339	2
16	NUT - hex, 1/4-20	51013-3	2	67	GASKET	58336	2
17	COTTER PIN - 1/32 x 1/2	58924	1	69	SPRING - check valve	51022	2
18	ROD - choke	A-58354	1	69	BALL - check	25527	2
19	CARBURETOR	A-58427-A	1	70	SCREW - flat hd., 1/4-20 x 3/4 Included in index #48	50053	2
20	ROD - throttle	58398	1	71	SCREW - rd hd., 5 x 3/4	50790	5
21	BOOT - rod	58948	1	72	HANDLE BAR - flush cut Optional wrap around flush cut (reversible bow only)	A-58379-B A-58398 A-64727	1 1 1
22	DEFLECTOR - carburetor (optional)	58897-2	1	73	WASHER - lock, 5/16	50003	3
23	SCREW - pan hd., 10-32 x 1/2 (optional)	50625	2	74	SCREW - hex hd., 5/16-18 x 1 1/2	50087	3
24	HANDLE - throttle	A-58398	1	75	COVER - clutch	53051	1
25	Includes: STOP - reed	58930	1	76	SPRING - clutch	55842	3
26	BUSHING - rod	58929	2	77	SHOE - clutch	54589	3
27	BUSHING - lock pin	59064	1	78	PLATE - clutch	58055-1	1
28	PLUG - button Includes: "O" RING	A-58474 59765	1 1	79	WASHER - thrust (inner)	58835	1
29	PLUG - button	54507	1	80	PLATE - guide bar (inner)	58871-A	1
30	WASHER - felt	59290	1	81	PLATE - guide bar (outer)	58372-B	1
31	BUSHING	58382	3	82	RACE - inner	55684	1
32	BUTTON - rod	57288-1	1	83	SPROCKET & DRUM ② Open Type - .404" pitch, 7 tooth ③ Optional - 3/8" pitch, 7 tooth ③ 3/8" pitch, 8 tooth	A-59555 A-59552 A-58349	1 1 1
33	TRIGGER - throttle	58181-A	1	84	Includes: BEARING - needle (Optional - not shown)	72311	1
34	SHAFT - trigger	58553	1	DRUM & HUB - "splined" type sprocket Includes: BEARING - needle	OM-10615 55804	1 1	
35	SPRING - throttle	58352-A	1	SPROCKET - splined	OM-68810	1	
36	PIN - throttle lock	58404	1	RIM TYPE - 3/8" pitch, 7 tooth .404" pitch, 7 tooth	OM-10613	1	
37	SPRING - lock	58405	1	85	WASHER - thrust (outer)	55183-1	1
38	RING - retaining	58408	1	86	WASHER - flat, 3/8	54010-1	1
39	BUTTON - oil rod	58357	1	87	NUT - hex, 3/8-24	51182	1
40	ROD - oil pump	58358-B	1	88	COVER - drivecase	A-58378-1	1
41	COTTER PIN - 1/16 x 1/2	58301	1	89	Includes: NUT - 5/16-18	51182	1
42	SWITCH - toggle w/nut	A-57450-3	1	90	PIN - adjusting	58613-1	1
43	PLATE - "On - Off"	72085-A	1	91	SCREW - pin	50617	1
44	GASKET - spacer	58342	2	92	NUT - hex, 3/8-16 Required with BOW GUIDE	51089-2	2
45	SPACER	58391	1	93	HANDLE BAR - flush cut	A-58713	1
46	SCREW - hex hd., 12-24 x 3/4	50887	3	94	SCREW - socket, 5/16-18 x 1/8	50858	1
47	BRACE - throttle handle	58186-A1	1	95	BRACKET - handle	58885-2	1
48	KIT - spiked bumper (optional)	A-58049	1	96	SCREW - socket, 5/16-18 x 1	50308	1
49	Includes: NUT - hex hd., 1/4-20 (optional)	51063	2	97	WASHER - lock, 5/16	53003	2
49A	WASHER - lock, 1/4 (optional)	53009	2	98	SCREW - hex, 5/16-18 x 1 1/2	50087	2
50	RESERVOIR - oil Includes: COTTER PIN (not shown)	A-58341 58301	1 1	98	GUARD - chain (not shown)	58584	1
51	FILTER - oil	A-58228	1				
52	LINE - oil filter	58340-B	1				

① BOW GUIDE requires A-56580-1 CAP.

② Check type and number of teeth on sprocket before ordering.

③ Use 55183-1 WASHER with .404 pitch -- use 58228 WASHER with 3/8 pitch.



HOMELITE

A **Dynalene** DIVISION • PORT CHESTER, NEW YORK

