

ILLUSTRATED PARTS LIST

PART NO. 17151
Printed in U.S.A.
Price .35¢



**HOMELITE®
550 SERIES
PROFESSIONAL
CHAIN SAWS**

**MODELS
550
550W
550SL**

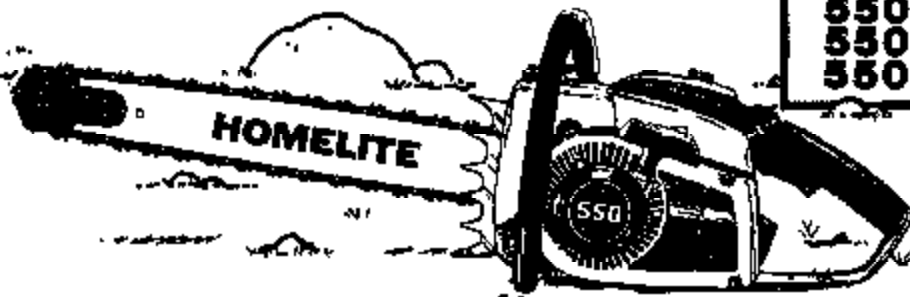

- UT10458
- UT10497
- UT10498
- UT10636

HOMELITE TEXTRON

Homelite Division of Textron Inc

550
550W
550SL

FIG. 1

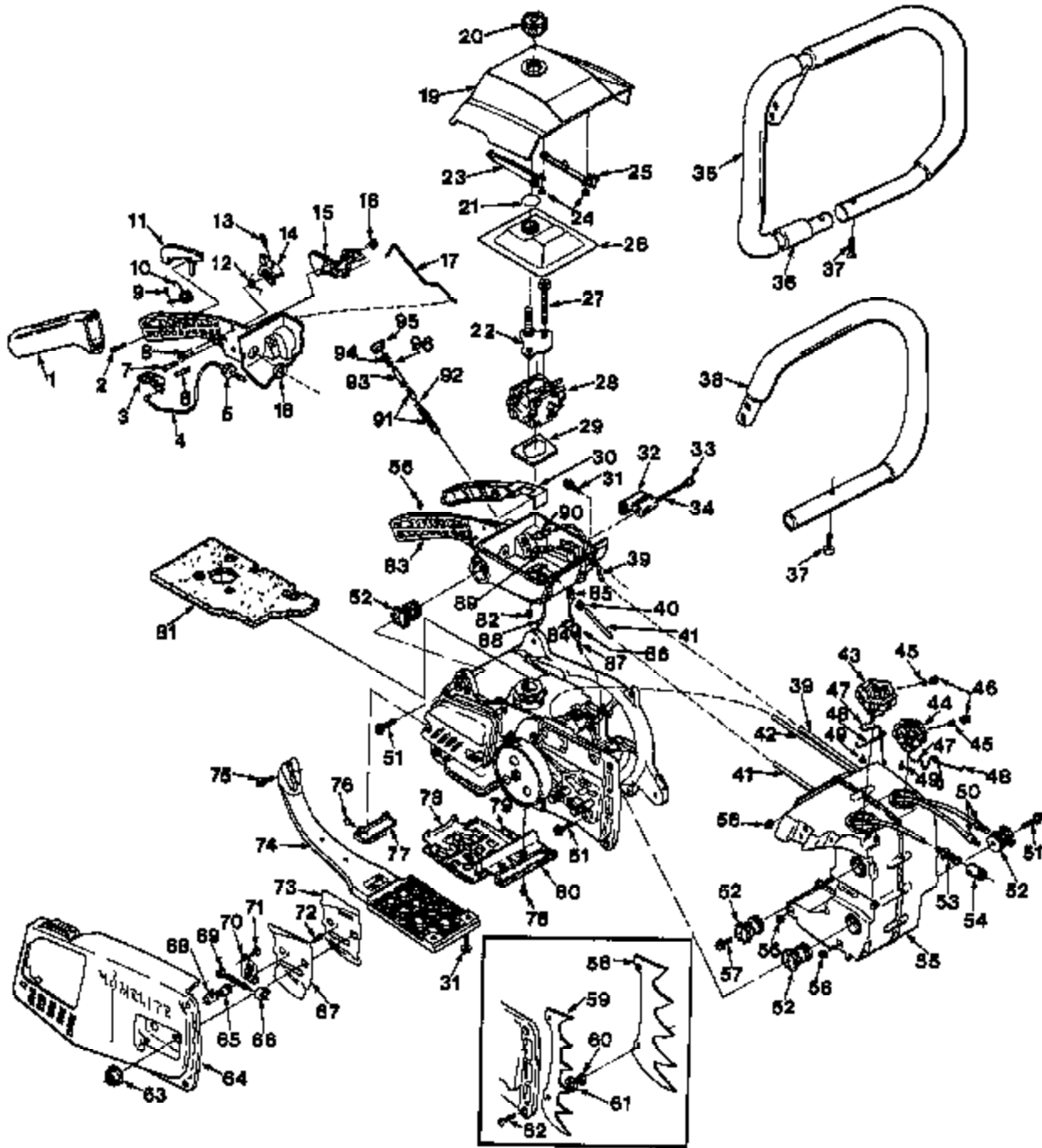

550
550W
550SL

No.	Description	Part No.	Qty.	No.	Description	Part No.	Qty.
1	GRIP	70018-1A	1	52	ISOLATOR- Vibration	A-70421-A	3
2	PIN- Groove	12462	1	53	FILTER- Fuel	A-58251	1
3	LEVER- Choke	12620	1		Includes:		
4	ROD- Choke	12349	1	54	FILTER- Felt	58253-1	1
5	BOOT- Choke rod	58848	1	65	TANK- Fuel & Oil	A-12395-3B	1
6	PIN- Groove, choke	12423	1	56	NUT- Hex, 10-24 griploc	81208	9
7	PIN- Trigger	66548	1	57	SCREW- Hex, Sems 10-24 x 1/2"	88049	1
8	PIN- Groove, throttle latch	12481	1	58	PLATE- Spiked bumper (550W)	A-12461-B	1
9	SCREW- Drive	60001	1	59	PLATE- Spiked bumper (550, 550SL)	A-12480-B	1
10	SPRING	12457	1		Items #58 & 59 include:		
11	LOCKOUT	12330	1	60	NUT- Hex 12-24	91068	2
12	SPRING- Torsion, throttle latch	12454	1	61	WASHER- Lock #12	70901	2
13	SCREW- Set (starting speed adj.)	12440	1	62	SCREW- Pan, 12-24 x 1/2"	80963	2
14	LATCH- Throttle	12484-1	1	63	NUT- Hex, flange 3/8-16	12860	2
15	TRIGGER- Throttle	12362	1	64	COVER- Drivecase (550, 550W)	A-12334-1	1
16	SPRING- Throttle trigger	12441	1		NOTE: See Figure 4 for 650SL D'ossa		
17	ROD- Throttle	12350	1		Includes:		
18	BOOT- Throttle rod	67634	1	65	ADJUSTER- Guide bar	A-70694	1
19	COVER- Air filter	A-70067-B	1	66	PIN- Guide bar adjuster	83039	1
	Includes:			67	PLATE- Guide bar (outer)	70400	1
20	NUT- Air filter cover	A-87838-2	1	68	BUSHING	70699	1
21	RING- Retaining	58319-A	1	69	SCREW- Adjuster	A-12746	1
22	BRACKET- Cover mounting	A-93287	1	70	COVER- Gear	12134	1
23	INSERT- Air filter cover (solid)	12493	1	71	SCREW- Pan, 6-32 x 3/8"	80571	2
24	SCREW- Pan, 8-32 x 1/4"	60575	2	72	SCREW- Truss hd. 8-32 x 3/8"	80548	1
25	INSERT- Air Inlet (notched)	12990	1	73	PLATE- Guide bar (inner)	70399	1
26	FILTER ELEMENT- Air	94108	1	74	BRACE- Throttle handle	12346-2A	1
27	SCREW- Hex, Sems, 10-24 x 2 21/64"	70027	2	75	SCREW- Hex, Sems, 10-24 x 7/8"	88052	1
28	CARBURETOR (SDC-89A)	A-93954-B	1	76	SCREW- Hex, Sems, 8-32 x 3/8"	88041	4
29	SPACER- Carburetor	12340	1	77	SNUBBER- Rear	A-12803-A	1
30	COVER- Throttle handle	12361	1	78	SHIELD- Muffler	A-70255	1
31	SCREW- Hex, Sems 10-24 x 5/8"	88050	6		Includes:		
32	GROMMET- Carburetor adjustment	88186	1	79	SEAL	70377	1
33	SCREW- Idle speed adjustment	12783	1	80	CUSHION	70378	1
34	SPRING- Idle speed screw	12784	1	81	HEAT ISOLATOR	94566	1
35	HANDLE BAR- Full wrap-around (550W)	A-93939	1	82	BUMPER	12096	2
	Includes:			83	HANDLE- Throttle	A-70063-C	1
36	BUSHING	88187	1		Includes:		
37	SCREW- Soc hd. 10-24 x 1"	82246	4	84	LINE- Oil	A-70257	1
38	HANDLE BAR- Flush-cut (550, 550SL)	A-94077	1		Includes:		
39	TUBING- 11 1/4" (manual oiler pick-up)	93112-45	1	85	GROMMET	63312-1	1
40	GROMMET- Fuel line	88048	1	86	NUT	25302	1
41	TUBING- (fuel pick-up) 10 1/2"	94772-42	1	87	SLEEVE	26301	2
42	TUBING- 10 1/4" (auto. oiler pick-up)	93112-41	1	88	LINE- Pulse 3 1/4"	93167-13	1
43	CAP- Fuel filler (with 59501 Gasket)	A-69500-A	1	89	VALVE- Outlet check	A-85077	1
44	CAP- Oil Filler (with 12126 Gasket)	A-12222	1	90	VALVE- Inlet check	A-12987	1
	Items #43 & 44 include:			91	PLUNGER- Manual oil pump	A-67235-A	1
45	VALVE- Check (duck bill)	89461	1		Includes:		
46	FILTER- Porous metal	89454	1	92	"O" RING	58408	1
47	CHAIN- Bead	88602	1	93	ROD- Plunger	A-94094	1
48	RETAINER	88603	1		Includes:		
49	SCREW- Pan hd. 8 x 1/4"	82256	1	94	NUT- Plunger	85082	1
50	FILTER- Oil	A-64293	2	95	BUTTON- Manual oiler	85084	1
51	SCREW- Hex, Sems 10-24 x 3/4"	88061	4	96	"O" RING	59074	1

**550
550W
550SL**

FIG. 2

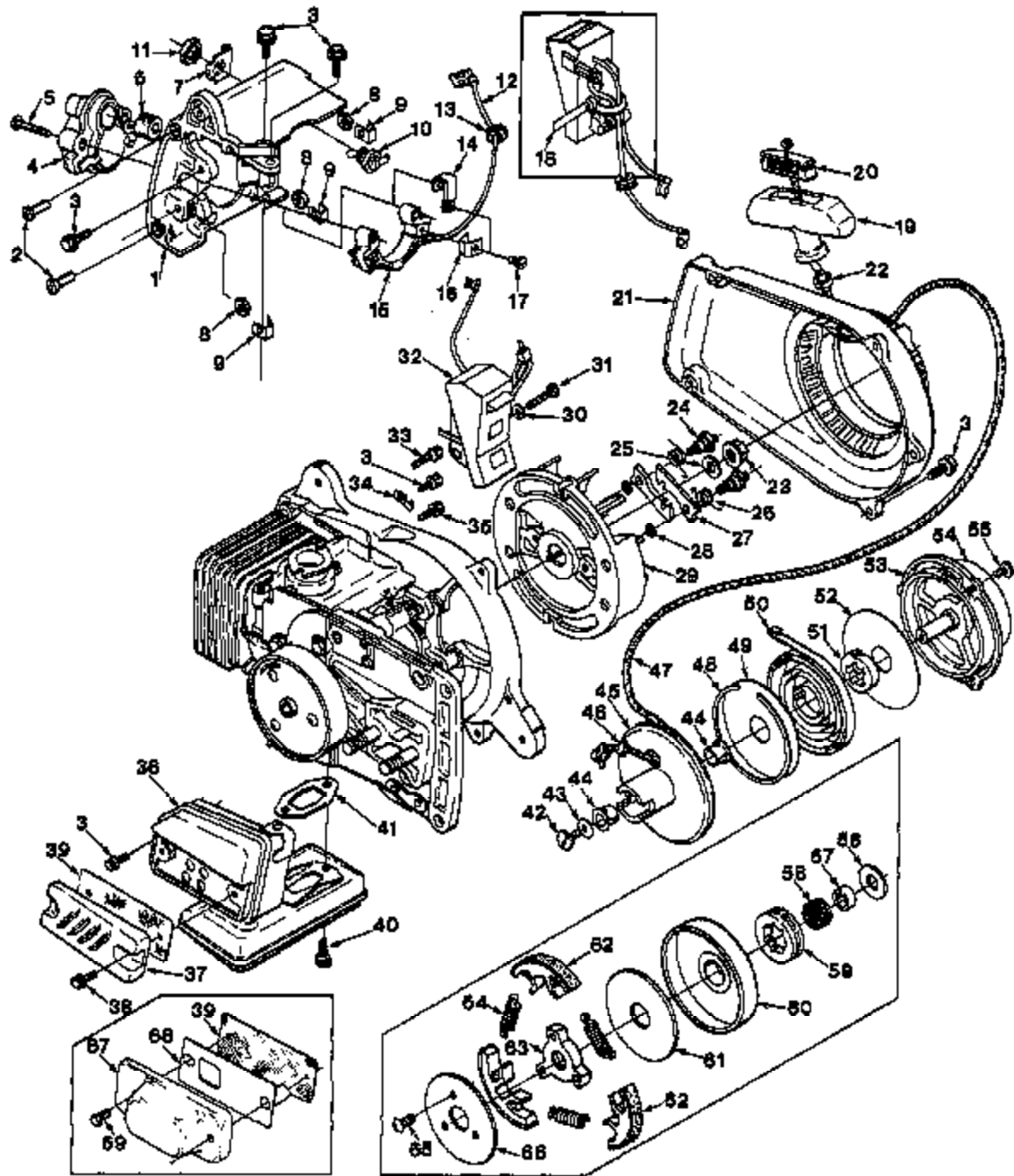

550
550W
550SL

No.	Description	Part No.	Qty.
1	SHIELD- Cylinder Includes:	A-12406-A	1
2	BUSHING- Nylon	12893	2
3	SCREW- Hex Sems 10-24 x 5/8"	88050	10
4	TRANSFORMER Includes:	A-12299-A	1
5	SCREW- Hex washer hd.	70088	2
6	GROMMET	12191	1
7	PLATE- Indicating	12793-A	1
8	NUT- Hex centerlock 10-24	81208	3
9	RETAINER- Nut	12888	3
10	SWITCH- Toggle Includes:	A-12449	1
11	NUT- Hex	72084-A1	1
12	LEAD- Module	A-12719	1
13	GROMMET	88279	1
14	CONTACT- Ground	70720	1
15	RECEPTACLE- Transformer	A-70088	1
16	CONTACT- Transformer	12788	2
17	SCREW- Pan hd., plastite #6 x 3/8"	82216	2
18	TIE- Cables	12288	1
19	GRIP- Starting rope Includes:	A-89982-A	1
20	INSERT- Rope retaining	70018-A	1
21	HOUSING- Starter Includes:	A-12960	1
22	BUSHING- Starter Rope	87177	1
23	NUT- 3/8-24	81233	1
24	STUD- Shoulder	83079	2
25	WASHER- Flat 3/8" I.D.	84089	1
26	SPRING- Starter pawl	85376	2
27	PAWL- Starter	84442-B	2
28	WASHER- Lock starter pawl	83056	2
29	ROTOR	70924	1
30	WASHER- Flat #8	84101	2
31	SCREW- Hex Sems 8-32 x 1.25"	88048	2
32	MODULE & CORE	12888-A	1
33	SCREW- Hex Sems 10-24 x 7/8"	88062	1
34	CLIP- Wire	12886	1
35	SCREW- Hex Sems 10-24 x 3/4"	88051	1
36	MUFFLER	A-12411-1D	1
37	CAP- Muffler exhaust	12388-1	1

No.	Description	Part No.	Qty.
38	SCREW- Hex Sems 8-32 x 3/8"	88041	2
39	ARRESTOR- Spark (STD on 550W only)	A-83897-A	1
40	SCREW- Cap hex soc 1/4-20 x 5/8"	82302	2
41	GASKET- Muffler	84780	1
42	SCREW- Pan 10-24 x 1/2"	82216	1
43	WASHER- Retaining	12788	1
44	BUSHING- Starter post	12639	2
45	PULLEY- Starter Includes:	A-70199	1
46	WASHER- Nylon	83882	1
47	ROPE- Starter	A-93875	1
48	RING- Shield retaining	83876	1
49	SHIELD- Spring (inner)	12321-B	1
50	SPRING- Rewind	12324	1
51	LOCK- Rewind spring	12455	1
52	SHIELD- Spring (outer)	12320-A	1
53	COVER- Starter housing	A-70726-1	1
54	DECAL- 660	88085	1
55	SCREW- Pan hd. 8-32 x 1/2"	82254	3
56	WASHER- Thrust (inner) (for rim sprocket only)	83482	1
57	RACE- Inner	84128-A	1
58	BEARING- Roller	84124	1
59	SPROCKET- 7 spline 7T - 3/8" pitch	83284	1
60	DRUM & HUB	A-84117	1
61	WASHER- Thrust	83850	1
62	SHOE- Clutch	A-84126	3
63	SPIDER- Clutch	83811	1
64	SPRING- Clutch	83814-A	3
65	SCREW- Torx SCREW- Mech. pan hd. 8-32 x 3/8" (alternate)	83128	3
66	COVER- Clutch	83628	1
67	CAP- Muffler (downdraft) (accessory) Includes:	A-70036	1
68	PLATE- Baffle	12460	1
69	SCREW- Hex Sems 8-32 x 5/8	88043	2

ACCESSORIES

SPROCKET & DRUM (7T-3/8" pitch)	A-84116
WASHER- Thrust (spur sprocket only)	83483

**550
550W
550SL**

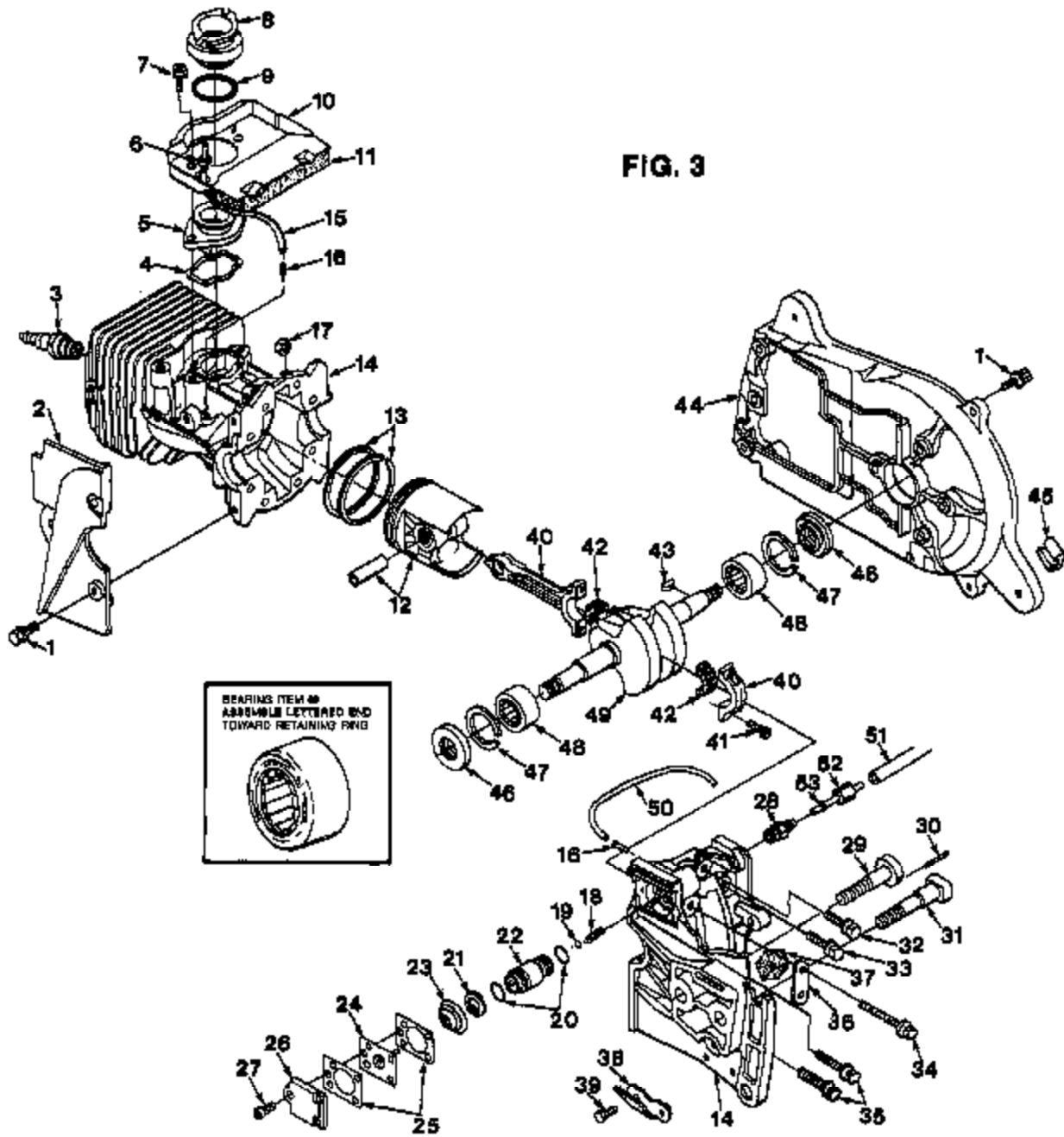

550
550W
550SL

No.	Description	Part No.	Qty.
1	SCREW- Hex, Sems 10-24 x 5/8"	88050	7
2	SHIELD- Sawdust	12338-2	1
3	SPARKPLUG DJ-6J	86130-S	1
	SPARKPLUG CJ4 (optional)	89027-S	1
4	GASKET- Intake manifold	12314-B	1
5	MANIFOLD- Intake	12313	1
6	GROMMET	84652	1
7	SCREW- Hex Sems 10-24 x 1/2"	88049	2
8	CONNECTOR- Carburetor	12948-A	1
9	SPRING- Garter	12406	1
10	DEFLECTOR- Air	A-70379	1
	Includes		
11	SEAL	70377	1
12	PISTON & PIN	A-83695	1
	Includes		
13	PISTON RING	12911	2
14	CRANKCASE & CYLINDER	A-70858-1B	1
	Includes		
15	LINE- Pulse (3 25 long)	89167-13	1
16	FITTING- Tube	89833	2
17	NUT- Hex, 10-24 Gripco	81208	8
18	SPRING- Check valve	88670	1
19	BALL- Check valve	80051	1
20	"O" RING	74388	2
21	RING- Retaining	12996	1
22	BODY- Automatic oil pump	A-94236	1
23	SPRING- Oil pump	84834	1
24	PLUNGER- Oil pump	A-12358-B	1
25	GASKET	89244-1	2
26	COVER- Oil pump	88224-2C	1
27	SCREW- Pan hd 8-32 x 3/8	80571	3
28	FITTING- Straight	31733-1	1
29	BOLT- Guide bar	70958	1
30	PIN- Dowel	68761	1
31	BOLT- Guide bar	12397	1
32	SCREW- Hex Sems 10-24 x 1 1/4"	88054	1
33	SCREW- Hex Sems 10-24 x 1 3/8"	88055	4
34	SCREW- Hex Sems 10-24 x 2"	88057	1
35	SCREW- Hex SEMS 10-24 x 1"	88053	2
	GASKET- Muffler (Not shown)	84750	1
36	CLAMP	70816	1
37	FILTER (to cover pump vent hole)	70984	1
38	STOP- Chain	70705	1
39	SCREW- Hex Sems 8-32 x 1/2"	88042	2
40	ROD- Connecting	A-70300-1B	1
	Includes		
41	SCREW- Soc, hd cap	88918	2
42	BEARING- Caged	A-70793	1
43	KEY- Woodruff	75078	1
44	PLATE- Back	A-12938-C	1
	Includes		
45	SNUBBER	12828	1
46	SEAL- Main	12806	2
47	RING- Retaining	12310	2
48	BEARING- Roller (main)	83185	2
49	CRANKSHAFT	70289-2A	1
50	LINE- Flexible (auto oiler pick-up)	83112-41	1
51	LINE- Oil	A-70267	1
	Includes		
52	NUT- Compression	25302	2
53	SLEEVE- Compression	25301	1
	GROMMET (Not shown)	53312-1	1

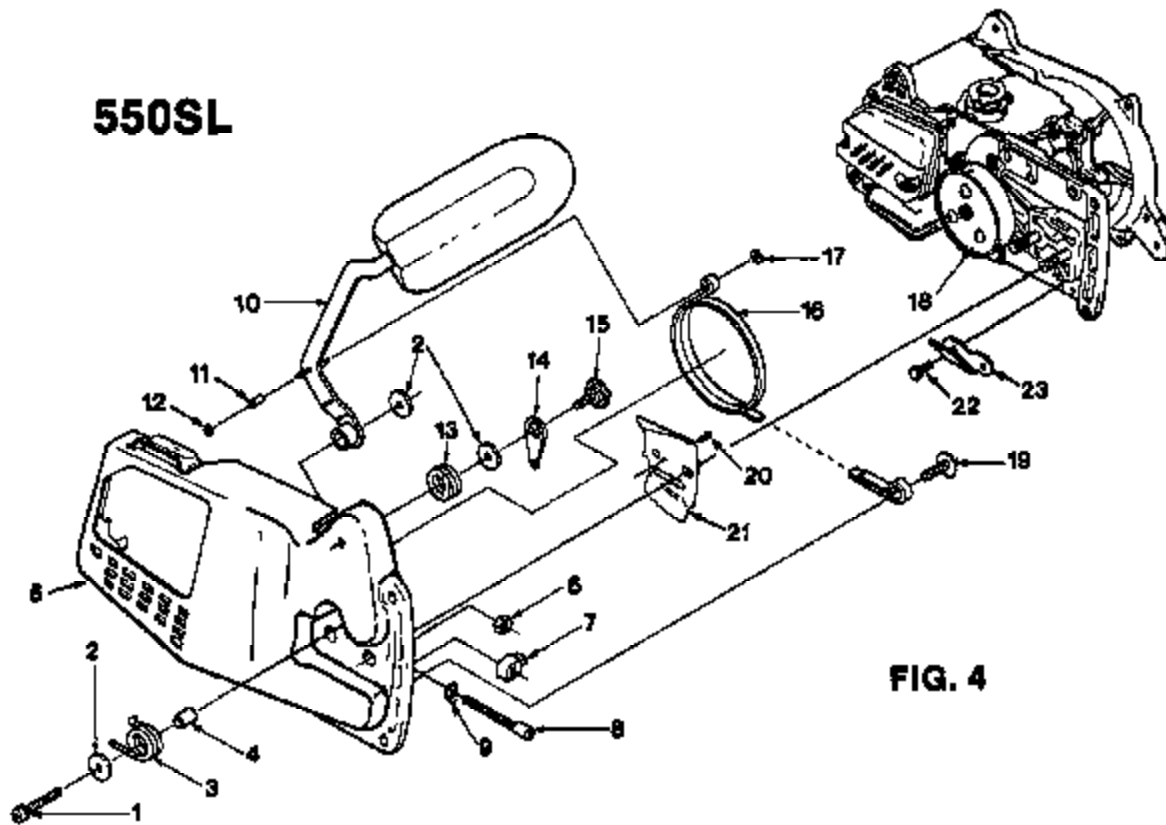

No.	Description	Part No.	Qty.
	KIT- Chain brake	A-93916	1
	Includes		
1	SCREW- Soc cap hd	80426-1	1
2	WASHER	93282	3
3	SPRING- Brake lever	93603	1
4	SLEEVE- Lever	93296	1
5	COVER- Drivecase	A-93869-A	1
	Includes		
6	NUT- Centerlock	81204	1
7	PIN- Guide bar adjusting	93038	1
8	SCREW- Guide bar adjusting	94683	1
9	O RING*	59074	1
10	LEVER- Brake w/guard	A-93775-A	1
	Includes:		
11	BEARING- Roller	93825	1
12	"E" RING	70825	1
13	SPRING- Locking lever	93800	1
14	LEVER- Locking	93602	1
15	SCREW- Shoulder	93778	1
16	BRAKE BAND	A-94660	1
	Includes		
17	"E" RING	69599	1
18	DRUM & HUB	A-94117-2	1
19	SCREW- Pan hd 1/4-20 x 5/8	82258	1
20	SCREW- Truss hd 6-32 x 3/8	80548	1
21	PLATE- Guide bar	70400	1
22	SCREW- Hex hd Boms 8-32 x 1/2"	66042	2
23	STOP- Chain	70705	1

**550
550W**

No.	Description	Part No.	Qty.
1	KIT- Hand guard Includes	A-93869	1
2	WASHER- Flat	94887	1
3	SCREW- Shoulder	93814	1
4	WASHER- Belleville	70788	1

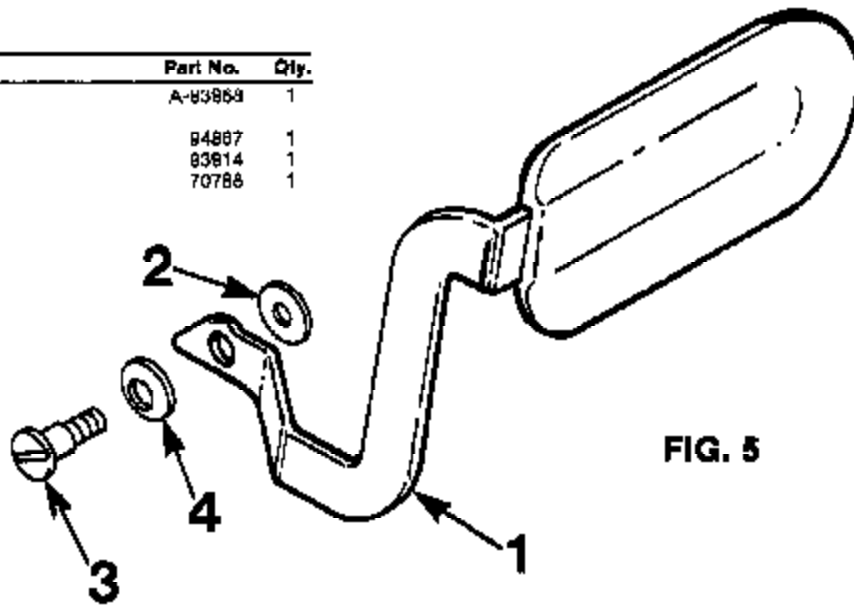

FIG. 5

NOT SHOWN

KIT- Hand guard (right)	A-12267-A	1
Includes		
SCREW- Hex soc , 10-24 x 3/8	82275	2
NUT- Centerlock	81208	2
WASHER	84003-1	2

EXCHANGER- Heat (accessory)

A-94983	1	
Includes		
INSERT- Air filter cover	12990	1
SCREW- Hex Sems-32 x 1/2"	88042	4
NUT- Hex, centerlock 8-32	81223	2

NOTE Heat Exchanger will not be available until Fall 1979

550
550W
550SL

A-93964-B
SDC-69A

FIG. 8

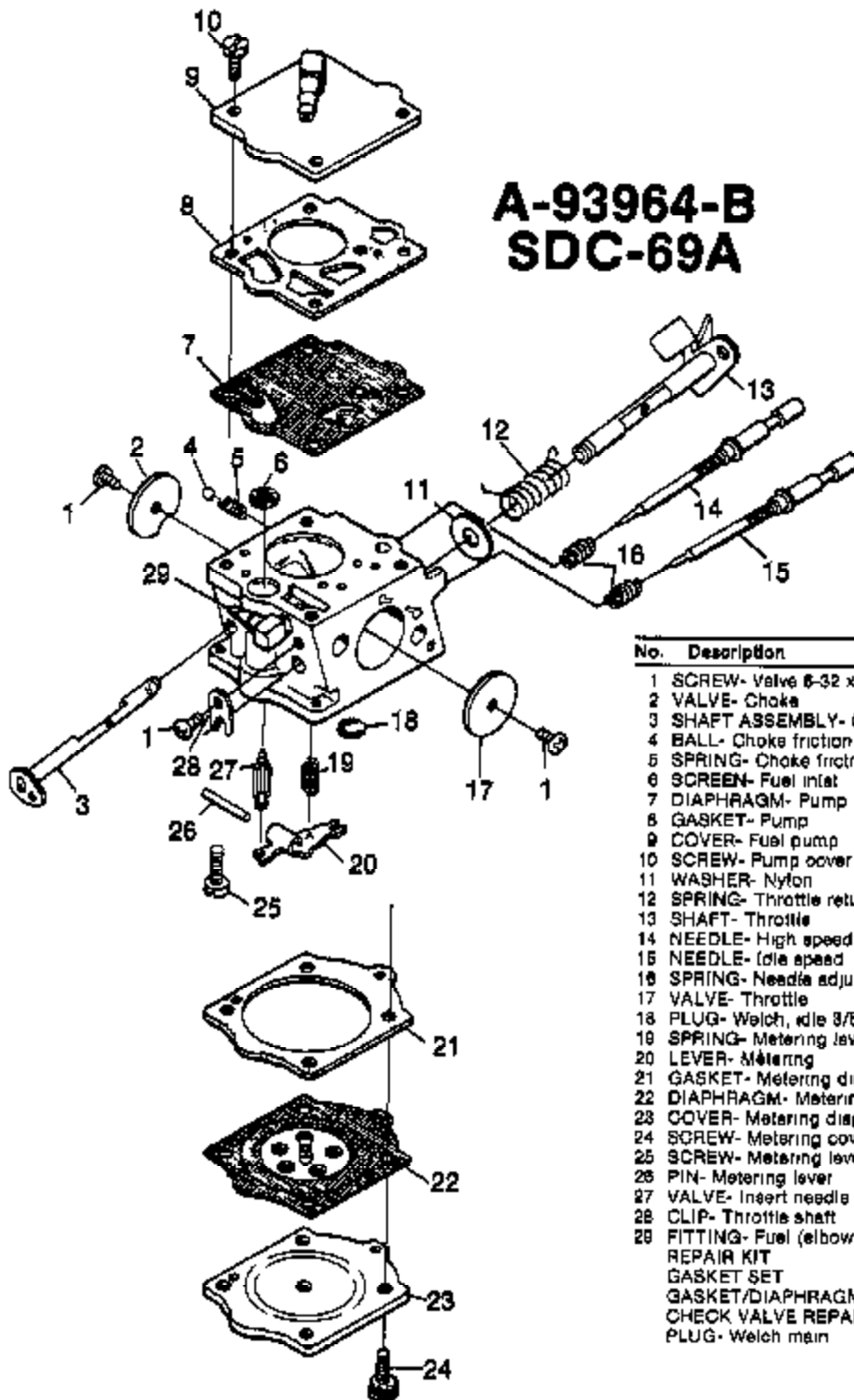

No.	Description	Part No.	Qty.
1	SCREW- Valve 8-32 x 3/16"	* 64693	3
2	VALVE- Choke	12921-A	1
3	SHAFT ASSEMBLY- Choke	12920-A	1
4	BALL- Choke friction	* 60061	2
5	SPRING- Choke friction	* 64238	2
6	SCREEN- Fuel inlet	* 64243	1
7	DIAPHRAGM- Pump	+ 64233	1
8	GASKET- Pump	+ 67008	1
9	COVER- Fuel pump	70040	1
10	SCREW- Pump cover	64694	4
11	WASHER- Nylon	70734	1
12	SPRING- Throttle return	* 67006	1
13	SHAFT- Throttle	70823	1
14	NEEDLE- High speed	* 70794	1
15	NEEDLE- Idle speed	* 12923-A	1
16	SPRING- Needle adjustment	* 64236	2
17	VALVE- Throttle	12919	1
18	PLUG- Welch, idle 3/8"	* 30618	1
19	SPRING- Metering lever	* 64123	1
20	LEVER- Metering	* 64245	1
21	GASKET- Metering diaphragm	+ 64231	1
22	DIAPHRAGM- Metering	+ 64235	1
23	COVER- Metering diaphragm	64224	1
24	SCREW- Metering cover	64689	4
25	SCREW- Metering lever pin	* 64688	1
26	PIN- Metering lever	* 64244	1
27	VALVE- Insert needle	* 64229	1
28	CLIP- Throttle shaft	74961	1
29	FITTING- Fuel (elbow)	65365	1
	REPAIR KIT	64276	1
	GASKET SET	67019	1
	GASKET/DIAPHRAGM KIT	* 70811	1
	CHECK VALVE REPAIR KIT	63910	1
	PLUG- Welch main	* 65482	1

* indicates contents of Repair Kit

+ indicates contents of Gasket/Diaphragm Kit

**550
550W
550SL**

ACCESSORIES AND TOOLS

ACCESSORIES

Compound (DC4) Silicone Grease for transformer spring	22636-A
Adhesive (14 gram tube) cylinder shield bushing and bumper in back plate	70827
Starter Rope- 250 ft. reel -#5	57084-1
Tubing, Rubber- 10 ft. -fuel & oil	93112-99
Tubing, Rubber- 10 ft. -pulse line	93157-99
Tubing, Rubber- 10 ft. -fuel pick-up	94772-99
Sprocket & Drum (SL units only) (Spur type)	A-94116-2
Silastic- for cylinder flange, muffler gasket and muffler screws.	24823

TOOLS

Bit, Torx- (drive with 1/4" socket-clutch plate screws)	17115-01
Bit, Torx- (drive with 5/16" socket-clutch plate screws)	17115-02
C.D. Test Lamp-Ignition check	A-24994
Key, Hex- Connecting Rod	23528
Puller, Rotor	A-24290
Screwdriver (550/550SL) use to drive 68651 wrench	24541
Shim- Yellow .020 -Rotor Air Gap	24853
Sleeve- Seal -crankshaft assembly	23759
Tool & Plunger -Piston Pin assembly and removal	A-24671
Tool, Clutch Removal --3 shoe lined	A-17146
Wrench, Combination (550W) -Guide bar nuts	A-24284
Wrench, Socket -Spark plug	68651
Key, Hex 3/16" for muffler screws-use with 68651 wrench	94624
Wrench, Combination (will supersede 94624 in Fall 1979)	17302

19/324

HOMELITE **TEXTRON**

Homelite Division of Textron Inc.